

DICENTIS

Conference System

Table of contents

1	Safety	7
2	About this manual	8
2.1	Intended audience	8
2.2	How to use this manual	8
2.3	Copyright and disclaimer	9
2.4	Document history	9
3	System overview	11
3.1	Hardware requirements	14
3.2	Network requirements	19
3.3	Software requirements	19
3.4	License requirements	19
3.4.1	License overview	20
3.5	Security measures	25
3.6	GUI languages	25
4	Software installation	27
4.1	Installing the DICENTIS software suite	27
4.2	Downloading software to the devices	27
4.3	Adding and removing licenses	28
4.3.1	Activation tool description	29
4.3.2	Initial registration of the system	29
4.3.3	Adding/returning licenses	31
4.4	Server console	31
4.5	Rapid Spanning Tree Protocol (RSTP) support	32
4.6	Creating certificates for web-based clients	33
4.7	Installing the Participant Application	34
5	Meeting application	35
5.1	User rights and meeting rights	38
5.2	Manage	40
5.2.1	Meeting	40
5.2.2	Agenda	41
5.2.3	Participants	41
5.2.4	Voting	41
5.2.5	Discussion	43
5.2.6	Menu	44
5.3	Prepare	45
5.3.1	Persons	45
5.3.2	Discussion profiles	48
5.3.3	Meetings	52
5.3.4	Meeting details	53
5.3.5	Participants	55
5.3.6	Agenda	56
5.3.7	Topic details	56
5.3.8	Participant List	56
5.3.9	Speaker waiting list	57
5.3.10	Voting script	57
5.3.11	Voting round details	57
5.3.12	Voting settings	61
5.3.13	Prepare interpretation	61

5.4	Configure	62
5.4.1	User groups	62
5.4.2	Users	62
5.4.3	Languages	63
5.4.4	Rooms	63
5.4.5	Audio settings	65
5.4.6	Audio routing settings	67
5.4.7	Camera Settings	68
5.4.8	Seats and devices	71
5.4.9	Participant Application	75
5.4.10	Language selection	76
5.4.11	Interpreter desks	79
5.4.12	Floor and language routing	85
6	DICENTIS Webserver	91
6.1	First time login	92
6.2	Configuration procedure	93
6.3	Control microphones	94
6.4	Manage speech time	95
6.5	Control voting rounds	96
6.6	Control presentation	97
6.7	Control agenda	98
6.8	Control meetings	98
6.9	Switch between synoptic views	99
6.10	Chat with participants	99
6.11	Setting up automatic login and layout selection for hall displays	100
6.12	Post-meeting tools	101
6.12.1	Access through the Webserver	102
6.12.2	Modifying the XSLT style sheets	103
6.12.3	Adding custom setting to style sheet after a software update	103
6.12.4	Authenticity check	104
7	Configuring DICENTIS for hybrid meetings	106
7.1	System setup	106
7.1.1	Licenses	106
7.1.2	Terms and conditions of use	106
7.1.3	Additional hardware	106
7.1.4	Network requirements	106
7.1.5	Hall display and room cameras	107
7.1.6	Audio setup	107
7.2	Setup of remote participants	107
7.3	Preparing a hybrid meeting	107
7.4	Managing a hybrid meeting	108
7.5	Joining a meeting as a remote participant	109
7.6	Automatic updates	110
8	Configuring the Media Gateway	111
8.1	Components	111
8.2	How to configure	115
9	System extension	116
10	Configuring an IDESK (directly on the device)	119
11	Configuring an external HD-SDI switcher	120

11.1	Hardware and software requirements	120
11.2	Configuration Procedure	120
12	Conference protocol	123
13	System Activation Website	124
13.1	Overview	125
13.2	Manage devices	126
13.3	Manage license	127
13.4	Manage users	127
13.5	Manage dealers	128
14	System server	129
14.1	Creating a backup on the server	131
14.2	Restoring the factory image of the server	131
15	Dante gateway	132
16	Hints and Tips	133
16.1	Changing NetTime options	133
16.2	Configuring secretary's PC for use in other VLAN as DICENTIS server	134
16.3	Disabling control encryption	134
16.4	Create a backup of the database	135
16.5	Restore a database	135
16.6	Updating a database to the current version	135
16.7	Creating a clean database	136
16.8	Deleting a database	136
16.9	Connecting DICENTIS to a (remote) SQL server	136
16.10	Downgrading DICENTIS software to a previous version	138
16.11	Downgrading 4.1 or later DICENTIS software to a 4.0 or earlier version	139
16.12	For DICENTIS Conference System Pre-4.40	140
16.12.1	Initial activation of the system	140
16.12.2	Adding additional fulfillments/licenses	141
16.12.3	Returning and repairing a license	142
16.13	Making a backup of a FNP license file	142
16.14	Installing the image server on a different computer	143
16.15	Recovering devices from fail-safe mode	144
16.16	Replacing a defective device	144
16.17	Uploading and accessing files	144
16.18	Configuring the date and time format of the DICENTIS Multimedia device	146
16.19	Using a fixed IP address for the DICENTIS server in a DICENTIS system with ARNI support	146
16.20	Selecting a network interface to work with DICENTIS	147
16.21	Powering down the server via the power button	147
16.22	Camera and presentation streams	147
16.23	Making a backup and restoring your Synoptic configuration	148
16.24	Configuring Dante™ compatible devices	148
16.25	Setting a PIN code for a Dante™ device	149
16.26	Adding a third-party application to a device	149
16.27	Adding additional keyboards to a device	150
16.28	Keeping third-party android apps on top on the multimedia device when changing agenda items	150
16.29	Creating certificates using the command line tool	151
16.30	Remove unused images	152
16.31	ONVIF Camera discovery	152
16.32	Secure login in the .net API for API applications (including Synoptic)	152

16.33	Renewing the registration of the tablets	153
17	Troubleshooting	154
17.1	Devices LED behavior	154
17.2	Network Docent	156
17.3	Using DeviceBrowser to view connected devices	156
17.4	Dumping logging information to a text file for technical support	157
17.5	Adding and removing languages without interrupting the meeting	157
17.6	Known issues	157
17.6.1	Releasing Dual License	157
17.6.2	Network	158
17.6.3	Software and hardware installation	158
17.6.4	Meeting application and DICENTIS device	158
17.6.5	The Interpreter desk displays the DICENTIS logo	159
17.6.6	Camera control	159
17.6.7	MMD does not show logo and participant image	160
17.7	Customer service	160
18	Support and Academy	161

1 Safety

Prior to installing or operating products, always read the Important Safety Instructions which are available as a separate multilingual document: Important Safety Instructions (Safety_ML). These instructions are supplied together with all equipment that can be connected to the mains supply.

Safety precautions

Some of the DICENTIS Conference System products are designed to be connected to the public mains network.

To avoid any risk of electric shock, all interventions must be carried out with disconnected mains supply.

Interventions with the equipment switched on are authorized only when it is impossible to switch the equipment off. The operation must only be performed by qualified personnel.

Old electrical and electronic equipment



This product and/or battery must be disposed of separately from household waste. Dispose such equipment according to local laws and regulations, to allow their reuse and/or recycling. This will help in conserving resources, and in protecting human health and the environment.

Use latest software

Before operating the device for the first time, make sure that you install the latest applicable release of your software version. For consistent functionality, compatibility, performance, and security, regularly update the software throughout the operational life of the device. Follow the instructions in the product documentation regarding software updates.

The following links provide more information:

- General information: <https://www.boschsecurity.com/xc/en/support/product-security/>
- Security advisories, that is a list of identified vulnerabilities and proposed solutions: <https://www.boschsecurity.com/xc/en/support/product-security/security-advisories.html>

Bosch assumes no liability whatsoever for any damage caused by operating its products with outdated software components.

2 About this manual

The manual provides information on how to configure the DICENTIS Conference System, prepare meetings, and manage prepared meetings in the Meeting application. This manual does not describe the hardware installation and user operating instructions. If required, refer to the DICENTIS Hardware Installation manual and DICENTIS User Operation manual.

This manual is available as a digital document in the Adobe Portable Document Format (PDF).

Refer to the product related information on: www.boschsecurity.com.

2.1 Intended audience

This manual is intended for technicians, system integrators and people who have the authorizations to prepare and/or to manage prepared meetings of a DICENTIS Conference System. Before using this manual you should have completed a training course for the DICENTIS Conference System.

2.2 How to use this manual

Refer to the following chapters during installation and maintenance of your system:

- **Safety** - contains essential safety information, which you should read before installing or operating your system.
- **About this manual** - this section; gives information on the intended audience and explains how to use this manual.
- **System overview** - provides a high-level description of the DICENTIS Conference System. A brief description of the system hardware and software is included, as well as an overview of the software licenses/modules.
- **Software installation** - describes how to initially configure the system by installing the DICENTIS software suite and downloading software to the DICENTIS devices. It also explains the Server software, including the Activation Tool, which is required for registering the system.
- **Meeting application** - describes all menu items of the DICENTIS system software. This section assumes that your DICENTIS system has all of the available licenses.
Note: If the required software licenses are not installed some of the menu items described in this manual may not be present on your system.

When navigating the menu items in the system software, use the small triangle in the left window pane to fully expand all options in the navigation tree. These options are sequentially described in the sub-sections of this chapter.

- **DICENTIS Webserver** - explains how to configure and manage the Synoptic site. This enables a chairperson or clerk to have more control over a meeting by granting or stopping speech via a visual layout of the speakers' room. They can also switch between microphone control, display the voting results in various ways, and access voting and meeting files. This chapter also gives information on the automatically generated XML meeting notes and voting notes files that can be used for making the minutes of the meeting. An explanation for modifying the XSLT style sheet, which allows information to be displayed in the local language, is also included.
- **System extension** - explains the requirements for extending your system, that is, how an ARNI (Audio Routed Network Interface) can be used to add additional DICENTIS devices to the system.

- **Configuring an IDESK (directly on the device)** - explains how to configure the DCNM-IDESEK / DCNM-IDESEKVID on the device itself. This enables you to assign booth and desk numbers, assign available languages, adjust the brightness of the display, select output A - B - C, set the headphones used, set the AV synchronization (DCNM-IDESEKVID only), auto configure desks, and view system information.
- **Configuring an external HD-SDI switcher** - explains how a video switcher can be added to the DICENTIS Conference System for dynamically switching HD-SDI video signals. This enables video signals from a camera to be displayed with low latency on a hall-display.
- **Conference protocol** - provides information about the Conference protocol, a platform-independent protocol, and its requirements for the DICENTIS webserver.
- **System Activation Website** - gives information on the Bosch System Activation Site, which amongst other is used to: activate DICENTIS licenses; view received licenses; and create and maintain users and (sub)dealers.
- **System server** - describes how to connect and configure the DICENTIS System server PC.
- **Dante gateway** - explains how the Dante Gateway interface works and provides information on how to configure its different sides: the OMNEO side and the Dante™ side.
- **Hints and Tips** - provides useful information for upgrading, maintaining and using your system. An overview of the hints and tips is included at the beginning of this chapter.
- **Troubleshooting** - explains where to find Troubleshooting information, and provides a list of known issues and their solutions.

2.3 Copyright and disclaimer

All rights reserved. No part of this document may be reproduced or transmitted in any form by any means, electronic, mechanical, photocopying, recording, or otherwise, without the prior written permission of the publisher. For information on getting permission for reprints and excerpts, contact Bosch Security Systems B.V.

The content and illustrations are subject to change without prior notice.

2.4 Document history

Date	Document version	Reason
2023-05	V4.40	Major update to the Activation Tool and System Activation Website .
2023-07	V5.00	Major update to include the new licensing setup: Upon registration, Premium and Ultimate . Removal of mentions to DCN Next Generation.
2023-08	V5.10	Minor update to the functionalities of the Interpreter Desk .
2024-01	V6.10	Minor updates to the Synoptic microphone control, GUI languages, Voting round details, Meeting details, Audio settings . Major update to the Activation Tool .

Date	Document version	Reason
		Chapters added: Configuring DICENTIS for hybrid meetings and Configuring the Media Gateway .
2024-07	V6.20	Minor update to Meetings . Major update to DICENTIS Webserver .
2024-11	V6.30	Minor updates to System overview , Hardware requirements , Network requirements , License Overview under License requirements , Interpreter desks and Devices LED behavior . Chapters and subchapters added: Installing the Participant Application under Software installation , Participant Application under Meeting Application > Configure , Chat with participants under DICENTIS Webserver and Renewing the registration of the tablets under Hints and Tips .
2025-02	V6.40	Minor updates to Server console and Participant Application .

3 System overview

The DICENTIS Conference System is an IP based conference system which runs on an OMNEO compatible Ethernet network. It is used for distributing and processing audio, video and data signals.

Refer to the latest “Release notes” for important information.

It is advisable to participate in the DICENTIS Conference System training before you install, configure, prepare, and operate a DICENTIS Conference System.

This system overview does not give information on redundant network options. For more information, refer to Redundancy options.

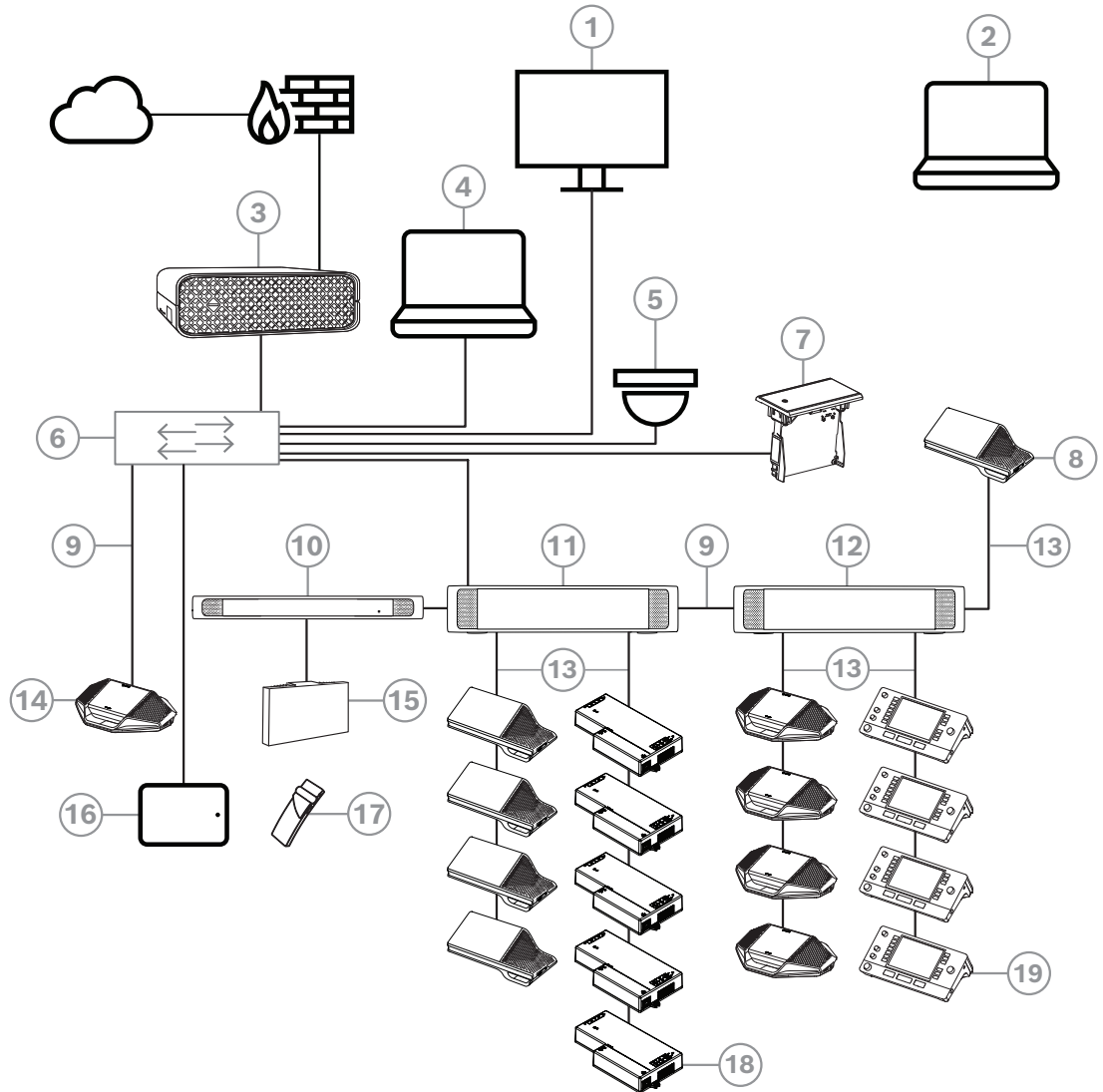

Figure 3.1: Typical DICENTIS Conference System setup

A typical DICENTIS Conference System consists of:

1. Hall display of the conference room:
 - Shows a synoptic layout of the meeting or meeting notes.
2. Laptop:
 - Used by a meeting participant joining remotely.
3. DICENTIS System server:
 - The heart of the system. It licenses functionality, configures and controls the system.
4. Client PC:
 - Can be used to: Manage meetings, prepare meetings and configure the system.

5. Optional video camera (Onvif Profile-S compatible cameras, Sony IP cameras via CGI commands, or Panasonic HD Integrated IP) + external power supply:
 - Captures the image of a speaking participant.
6. Ethernet switch:
 - Ethernet switch with PoE on some ports.
 - Routes de system data via Ethernet.
 - Provides power to the DICENTIS devices via PoE.
7. Flush language selector:
 - This device allows the participants to easily choose their preferred language.
8. Multimedia device:
 - This device is used for “system power on/off”. It is always connected to the powered socket of the Audio processor and powering switch or Powering switch.
Note: Only one DICENTIS Multimedia device should be connected here.
9. CAT-5e Ethernet cable (minimum requirement).
10. Transmitter OMNEO:
 - This device allows for wireless language distribution.
11. Powering switch:
 - Used to increase the number of DICENTIS devices connected to the system.
12. Audio processor and powering switch:
 - Controls the system audio, routes audio from and to the system and supplies power to the DICENTIS devices.
13. System Network Cable:
 - Connects DICENTIS devices, the Audio processor and powering switch, and one or more Powering switches to each other.
14. Discussion device:
 - The participant devices and interpreting devices can be powered via PoE. When powered via PoE, only star wiring is possible.
15. Integrus Radiator:
 - Through infrared distribution, the signals from the INT-TXO are transmitted to the radiators in the room.
16. Participant Application:
 - The Participant Application runs on an Android device. For audio, a tabletop or flush-mounted participant device is required.
17. Integrus Pocket Receiver:
 - The pocket receivers collect the signals sent by the radiators.
18. Flush base device:
 - This device is intended for use in flush-mounted solutions, adding a number of functions.
19. Interpreter Desk:
 - Provides extensive facilities for professional interpretation for the DICENTIS Conference System.
Note: A maximum of 10 desks can be installed per booth.

A typical camera setup in a DICENTIS Conference System consists of:

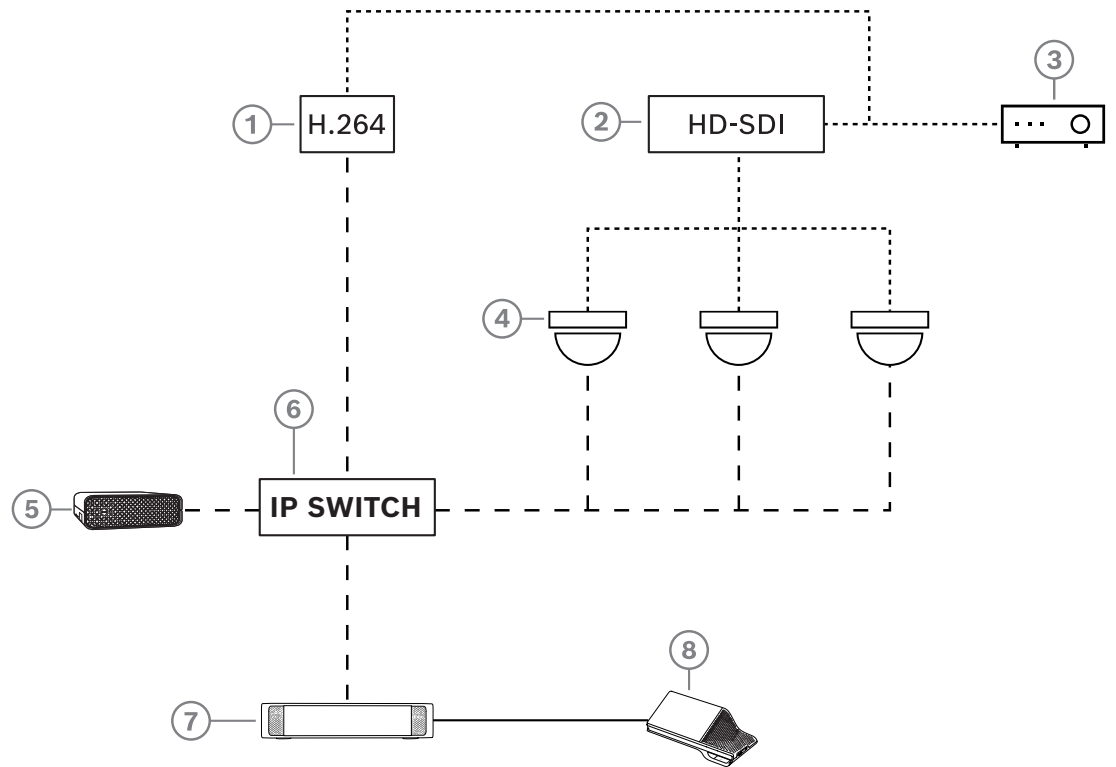

Figure 3.2: Typical camera setup

1	H.264 encoder to encode the HD SDI video to H.264 if the video camera is not able to supply the supported H.264 stream	2	HD-SDI switcher to switch the HD-SDI streams of the cameras
3	Projector to show the active speaker on the large screen	4	Video camera (Onvif Profile-S compatible camera, Sony, Panasonic)
5	DCNM-SERVER3	6	L3 Ethernet switch
7	DCNM-APS2	8	DCNM-MMD2, displaying the active speaker on the device
.....	HD-SDI (coax cable)	-----	Ethernet TCP/IP
_____	DCNM-Cables		

DICENTIS software suite

The DICENTIS Conference System software is used:

- To control and monitor a DICENTIS Conference System.
- To control a meeting, which is held in a room.

Each meeting consists of an agenda with several topics, and each topic has a discussion.

The DICENTIS software suite consists of two major parts:

1. The DICENTIS software server.
2. The **Meeting application**.

DICENTIS software server

The DICENTIS software server is a set of windows services. These services do not have a user interface and are run in the background to control and monitor all of the DICENTIS devices and client PCs running the Meeting application. The software server also includes a license activation module. This module is required for activating the license of the DICENTIS Conference System, as well as adding and returning fulfillments (a fulfillment consists of one or more licenses) See *Adding and removing licenses*, page 28.

DICENTIS Meeting application

The DICENTIS Meeting application acts as a PC user interface for configuring the system and preparing and managing meetings.

The PC running the services acts as a server for controlling the system and requires no user interaction in an operational DICENTIS Conference System. Basic functions for managing a meeting are available in the multimedia device. Optionally, the Meeting application can be installed on the server PC to control and monitor the meeting. If required, the Meeting application can be installed on a client PC instead. This means that the server PC can be installed in a 19" rack instead, which is normally located in a technical room. It is possible to have multi PCs running the Meeting application simultaneously.

The system audio is controlled by the DICENTIS Audio processor and powering switch (DCNM-APS or DCNM-APS2). This means that the system will not have audio when an Audio processor and powering switch is not present.

3.1 Hardware requirements

System requirements

This section lists the minimal requirements for each part of the system.

Refer to the *System overview*, page 11 sections for an overview of which parts are required or optional.

PC

The minimal PC requirements for the computer running the services in a DICENTIS system are:

- Up to 100 devices without identification or participants images.
- Up to 100 devices with identification or participants images.
- Up to 1500 devices without identification or participants images.
- Up to 1500 devices with identification or participants images.

The PC running the server software (Meeting application optional) can be either:

- Windows Server 2022, or
- Windows Server 2019.

For each use the minimal requirements are:

Number of devices	< 100 without identification or participant images
CPU Mark	>= 6000*
RAM	8 GB
Free disk space	20 GB

Ethernet card	1 GB
Number of devices	< 100 with identification or participant images
CPU Mark	>= 7000*
RAM	16 GB
Free disk space	50 GB
Ethernet card	1 GB
Number of devices	<= 1500 without identification or participant images
CPU Mark	>= 9000*
RAM	16 GB
Free disk space	50 GB
Ethernet card	1 GB
Number of devices	<= 1500 with identification or participant images
CPU Mark	>= 10000*
RAM	16 GB
Free disk space	50 GB
Ethernet card	1 GB

PC running the Meeting application only	
Up to 1500 devices with or without identification or participant images	Windows 11 Note: Windows 11 is only suitable for use with the client PC.
CPU Mark	>= 6000*
RAM	8 GB
Free disk space	20 GB
Ethernet card	1 GB

Note: The power of the processor is measured by a CPU Mark score, because this gives a more reliable benchmark score than just the processor family:

- many different processor brands and families are available
- a processor intended for a laptop is not as powerful as the processor intended for a desktop, although both can be for example, an i7
- newer versions of the same processor are faster than older versions

To check the CPU Mark score of a processor

1. Go to https://www.cpubenchmark.net/CPU_mega_page.html.

2. Enter the processor (for example, i7-12700) in the CPU Name text box.
3. Check the CPU Mark column for the CPU Mark score (for example, i7-12700 scores 31114).

Alternatively, you can clear the textbox CPU Name and sort the CPU Mark column and see which processor scores above, for example, 7000.

Switches

The following minimum requirements and recommendations apply to switches used in a DICENTIS:

Requirement	Standard	Settings
Gbit Ethernet	IEEE802.3	Switch latency is maximally 10µSec with Gbit. Valid for both copper and/or fiber ports.
Packet forwarding in HW per port >1.2Mpps	n.a.	If SW is responsible for packet switching, this would result in variable latency which is unacceptable.
Quality of Service With strict priority	DiffServ	To make sure PTP synchronization packets and audio packets get priority over control packets. OMNEO uses QoS on IP level to avoid synchronization and audio problems on busy networks. Although the system does work without problems on relatively quiet networks (< 10% network load) it is important to configure your network switches correctly. The used QoS is Differentiated Services or DiffServ, which is part of the Type of Services field (ToS) in the IP header. For more details on DiffServ & IP header, see Wikipedia.

Warning: IEEE802.1p is also used for QoS, but is limited to layer 2. Since OMNEO uses IP communication, this mechanism is not suitable, so make sure the used equipment uses DiffServ QoS!

The table below gives an overview of the used **DSCP values** which need to be configured in the switch:

Data	DSCP dec	DSCP hex	DSCP Label	TOS byte (hex)	Switch Priority queue
PTP sync, delay req	56	0x38	CS7	0xE0	Highest
PTP follow-up, delay response, audio	46	0x2E	EF	0xB8	High
(reserved)	8	0x08	CS1	0x20	Low

Control	0	0x00	Best effort	0x00	None
---------	---	------	-------------	------	------

Warning: Please check thoroughly if your switch’s highest priority queue is label as #1 or e.g. #8, because this may differ per brand. Unfortunately this is not consistent over the different brands. Setting it wrong is worse than not having priority.

Switches must be configured to support DiffServ (DSCP) quality of service The switch needs to have 4 priority queues for the DiffServ mechanism to work.

Warning: Never use VOIP QoS settings!

Requirement	Standard	Settings
MAC table >1000	n.a.	To avoid the switch starts broadcasting unicast packets because it runs out of space.
Disable EEE	IEEE 802.3az	Most implementations of EEE cause problems because of implementation flaws. A good implementation should work, but does not save energy since the PTP synchronization avoids this. Therefore, EEE (green or low power Ethernet) <i>must</i> always be disabled.
Disable RSTP (when no cable loops are used)		Rapid Spanning Tree Protocol (RSTP) is required when (cable) loops are created for redundancy. When no loops are created, RSTP needs to be <i>disabled</i> for optimal operation. When enabled, it can cause slow connections to the switch.
Possibility to create VLANS	n.a.	VLAN separation is recommended instead of IGMP snooping, because most switches are unable to handle the multicast changes in the system. Filtering multicast data may be necessary for some devices, such as 100 Mb devices (Sony cameras, TVOne, AMX, and others).
IGMPv3 IGMPv2 snooping in hardware		IGMPv3 or IGMPv2 snooping. To optimize bandwidth usage, IGMP snooping can be used. This is useful in systems with >10 multicast streams, although not absolutely required. Sufficient performance for handling a large number of IGMP query responses, depends on the number of (directly or indirectly) connected devices to that switch. Hardware support for IGMP snooping is strongly recommended.
Requirements when Redundant wiring is used	Standard	Settings
RSTP	IEEE802.1D-2004	RSTP is used to allow the creation of loops for redundancy. The switch must support changing the following parameters to the listed values: <ul style="list-style-type: none"> – Hello_Time = 9 seconds

Requirement	Standard	Settings
		<ul style="list-style-type: none"> - Forwarding_delay = 30 seconds - Max_age = 22 seconds
Diagnostics		
Link Layer discovery	IEEE 802.1AB	For network diagnoses using Network Docent.
SNMP	SNMP	For network diagnoses using Network Docent.

Routers

The following minimal requirements apply to routers:

- 1 Gbit or higher Ethernet ports.
- Supports PIM-DM or Bidirectional PIM.
- Performs IP routing in hardware (i.e. a 'layer 3 switch') to minimize the routing delay.
- Packet forwarding rate > 1,000,000 packets per second per port (e.g. 8 Mpps for an 8-port router).
- Non-blocking backplane per switching port, i.e. 2 Gbit per port (e.g. 16 Gbps for an 8-port router).
- MAC address table of at least 1000 addresses per directly connected subnet.

Tablets

The following recommended requirements apply to the tablets running the Participant Application:

Specification	Recommended
Operating system	Android 11 or higher
Screen resolution (pixels)	1920 x 1080 px or higher
CPU ¹	Snapdragon Gen 6 or better (Passmark > 8000, CPU Score > 4000)
Video decoder ²	Hardware H264 and H265 (HEVEC) video decoding
Video encoder	Hardware video encoding H264/H265
Memory	Min. 4 GB
Connectivity ³	Min. 1 Gb/s wired Ethernet connection

1 - Refer to <https://www.androidbenchmark.net/> to check the CPU Mark score of the chipset.

2 - Video decoder performance may vary due to differences in Android devices. It is recommended to test the Android device with a DICENTIS Conference System to verify the video performance.

3 - If the device does not have an integrated Ethernet port, it is required to use an external Ethernet to USB-C adapter with minimum 1 Gb/s speed to connect to the DICENTIS network. It is recommended to use an adapter that supports pass-through charging.

3.2 Network requirements

If the DICENTIS Conference System is being used as a standalone system, it uses the so-called dynamic link-local addresses. This means that the TCP/IPv4 setting of the server PC and client PCs need to be set to "Obtain an IP address automatically". Normally, these settings are default and therefore do not require PC network configuration settings. In case more functionality is required, for example, internet access, the dynamic link-local addresses cannot be used. In this case the DICENTIS devices and PCs need to be connected to a DHCP server and gateway to provide internet access. If the DICENTIS Conference System will become part of a locally present network, contact your local IT department for how to set up the network.

The DHCP server has to comply with RFC 4676 and must be able to handle 500 requests per 30 seconds. A consumer grade DHCP server as is used in most home router/wireless access points is not able to comply with this requirement and will cause unexpected and unrequested behavior.

The DHCP server functionality of Windows server does comply with these requirements. The DICENTIS Conference System service uses ports 13 and 9710 for communication. Please make sure that these ports are not used by any other applications on the DICENTIS server computer.



Notice!

The IGMP (Internet Group Management Protocol) should be enabled on the DICENTIS network switches for better video quality on the Participant Application. You can use the blueprint provided under Technician > Tools to configure the network switches suggested by Bosch.



Notice!

How to set up an Ethernet network is outside the scope of this manual.

3.3 Software requirements

For the server PC, DICENTIS requires:

- Windows Server 2022 (including .NET Framework 3.5 feature). This version must have the latest service packs and updates installed.

Note: set the Network profile for the Network adapter running the DICENTIS services to Private (not Public) so that ONVIF cameras can be discovered and to prevent unnecessary logging.

3.4 License requirements

Before the DICENTIS Conference System can be used, you have to:

1. Install the DICENTIS System Server Software on the server PC. See *Installing the DICENTIS software suite, page 27*.
2. Activate the DICENTIS software.

Additional licenses can then be purchased to add functionality to the system. See *License overview, page 20*.

3.4.1 License overview

The DICENTIS system offers a participant based licensing model with:

Features	Out of the box	Premium	Ultimate
Discussion modes			
– Open (automatic)	✓	✓	✓
– Open (normal)	✓	✓	✓
– First in first out	✓	✓	✓
– Response	-	✓	✓
– Voice	✓	✓	✓
◦ Included voice activated microphone logging which can be used for automatic camera control in voice mode	-	-	✓
– Speech timer per speech turn	-	✓	✓
– Discussion modes can be set per agenda item	-	✓	✓
Meeting and Agenda			
Identification configuration	-	✓	✓
Quorum configuration	-	✓	✓
Assignment of participants to meetings	-	✓	✓
Assignment of rights to participants (VIP, priority, meeting manage, voting, weighted voting)	-	✓	✓
Assignment of participants to seats	-	✓	✓
Agenda items	-	✓	✓
Discussion settings per agenda item	-	✓	✓
Request list per agenda item	-	✓	✓
Interpretation configuration per meeting	-	-	✓
Participants			
Participant details	-	✓	✓
UI language	-	✓	✓
Preferred headphone language	-	✓	✓
Audible beeps for voting	-	✓	✓
Display the participant image	-	✓	✓

Features	Out of the box	Premium	Ultimate
ID by NFC	-	✓	✓
Username	-	✓	✓
PIN-code	-	✓	✓
Password	-	✓	✓
Voting (only participant with voting rights can vote)			
Voting settings can be configured for an Ad hoc voting round	-	✓	✓
An ad hoc voting round can be run. Before activating the voting round it is possible to enter number, subject and description	-	✓	✓
Voting rounds can be pre-prepared as part of the meeting preparation	-	-	✓
The voting round results are stored in the voting file per voting round and meeting notes	-	✓	✓
Interpreting, language distribution and selection			
Interpreting from DCNM-IDESEK/DCNM-IDESEKVID	✓	✓	✓
Language distribution to INT-TXO, OMN-DANTEGTW, DCNM-FSL (or to Dante multicast streams by adding DCNM-LDANTE)	✓	✓	✓
Language selection by participants on their device, based on the number of participant licenses	-	✓	✓
Interpretation configuration can be done via Meeting Application	-	-	✓
Interpreting control via Synoptic	-	-	✓
Interface for Interpreting control if other source than DICENTIS interpreter desk delivers the interpreting (e.g. RSI)	-	-	✓
System			
Audio processing	✓	✓	✓
Seat configuration	✓	✓	✓
Configuration of the device for use by 2 participants	✓	✓	✓
Assign identification, voting and language selection functionality to Seat	-	✓	✓

Features	Out of the box	Premium	Ultimate
Camera control and Hall display			
Support of ONVIF, Panasonic and Sony Cameras	✓	✓	✓
Support of Kramer MV6 and TvOne Coriomatrix video switch to show active speaker or overview on a hall display	✓	✓	✓
Overview or active speaker view on Multimedia device, Interpreter desk with video support and Meeting application	✓	✓	✓
Show first / last speaker	✓	✓	✓
Active speaker or overview image display	✓	✓	✓
Software video switcher for low latency video on a hall display	-	✓	✓
Full screen video and mosaics with multiple participants	-	✓	✓
Overlay of speaker name on the video	-	✓	✓
Multiple output video feeds for different purposes (e.g. 1 for display on the hall display and 1 for the Interpreter desks)	-	✓	✓
Display of a presentation on the hall display, multimedia device, interpreter desks and Meeting application	-	✓	✓
Licenses			
	It is required to register the system, but no license is required.	<ul style="list-style-type: none"> - DCNM-LPP-PE - DCNM-LPPP-P1Y - DCNM-LPPP-S1Y 	<ul style="list-style-type: none"> - DCNM-LPU-PE - DCNM-LPUP-P1Y - DCNM-LPUP-S1Y
Number of licenses			
For each participant present in the meeting a participant license is required	-	✓	✓
Only participants can participate in voting	-	✓	✓
Only participants can select a language on a participant device (device where a microphone can be connected)	-	✓	✓

Features	Out of the box	Premium	Ultimate
For seats where no participant is seated, e.g. an audience microphone, no participant is required (it cannot select a language, nor participate in voting)	✓	✓	✓
Activating the functionality			
This functionality is enabled via the Activation Tool	Upon system registration	1 license per participant	1 license per participant

Table 3.1: DICENTIS license service comparison

	End date	Software maintenance	Participant App
After registration	No end date.	Included.	Not included.
Perpetual license	No end date.	1 year after activation. By adding DCNM-LPSMA-PE licenses, the duration can be extended. The same number of DCNM-LPSMA-PE licenses as Perpetual licenses is required.	In a system with perpetual licenses, one app can be connected as part of the license plan. To increase the number of connected apps, DCNM-LPAPP-PE licenses are required. The number of connected apps cannot exceed the number of perpetual licenses.
Prepaid license	1 year after activation. By adding new Prepaid licenses, the duration can be extended.	Included while the prepaid license is valid.	One app can be connected per participant with a valid prepaid license.
Subscription license	1 year after activation. It will be automatically extended. It needs to be ended by the customer.	Included while the subscription license is valid.	One app can be connected per participant with a valid subscription license.

Please note that your system cannot work with different types of licenses activated. Your system can have:

- Premium licenses only, or
- Ultimate licenses only.
- Perpetual licenses only, or
- Prepaid licenses only, or

- Subscription licenses only.

Licenses:**DCNM-LPP-PE Participant premium perpetual**

The DCNM-LPP-PE is a participant based perpetual license that enables the premium feature pack. It contains features to enable voting and interpreting functionalities together with multiple identification options.

DCNM-LPU-PE Participant ultimate perpetual

The DCNM-LPU-PE is a participant based perpetual license that enables the ultimate feature pack. It contains the complete set of features to enable advanced voting and interpreting functionalities together with multiple identification options.

DCNM-LPAPP-PE Participant application perpetual

The DCNM-LPAPP-PE is a license that enables the participants to access the Participant Application, which offers more multimedia content and enhanced functionality. It can be added to systems with perpetual licenses. The number of DCNM-LPAPP-PE licenses determines the number of participants that can use the app. Up to 300 Participant Applications are supported.

DCNM-LPSMA-PE Software Maintenance Agreement

The Software Maintenance Agreements (SMA) extends the software maintenance period for one year. It includes the licensed system and seat software upgrades, as well as third-party compatible updates. One SMA is required per participant license.

- Enables best-possible system performance
- Convenient upgrade of software instead of expensive hardware
- Regular updates

DCNM-LPPP-P1Y Participant premium pro prepaid

The DCNM-LPPP-P1Y is a participant based yearly prepaid license that enables a premium feature pack. The premium feature pack enables a voting and interpreting functionality together with multiple identification options. The meeting manager can prepare and manage the meetings easily and effectively using the powerful DICENTIS Software.

DCNM-LPUP-P1Y Participant ultimate pro prepaid

The DCNM-LPUP-P1Y participant based yearly prepaid license plan enabling the ultimate feature pack for participants. It contains all features to enable advance voting and interpreting functionalities together with multiple identification options. The meeting manager can prepare and manage meetings in an easy and effective way using the powerful DICENTIS Software Suite.

DCNM-LPPP-S1Y Participant premium pro automatic subscription

The DCNM-LPPP-S1Y is a participant based perpetual license that enables the premium feature pack. It contains features to enable voting and interpreting functionality together with multiple identification options. The meeting manager can prepare and manage the meetings easily and effectively by using the powerful DICENTIS Software Suite.

DCNM-LPUP-S1Y Participant ultimate pro subscription

The DCNM-LPUP-S1Y is a participant based yearly subscription license plan enabling the ultimate feature pack for participants. It contains the complete set of features to enable advanced voting and interpreting functionalities together with multiple identification options. The meeting manager can prepare and manage meetings in an easy and effective way using the powerful DICENTIS Software Suite.

DCNM-LDANTE DICENTIS License for 1 Dante stream

This software license enables the sending or receiving of Dante audio streams, allowing the interfacing of the DICENTIS Conference System with other systems based on Dante and providing the ability to record the interpreted languages or to interface with a 3rd party discussion or interpreting system.

- Enables sending up to 100 interpreted languages as Dante audio streams
- Enables receiving up to 100 interpreted languages as Dante audio streams
- One license per stream required

3.5 Security measures

The installer takes care of security measures to prevent improper use of the system via the Internet and local wired or wireless networks.

Consider the following items to increase security:

- Change the default admin password
- Prevent unauthorized access to the DICENTIS server computer
- Prevent unauthorized physical and logical access to the wired Ethernet connection of the DICENTIS network
- Place the DICENTIS network in a separate VLAN
- Use a firewall
- Install the latest Windows security updates
- Install up to date virus scanner
- Set a PIN code on each Dante™ device (see *Setting a PIN code for a Dante™ device*, page 149 for detailed instructions)

Schedule your Windows updates to run at a time when the system is not used, e.g. Sunday morning at 1 AM. If you schedule the update via the Windows Task Manager, you can also configure that it automatically reboots after the update, in case a reboot is required.

3.6 GUI languages

The DICENTIS Conference System has the following GUI languages:

	Multimedia device	Discussion device with touchscreen	Meeting application / Server Console / Activation tool / Certificate manager	Webserver	Activation website
Arabic	✓	✓	✓	✓	-
Burmese	✓	✓	✓	✓	-
Catalan	✓	✓	✓	✓	-

Croatian	✓	✓	✓	✓	-
Czech	✓	✓	✓	✓	-
German	✓	✓	✓	✓	✓
English	✓	✓	✓	✓	✓
Spanish	✓	✓	✓	✓	✓
Estonian	✓	✓	✓	✓	-
Finnish	✓	✓	✓	✓	✓
French	✓	✓	✓	✓	✓
Hebrew	✓	✓	✓	✓	-
Hungarian	✓	✓	✓	✓	-
Indonesian	✓	✓	✓	✓	✓
Italian	✓	✓	✓	✓	✓
Japanese	✓	✓	✓	✓	✓
Korean	✓	✓	✓	✓	✓
Lao	✓	✓	✓	✓	-
Latvian	✓	✓	✓	✓	-
Lithuanian	✓	✓	✓	✓	-
Dutch	✓	✓	✓	✓	✓
Polish	✓	✓	✓	✓	✓
Portuguese PT	✓	✓	✓	✓	✓
Portuguese BR	✓	✓	✓	✓	-
Romanian	✓	✓	✓	✓	-
Russian	✓	✓	✓	✓	✓
Serbian	✓	✓	✓	✓	-
Slovak	✓	✓	✓	✓	-
Slovenian	✓	✓	✓	✓	-
Thai	✓	✓	✓	✓	✓
Turkish	✓	✓	✓	✓	✓
Ukrainian	✓	✓	✓	✓	-
Uzbek	✓	✓	✓	✓	-
Vietnamese	✓	✓	✓	✓	✓
Chinese Simplified	✓	✓	✓	✓	✓
Chinese Traditional	✓	✓	✓	✓	-

4 Software installation

Before the DICENTIS Conference System can be used, it needs to be configured.

Configuration of the system is done in the following order:

- **Network installation:**
 - This is not part of one of our Bosch Security Systems B.V. manuals, and needs to be defined together with your local IT department. Refer to *Hardware requirements, page 14* and *Network requirements, page 19*.
- **Installation of hardware devices:**
 - This is not part of this manual. Refer to the DICENTIS Hardware Installation manual. Refer to the product related information on www.boschsecurity.com.
- **Installation of software:** *Installing the DICENTIS software suite, page 27.*
- **Activate the system and application software by registering the software:** *Adding and removing licenses, page 28.*
- **Update device (firmware) software:** *Downloading software to the devices, page 27.*
- **Configuration of system and application software:** *Meeting application, page 35.*

4.1 Installing the DICENTIS software suite

Configure network interface

**Notice!**

Before installing the DICENTIS software, make sure the server PC has only one enabled network interface (Bluetooth is also seen as a network interface).

Download and install latest version of DICENTIS System Server Software from the Internet

1. Go to: <https://licensing.boschsecurity.com/software>
2. Click the **Software** link (small square) to download the latest version of the software. You can also download the latest version of the Release Notes here.
3. Follow the on-screen instructions.

**Notice!**

During the system software installation, the application WinPcap will be installed as part of the Network Dozent package.

If you cancel the WinPcap installer, the system software installation process will fail. Simply restart the installation process and follow the steps in the WinPcap installer.

**Notice!**

After installing/upgrading the System Server Software, make sure you download the latest version of the software to the devices, as described in *Downloading software to the devices, page 27*.

4.2 Downloading software to the devices

- Factory delivered DICENTIS devices are delivered with diagnostics software and must be upgraded to the latest software version before they can be used.
- All DICENTIS devices must be upgraded after upgrading the System Server Software.

To do this:

1. Make sure all devices are correctly connected to the network and fully started.
2. Right-click the **DICENTIS Server Console** in the Windows taskbar.
3. Click **Upgrade devices**.

Use this procedure to upgrade other hardware components, such as the DCNM-APS2, as required.



Notice!

Close the FWUT after upgrading the devices. Not doing so might cause other applications to malfunction.



Notice!

It is not advisable to upgrade the devices at the same time as the DCNM-APS, because the DCNM-APS resets itself during the download process. This will remove power from the devices, which will cause a firmware upgrade of the devices to fail.



Notice!

In a DICENTIS system with an ARNI, a restart of the services via the Server Console may take up to 3 minutes. If you want to restart the services, please use the stop services function in the Server Console, wait for 30 seconds and then use the start services function in the Server Console.

4.3 Adding and removing licenses

The activation tool is used to:

- activate the DICENTIS system.
- synchronize your system with the activation website.
- process response files.



Notice!

If you activated your system in a pre-4.40 version, you can continue using the activation tool existent before the 4.40 version. You can also upgrade the activation tool to the latest version.

If you have...	Activation method
A pre-4.40 software version and want to keep using the existing activation tool	Use the chapter <i>For DICENTIS Conference System Pre-4.40, page 140</i> .
A pre-4.40 software version and want to upgrade to the new activation tool	Open the DICENTIS activation tool using the Upgrade button and use the new activation tool.
An unregistered 4.40 software version of the system	Use the new DICENTIS activation tool.

NOTE: After upgrading the license, all the functions, like adding or returning licenses, are managed on the activation website. Synchronize the activation tool with the activation website through the **Refresh** button (online) or by downloading the license from the activation website and processing it in the activation tool (offline).

Before the system can be used, the DICENTIS System Software has to be registered.

4.3.1

Activation tool description

- **List of licenses and quantity** window: For each license, this window shows: **Qty** (number of licenses), **Order number**, **Description**, **Activated** (activation date of license), and **Expires** (expiry date of license).

Note: The activation date of the license displayed is one day before the real activation day. The date displayed in the **Expires** field is correct.

- **Software Maintenance Agreement** bottom bar: Shows the Software Maintenance Agreement (SMA) end date. When the SMA end date has expired, it turns red and the additional red text **System is not operational! Additional SMA is required.** is displayed at the bottom of the window.
- **Remote participating certificate:** This certificate authenticates the DICENTIS server with the cloud services to enable the DICENTIS hybrid services, as well as the synchronization with the System Activation Site for the license of the DICENTIS server. It extends automatically when the system has Internet connection. If the system is offline for too long, the certificate expires and you need to extend it by clicking the **Refresh** button and inserting your credentials in the System Activation Site.
- **Device ID:** Shows the ID of your system.
- **Register system:** Use this button to register your system.
- **Manage licenses:** Use this button to manage the licenses of a registered system. The System activation website opens. Login with your credentials to access the **Manage devices** page.
- **Refresh:** Use this button to synchronize the Activation tool with the Activation website (online mode).
- **Process license file:** Use this button to process the license file you retrieve from the Activation website (offline mode)

After you click the **Refresh** or the **Process response file** buttons, the expired licenses disappear from the **Activation tool**. The expired licenses remain visible on the **System Activation Website**.

4.3.2

Initial registration of the system

Register the system for initial use as indicated below.

Before you start, make sure you have:

- Internet capable PC.
- USB stick (for offline activation).



Notice!

To perform the following steps, your user account must have “Technician rights”. The ‘Admin user’ of your organization can grant these rights.

Registering the system

The first time you open the DICENTIS Activation Tool, it allows you to click on the **Register system** button. Once you register for the first time, the **Register system** button changes to the **Manage licenses** button.

For information about the available features of the Out of the box licensing option, refer to *License overview, page 20*.

It is possible to register your system with both online and offline methods.

To register your system via the online method:

1. Right-click the **DICENTIS Server Console** in the Windows taskbar and then select **Activate licenses**.
2. Click **Register system**.
3. Enter the mandatory information.
4. Select the **Online** tab.
5. Enter the user's **E-mail** and **Password**.
6. Click **Register system**.
The progress message panel displays status messages during the registration process. Registration of the system is complete.

To register your system via the offline method:

1. At the server PC, right-click the **DICENTIS Server Console** in the Windows taskbar and then select **Activate licenses**.
2. Click **Register system**.
3. Enter the mandatory information.
4. Select the **Offline** tab.
5. Click in the **Create request** button. The system creates a request file.
6. Store the newly created **Request file** on a USB stick.
7. On a computer with Internet access, visit <https://licensing.boschsecurity.com>:
8. Log in to the Activation website with your username and password (with Technician rights).
9. Select the **Manage license** tab page.
10. Upload the **Request file** from the USB stick.
11. Click the **Process** button.
12. After processing the **Request file**, you get a message confirming that the processing was successful. Click the **Save to file** button to save the **Response file**.
13. On the server PC, restart the **Activation tool**.
14. Click **Register system**.
15. Click the **Offline** tab.
16. Click the **Process license file** button. A process file window appears.
17. Upload the **Response file** and click the **Process** button.
Registration of the system is complete.



Notice!

After successfully registering the system, you can manage licenses by clicking in the **Manage licenses** button in the DICENTIS Activation tool.

4.3.3 Adding/returning licenses



Notice!

The system activation website manages all licenses modifications.

To add and remove licenses, and to upload and download response files, go to the **Manage devices** tab on the System activation website. Refer to *Manage devices*, page 126.

4.4 Server console

The DICENTIS server console icon is displayed in the notification area of the DICENTIS server PC, i.e. on the right side of the taskbar next to the time.

After you add, update, or return a license, you receive a notification in the Server Console asking you to restart the services.

Right-click the **DICENTIS Server Console** to:

Start services / Restart services / Stop services.

- Use these options to manually Start/Restart/Stop the services.

Upgrade devices.

- Use the firmware upgrade tool to upgrade the devices to the latest supported version of the services (see *Downloading software to the devices*, page 27 for detailed information).

Manage database.

- Use this option to easily manage the database. The following actions are available:
 - Create a backup of current database.
 - Import a database and upgrade to the current version.
 - Create a clean database. Use this when you want to start with a clean configuration.
 - Import a database, but do not upgrade it. Use this when you want to downgrade to a previous DICENTIS version.
 - Delete the database. Use this when you want to downgrade to a previous DICENTIS version and start with a clean database.
- The **File location** field is used to select the backup or import location.
- Below on the **Manage database** window, you can see the progress of the selected action. The window closes once the action is successfully completed or cancelled.



Notice!

The DICENTIS services stop automatically when you start an action. They also restart automatically after the action is completed, except for the following actions:

- Import a database, but do not upgrade it. Use this when you want to downgrade to a previous DICENTIS version.
- Delete the database. Use this when you want to downgrade to a previous DICENTIS version.



Notice!

It is possible to import or upgrade a database that was created with a previous DICENTIS version. However, it is not possible to import a database created with a newer DICENTIS version.

Logging collector.

- Use this option to collect all the system, configuration, and logging information. Select the **Export DICENTIS database** checkbox if you want to include this data in the export.



Activate licenses.

- Click here to activate your licenses (see *Initial activation of the system*, page 140 for detailed information).

Start the activation tool.

- To add or remove licenses, see chapter *Adding and removing licenses*, page 28.

An icon showing the status of the DICENTIS server is displayed:

Status	Description
	Running. The services are automatically started if the system is registered (checked every 20 minutes), and if the system can connect to the database (checked every 60 minutes). Note: A network adapter with a valid IP address is required for the services to start.
	Stopped. Every 20/60 minutes, the system checks if the criteria are met and will automatically stop or restart the services depending on the status. If the services are stopped manually, the automatic check is also stopped. If the system license is extended or reduced, the services must be restarted to update to the current state.
	Warning. For example, this icon is displayed when a license is not activated.

How to permanently display the server console icon

By default, the server console icon is only displayed on event. To permanently display this icon:

1. Select the **Notification Area Icons** window:
 - Windows server 2012 R2 and Windows server 2016
Go to the Start screen and type notification. Filter the results by **Settings**, and then click **Notification Area Icons**.
2. Use the slider bar to scroll down to **DICENTIS Server Console**.
3. Select **Show icon and notifications**.
4. Click **OK**. The Server console icon will now be permanently displayed.

4.5

Rapid Spanning Tree Protocol (RSTP) support

The DICENTIS system supports redundant cabling when the Rapid Spanning Tree Protocol (RSTP) is enabled. By default RSTP is disabled to prevent network failures in a system where RSTP is not supported or allowed.

To enable cable redundancy:

1. Power up the system without cable redundancy.
2. Configure RSTP for **all** third party switches in the network.

Notice!

Only use third party switches that support RSTP and comply with IEEE802.1D-20 04.

The switch must support changing the following parameters to the listed values:

- Hello_Time = 9 seconds
- Forwarding_delay = 30 seconds
- Max_age = 22 seconds



3. Enable Rapid Spanning Tree Protocol (RSTP) in the DICENTIS server:
 - Create a system environment variable named DCNM_RSTP_ENABLED and set the value to 1 to enable RSTP, and 0 to disable RSTP.
 - The environment variable can be created via: File explorer > This PC, right click and select Properties > Advanced system settings > Advanced > Environment Variables > System variables.
 - Restart the DICENTIS server.
4. Wait until the system is fully started.
5. Restart all the DICENTIS central equipment, and all the DICENTIS discussion and interpretation devices. Third party switches do not need to be restarted.
6. Wait until the system is fully started. The devices can then be cabled redundantly (loops can be closed).

4.6 Creating certificates for web-based clients

Use the Certificate Manager to create and manage certificates to use the Synoptic control in web-based clients without security warnings.

To create and manage certificates, open the Certificate Manager via the Start menu and fill in the required information in the **Manage certificates** screen.



Notice!

To create and manage certificates, the user needs Windows administrator rights.

Root certificate

If you already have a Root certificate, select the folder icon to search for the existing certificate and fill the **Root certificate password** field with the password.



Notice!

When you use an existing Root certificate, the Root certificate .pfx and .crt files need to be in the same folder, and their names are: <name>-private.pfx and <name>.crt.

If you do not have a Root certificate, use the **Create** button to create a new Root certificate.

Create root certificate

- **Root certificate:** enter the name of the new Root certificate.
 - **Path:** select the folder where the new Root certificate will be saved.
 - **Root certificate password:** enter a secure password for the new Root certificate.
- Click **Create root certificate** to return to the **Manage certificates** screen and the Root certificate details will be entered automatically.

Server certificate

- **Server certificate:** enter the name of the new Server certificate.
- **Path:** select the folder where the new Server certificate will be saved.
- **Server certificate password:** enter a secure password for the new Server certificate.

- **DNS names:** enter all the DNS names of the DICENTIS Server.
- **IP addresses:** enter all the IP addresses of the DICENTIS Server.

**Notice!**

You need to create a new Server certificate when the hostname or the IP address of the server changes. You can use the same Root certificate, so the clients do not need to install a new Root certificate.

Click **Create and install** to create and install the new Server certificate and make the Root certificate available for download at the Synoptic browser and install it.

Click **Create** to create the Server certificate. You can then install it at a later moment in time.

Hint: If you have multiple DICENTIS servers at your site to which clients need to connect, create the Root certificate on 1 server and use it on the other servers to create the server certificate. This way, the clients only need to install 1 Root certificate to access all the DICENTIS servers.

Refer to *Creating certificates using the command line tool*, page 151 for more information.

4.7

Installing the Participant Application

The Participant Application is a native app that runs on standard Android tablets and works as an extension of the discussion devices, by offering the participants more multimedia content and enhanced functionality. The tablets need to be connected to the DICENTIS network to install and run the application. Please use a wired network connection to enable the highest possible performance.

To install the app on a tablet, follow the steps below:

1. Log in to the DICENTIS Webserver.
2. Click on the **Participant App Setup** tab.
3. Follow the instructions on the **App Install Guide** page.

You can download the installation package by scanning the QR code or clicking the link.

Once a tablet is connected to the server network and the installation is completed, the app automatically detects the server and connects to the DICENTIS services. When the app is unable to connect to the server, make sure the DICENTIS services are operational and the tablet is connected to the same network as the DICENTIS server.

**Notice!**

In order to ensure a safe connection, make sure that no unauthorized discovery services are running inside the DICENTIS network.

Before a tablet can be used in a meeting, it needs to be registered and configured in the Meeting Application. For more information, refer to *Participant Application*, page 75.

5 Meeting application

The meeting application consists of four main parts (only available with the applicable license):

1. *Manage, page 40*: To manage a meeting.
2. *DICENTIS Webserver, page 91*: To configure and manage synoptic microphone control.
3. *Prepare, page 45*: To prepare a meeting.
4. *Configure, page 62*: To configure the DICENTIS system.

Starting the Meeting application

1. From the **Windows Start menu**, select: **All Programs > Bosch > DICENTIS > Meeting application**. A Login dialog is displayed.
2. To log in to the application, enter a **User name** and **Password**.
The preferred application **language** can also be selected.

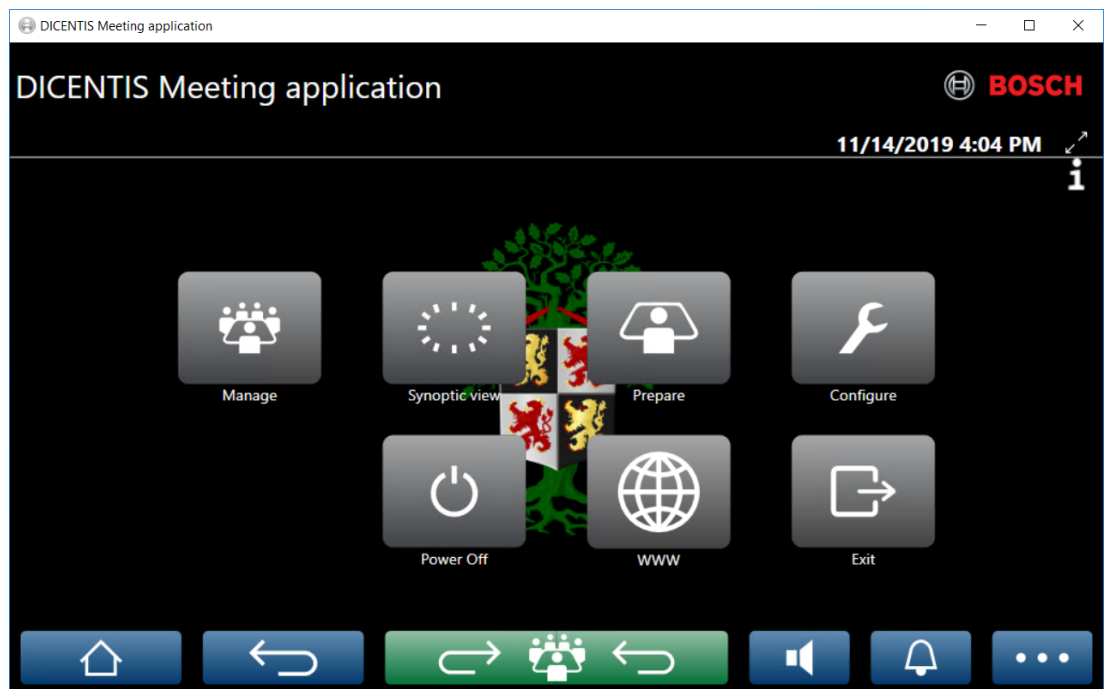

Figure 5.1: Meeting application main screen (showing all icons)

Moving and resizing the Meeting application

The Meeting application window can be toggled between fullscreen and windowed using the ↶ ↷ and ↷ ↶ icons on the top right corner of the screen next to the date and time.

You can move the window by clicking and holding the title bar of the application window. You can also resize the window by dragging the edges/corner.

The size and location of the window are saved after exiting the application.

Automatic login to Meeting application

By default, the DICENTIS Meeting application will automatically log in when the windows login user name is the same as a user name in the DICENTIS system. In this case, the authorization rights of this user will be used for the DICENTIS Meeting application.

**Notice!**

The default **User name** is “**admin**” and the **password** is empty. The default **language** is the language of the operating system; if the default language is not available, English is automatically selected.

For security purposes, it is advised to change the default password to a new password.

Disable/enable automatic login to Meeting application

The automatic login feature can be disabled and enabled as follows:

1. In Windows explorer, select: **C:\Programs (x86)\Bosch\DICENTIS**.
2. Open: **Bosch.Dcnm.UserInterfaces.MeetingManager.exe.config**.
 - To disable automatic login, set the key from **true** to **false**.
`<add key="ENABLE_AUTOMATIC_WINDOWS_AUTHENTICATION_TO_LOGIN" value="false"/>`
 - To enable automatic login, set the key from **false** to **true**.
`<add key="ENABLE_AUTOMATIC_WINDOWS_AUTHENTICATION_TO_LOGIN" value="true"/>`

Authentication via Windows Server

It is possible to synchronize the user and password data between the corporate network and the DICENTIS Conference System. Users who are part of the organization are often already registered in the Microsoft system with their username and password. When this option is enabled, users can log in to the discussion device with the same user name and password they use for Windows authentication. The user name and password will be validated on their computers on the corporate network.

The authentication service is normally part of the corporate network. The IT department wants the DICENTIS system to be isolated from the corporate network because they do not want the multicast traffic (the audio) to influence the corporate network. The DICENTIS system should have access to the corporate network without being part of the corporate network. This can be solved as follows:

- Create a separate subnet on a different VLAN, for the DICENTIS system in the network.
- Create routing between the DICENTIS and corporate subnets.

Note: Do not use a second NIC for the DICENTIS server to create a solution with the DICENTIS server as step-stone between the DICENTIS system and corporate network.

- Test if everything is working by accessing a share on a file server, using a computer which belongs to the corporate domain. See schematic below.

The meeting application consists of four main parts (only available with the applicable license):

1. *Manage, page 40*: To manage a meeting.
2. *DICENTIS Webserver, page 91*: To configure and manage synoptic microphone control.
3. *Prepare, page 45*: To prepare a meeting.
4. *Configure, page 62*: To configure the DICENTIS system.

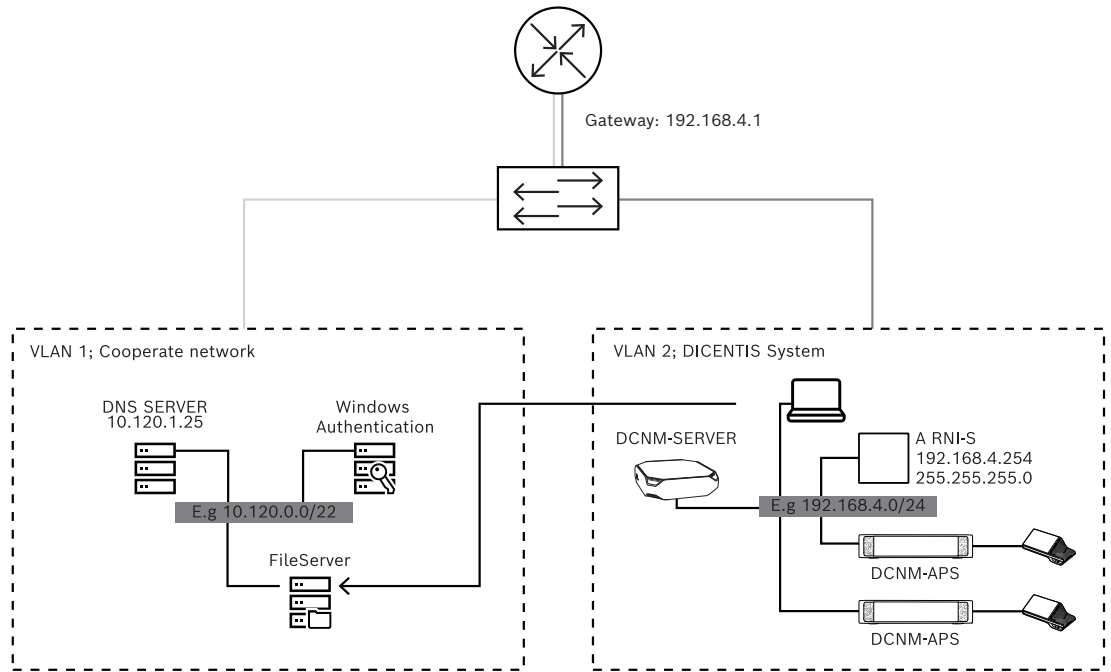

Figure 5.2: System diagram

For a DICENTIS Conference System with more than 450 nodes an ARNI is required. To configure a system with ARNI:

- Define a proper gateway address in the ARNI, so that routing to the corporate network will work.
- Use the ARNI as the DHCP server for the DICENTIS subnet.
- Configure the DNS Parent address; this is the address of the DNS server in the corporate network.

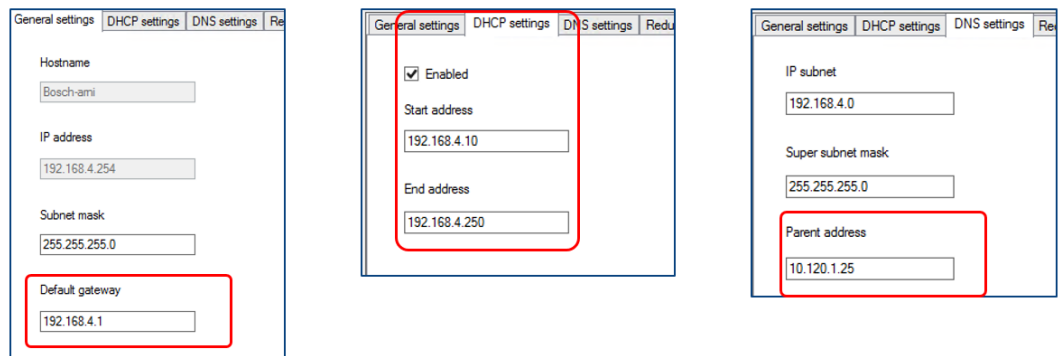

Figure 5.3: Configuration for a system with ARNI

To enable authentication via the Windows Server:

1. Make sure all persons using the multimedia devices in the central system which uses Windows authentication server are registered (including first name, last name, user name and password). The username must be identical to the username assigned to these users in the Windows authentication system.
2. Configure the user group “Participant group” to use Windows Server authentication:
 - Open **Configure** in the Meeting Application.
 - Go to **User groups**.
 - Select **Participant group**.
 - Tick **Windows Authentication**.

See also *User groups*, page 62.

Note: Windows authentication is applied per user group. User groups from outside the organization (like Service technicians) are usually not registered in the customer's authentication system. For these groups do not enable **Windows Authentication**. This means their password has to be stored in the Meeting Application.

5.1 User rights and meeting rights

To use functions, certain rights are needed. DICENTIS provides two types of rights:

1. **User rights**
 - User rights are defined in *User groups, page 62*.
2. **Meeting rights**
 - Meeting rights are defined **per seat** and **per participant** in a meeting.
 - Refer to *Seat assignment*.
 - Refer to *Participants, page 55*.

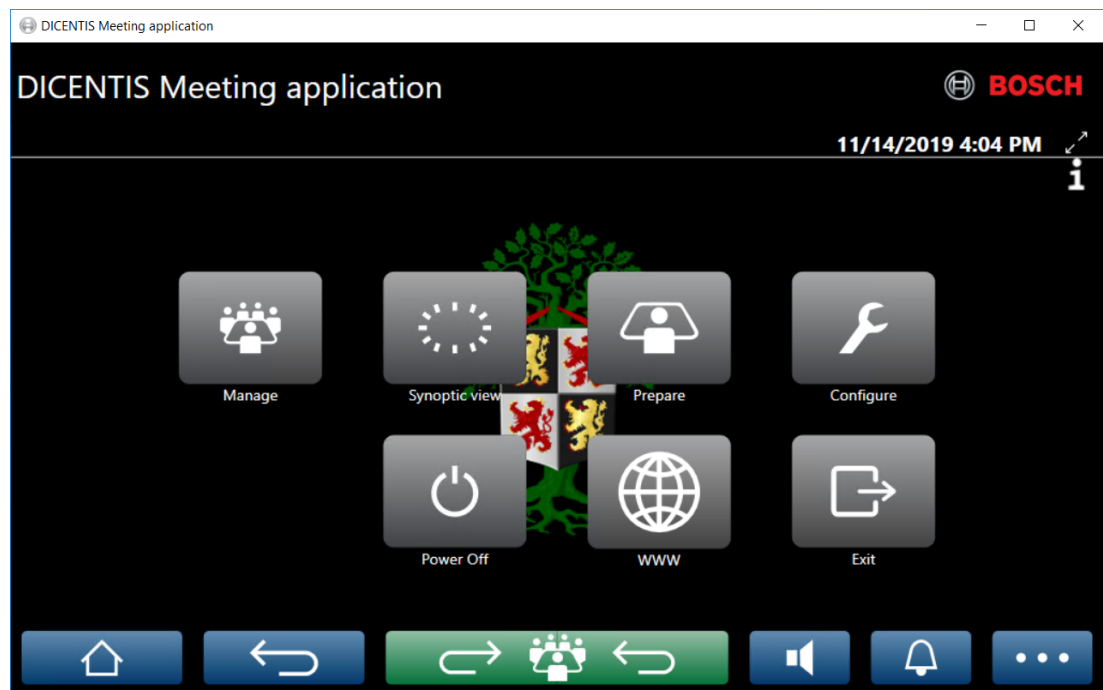







Figure 5.4: Meeting application main screen (showing all icons)

(Touch) button	Description	User rights	Meeting rights
Manage	To manage meetings.		Manage meeting.
Synoptic view	To configure and manage the speakers' microphones via a visual layout.	Configure system (to be able to configure the layout).	Manage meeting (to be able).
Prepare	To prepare meetings.	Prepare meeting and agenda.	
Configure	Configure the system.	Configure system.	

(Touch) button	Description	User rights	Meeting rights
Power	Sets the system to standby or wakes-up the system.		Device right: Power off.
WWW	Opens a web browser.		
Exit	Exits the application.		
Home 	Returns to the home screen of the meeting application.		
Back 	Goes one page back from the navigation history.		
Back to active 	Brings you to the active part of the meeting.		
Volume 	Opens the master volume control slider.		Device right: volume control.
Summon 	Activates a chime to summon the participants.		Manage meeting.
Menu (...) 	Opens a menu for additional functionality.		Manage meeting.



Notice!

The “Power On” button on the Meeting application, or on a DICENTIS multimedia device connected to the low power socket of the Audio processor and powering switch, only wakes up DICENTIS devices that are powered by an Audio processor and powering switch or Powering Switch device. DICENTIS devices that are powered via a PoE switch, must be powered on with the “Power on” button of the DICENTIS MMD instead. These devices will also power up when the PoE port disables and enables PoE functionality.



Notice!

A system with Multimedia devices only removes the power from the power leads of the DICENTIS cable after the Multimedia devices have powered down. This increases the time to power off the system.



Notice!

DICENTIS Discussion devices that are powered via a PoE switch will always be powered on. These can only be powered on and off by disabling the PoE on the Ethernet port of the PoE switch.

5.2 Manage

This feature is available only for Premium and Ultimate licenses.

Manage is used to manage a meeting. Click the **Manage** button on the main screen to open the manage screen. Initially the manage screen shows a list of all prepared meetings. When there are no prepared meetings, the list is empty. This means that the default meeting is active and a default discussion is open. To access this default discussion, click the green **back to active** button. Refer to *Discussion, page 43*.

Manage meeting means:

- **Activate** and **Deactivate** a meeting. Refer to *Meeting, page 40*.
- **Open** and **Close** a meeting. Refer to *Meeting, page 40*.
- **Manage** the meeting agenda. Refer to *Agenda, page 41*.
- **Manage** voting. Refer to *Voting*.
- **Manage** the discussion. Refer to *Discussion, page 43*.
- **Manage** the menu. Refer to *Menu*.

Preconditions

- The PC from which the meeting application is run, must have meeting rights: **Manage meeting**.
- A meeting has to be prepared before it can be managed. For information on how to prepare a meeting, refer to *Prepare, page 45*.

5.2.1 Meeting

Click the **Manage** button on the main screen to display a list of all prepared meetings. The icon to the left of the meeting number and name shows the status of the meeting:

- **Gray**: The meeting is deactivated.
- **Green**: The meeting is activated.
- **Red**: The meeting is open.

Activate a meeting

- To activate a meeting, press the **Activate** button for the meeting that needs to be activated.
- To show the meeting content without activating or deactivating the meeting, click anywhere in the meeting row.

When the meeting is activated:

- the meeting details screen is opened.
 - On the left, the agenda and the assigned participants are shown.
 - On the right, the meeting details and the agenda are shown.
 - The name of the activated meeting is shown in the header of the meeting application.
- all prepared data of the meeting is sent throughout the system. The data contains names and meeting rights of the participants and the assigned seats.
- a meeting notes file is created. During a meeting, data is saved to this file as applicable. The file is closed once the meeting is deactivated. For more information, refer to *Post-meeting tools*.

If the **Auto Open** function is enabled, the meeting is automatically opened.

When the **Activate** button is not shown:

- the seat to which the PC is assigned to, does not have "**manage meeting**" rights or,
- the user name used to logon to the meeting application is not assigned to the meeting and/or, does not have the "**manage meeting**" rights.

Open the meeting

Click the **Open** button to start the meeting. If the **Auto Start** option is enabled, the first agenda topic is automatically opened.

Close the meeting

To close the meeting, select the meeting on the left, and then click **Close** on the right. The meeting is closed and the meeting list is shown where the meeting can be deactivated.

5.2.2

Agenda

Only a prepared agenda can be managed.

Manage an agenda

1. Make sure the meeting is activated and open.
2. Click **Meeting** in the left-pane.
3. Select the required topic from the left or right pane.
 - The open agenda is shown in the header of the meeting application.
 - The prepared discussion settings and prepared speaker list are sent throughout the system and are activated.
4. To continue with the next agenda topic, just open the next agenda topic in the agenda view.

5.2.3

Participants

- To display a list of participants, click **Participants** in the left-pane: A list of participants is displayed in the right-pane.
- To also view participants in the left pane, click the small triangle next to **Participants**.
- If the participants have images assigned to them, the image is displayed next to their name.
- If the meeting has identification, the following information is displayed at the top of the right-pane:
 - Number of **participants registered**.
 - Number of **participants present**. The presence of a participant is shown by a blue bar; their absence by a grey bar.
 - **Log off all participants** button: Logs off all participants in a meeting. Participants will have to log on again before they can take part in a meeting.
 - **Log off participant** button: Log off a single participant in a meeting by selecting the participant details and the log off button.

5.2.4

Voting

- To hold a prepared voting round:
 - You need an activated Ultimate license.
 - Beforehand, you prepare the meeting with the **Prepare** button on the main screen. For more information, refer to *Voting script, page 57* and *Voting round details, page 57*.
- With an activated Premium license, you can hold a simplified ad hoc round. In this case, enter the details of the voting round during the meeting.

Manage a voting round

1. In the Meeting application, click the **Manage** icon.
2. Make sure the meeting is activated and open.
3. Click the voting icon (tick mark) in the menu button (...) at the bottom right-hand corner of the screen to display:
 - A list of prepared voting rounds (shown on both panes).
 - Total number of **participants authorized to vote** and the number of **participants present** (shown at top of right-pane).
 - The ad-hoc voting fields (the black/grey area at the bottom of the right-pane).
Note: After clicking on another item in the left pane, you can click on **Votings** to redisplay the list of all voting rounds in the right-pane.
4. Either:
 - Hold an ad-hoc voting round by completing the fields **Number**, **Subject**, and **Description**, and then clicking on the **Ready to vote** button, or
 - Open a prepared voting round, by clicking the **Ready to vote** button of a voting round.
5. The voting screen is displayed:
 - The subject of the voting round is displayed at the top of the screen.
 - **Previous** button: Selects the previous voting round.
This button is hidden when:
 - The first voting round in the list is selected.
 - Ad-hoc voting is used.
 - **Next** button: Selects the next voting round.
This button is hidden when:
 - The first voting round in the list is selected.
 - Ad-hoc voting is used.
 - **Recall** button: Recalls the selected voting round. For example, use this button if you selected the incorrect voting round by mistake.
 - **Open** button: Opens the selected voting round.
 - **Close** button: Closes the voting round.
 - **Hold** button: Puts the current voting round on hold. The participants voting buttons are temporarily disabled and votes cannot be changed or cast.
 - **Accept** button: To confirm that the motion is accepted.
 - **Reject** button: To confirm that the motion is rejected. The voting round can be held at another time.
 - **Abort** button: Aborts the current voting round once voting is opened. Voting results are not saved.



Notice!

Only participants with voting rights can vote. The meeting manager gives voting rights to participants.



Notice!

When logged into the Meeting application, a participant with voting rights can take part directly in the voting round.

Voting results

Depending on the installed licenses and system settings, a voting results file is created on the DICENTIS server when a voting round is opened. During a voting round, data is saved to this file as applicable. The voting results file is closed when the voting round is closed. For more information, refer to:

- *Voting round details, page 57* (which explains the voting round settings).
- Post-meeting tools (which gives information on the voting results and meeting results files).

5.2.5

Discussion

This feature is available upon registration, with Premium and Ultimate licenses.

To manage the discussion, click the **back to active** button.

The list on the left shows the discussion list. This list contains **speaking** and **waiting** participants. The following color-coded icons are used:

- **Red** icon: The participant is speaking.
- **Grey** icon: The participant's microphone is muted.
- **Green** icon: The participant is waiting to speak.
- **Yellow** icon: The participant is waiting to respond to the current speaker.

Use the shift button, at the bottom of the discussion list, to shift participants from **waiting** to **speaking**. If the speaker list is full, the longest speaking participant is removed from the speaker list.

Context menu

The discussion list has a context menu to manage the discussion. Right-click the discussion list to show the context menu. The context menu has the following options:

- When an **item** is not selected (i.e. not clicked on):
 - **Stop all speakers and remove all requests:** Stops all speakers and removes all requests.
 - **Remove all requests:** Removes all requests.
 - **Add:** Opens a menu to add a participant to the list, either as a speaker or a waiting participant. Right-click the required participant to add the participant and select **grant the floor** or **add to waiting list**. Depending on the **number of open microphones** and **microphone mode** setting, a participant added to the waiting list might be immediately moved to the speaker list.
- When a **speaking participant** is selected (clicked on), the following option is available:
 - **Stop Speaking:** Stops the selected participant from speaking. Depending on the **number of open microphones** and **microphone mode** setting, the first waiting participant might be immediately shifted to the speaker list.
- When a **waiting participant** is selected (clicked on), the following options are available:
 - **Mute / Unmute:** Mutes or unmutes a microphone input. Is used to temporary mute a speaker. The speaker still remains the active speaker. Only available if **Response mode** is used.
 - **Shift:** Shifts the selected participant from waiting to speaking.
 - **Remove:** Removes the selected waiting participant from the list.

5.2.6

Menu

For more managing options, click the menu button (...) at the bottom right-hand corner of the screen. A pop-up menu with icons will appear. If the menu button (...) is not shown, the **Manage meeting** rights checkbox is not selected in the Seats and Devices screen. For more information, see *Seats and devices, page 71*.

The pop-up menu has the following options:

- **Presentation:** Click the presentation icon, and then click **On** to enable the presentation mode. Click **Off** to disable the presentation mode.
 - The presentation mode is available with Ultimate and Premium licenses.
- **Discussion settings:** Click the discussion settings icon, to open the panel with the discussion setting of the current activated discussion. Changed settings are not stored in the prepared discussion settings of the agenda. You can set:
 - The discussion mode.
 - The speakers list.
 - The priority options.
 - The speech timer when you have an Ultimate or a Premium license.
 - The camera control options. This is an upon registration functionality only.
 - The multimedia device and Meeting Application options.
- **Pan and tilt camera control (PTZ):** Click the pan and tilt camera control icon, and then click **Show** to show the Pan and tilt camera control. Click **Hide** to hide the camera control.
 - The icon is only visible in the discussion screen.
- **Voting:** Click the voting icon to go to the voting screens. The system will either use “basic” voting or “prepared” voting depending on the installed licenses and system settings.
- **Ad hoc voting requirements:**
 - An activated Premium or Ultimate license.
 - The voting function is assigned to the seats in the Meeting application. For more information, refer to *Seats and devices, page 71*.
 - The participants have voting rights.
 - An activated meeting.

Ad hoc voting has the default settings available:

- Answer set
- Majority settings
- Display settings
- Individual/group results
- Total results.

For detailed information, refer to *Voting round details, page 57*.

- **Prepared voting requirements:**
 - An activated Ultimate license.
 - One or more voting rounds have been prepared in the meeting application. For more information, see *Voting script, page 57*.

- The participants have voting rights.
- An activated meeting.

5.3 Prepare

This feature is available only for Premium and Ultimate licenses.

The meeting administrator should use a PC to prepare a meeting. To prepare a meeting, click **Prepare**. This opens the **Prepare** screen.

Prepare meeting means:

- **Administrate Persons.**
- **Add meetings.**
 - Add **Persons** to the meeting.
 - Add **Agenda** topics.
 - Add **Meeting details.**
 - Add a **Voting script** and one or more **Voting rounds.**
- **Discussion profiles** to define the discussion settings.

Preconditions

- The logged on user must have the user right: **Prepare meeting and agenda.**

5.3.1

Persons

To add people/names to the system, click **Persons** in the tree (left pane). Requires system license Premium or Ultimate. **Persons** can be assigned to a meeting, as described in *Participants, page 55*.

The edit icons and a list of persons is displayed in the middle pane. Use the **edit icons** to add or remove persons from the list.

For each person, **General** and **Security** fields can be entered in the right pane:

- **General** fields are:
 - **First name**
 - **Middle name**
 - **Last name**
 - **Title**
 - **Group**
 - **Region**
 - **Country**
 - **Device GUI language:** use the drop-down list to select the required GUI language for the participant's device. If no language is selected here, the language selected on the Rooms page will be used as default.
 - **Headphone language:** use the drop-down list to select the preferred interpretation language. The interpretation language will be automatically selected based on this setting. If the selected language is not available, the floor language will be used.
 - **Email**
 - **Audible beeps:** select this option to hear a 500 Hz beep with 150 milliseconds of duration in the headphone output of the DCNM-DVT. This confirms the vote casting to visual impaired participants.

- **Image:** click **Change** to add a participant picture. Select the picture you want to display for the user and click **Open**. The picture will be displayed in the login screen at **Select from list**, in the participant details in the list of users taking part in a meeting, and in the DICENTIS Webserver if a participant is present. Click **Delete image** to remove the picture.

- **Security** fields are:
 - **User name**
 - **NFC Id:** The number of the Near Field Communication (NFC) tag of the participant. See following sub-heading: “**Configure system for use with NFC tags**”.
 - **Password:** Button for changing the password of a user.
 - **Pin:** Button for changing the PIN code of a user.

Configure system for use with NFC tags



Notice!

NFC tags can only be used with DCNM-MMD2, DCNM-DE, DCNM-DSL, DCNM-DVT and DCNM-FBD2 (with DCNM-FIDP) devices.

If NFC tags are used to identify/authenticate participants, the secretary or clerk should create a unique NFC Id for each participant. To do this:

1. In the **Persons** (middle) pane, click on the name that you want to assign the NFC tag to.
2. In the right-pane, click in the **NFC Id** field to select it.
3. Identify the NFC Id to the system:
 - Make sure a suitable NFC-USB card reader is connected to the USB port of the Client (secretary's) PC. Bosch Security Systems B.V. recommends using one of the following Smart Card Readers: HID Omnikey 5022 CL, HID Omnikey 5421, Identiv SCM PC-Card uTrust 470x F, or Sony USB NFC Reader RC-S380/S.
 - Scan the NFC tag at the USB card reader. The NFC Id will appear in the **NFC Id** field.
 - If you do not have a USB card reader, you can type the NFC Id in the **NFC Id** field instead.
 - If the same NFC card/ID is used for more than one participant, a red border is shown around the **NFC Id field**, indicating that there is a validation error.

Import persons

Instead of entering persons and their related data manually, you can export, edit and import persons to and from an Excel file (XLS). This makes it easier to create and update the personal data in the system.

To create a *template* for the import:

1. Click the left/right arrows button.
2. Create a template file using the **Create template** button.
 - Note:** Do not change the first row or the column headers in the Excel file because this makes the file invalid for importing.
 - Note:** Column headers depend on the language settings in the Meeting application. Make sure the same language is used in the Meeting application for importing and exporting.
3. Close the import / export persons window.

Use this template to enter the data for persons in the proper format.

To *import* persons in the system:

1. Click the left/right arrows button.
2. Click the **Open Excel file** button.
 - Select the Excel file containing the persons you want to import.
 - Note:** The Excel file is checked for validity and any errors are shown. If the file contains errors, fix these in the Excel file and repeat steps 1 to 3. These fields require special attention:
 - User name (check for duplicates): If the user name already exists, the data will be overwritten by the data in the Excel file.
 - NFC Id (check for duplicates): Has to be correctly formatted and must be unique.

- Password: If the field is blank, the same password is retained. To update the password, enter the new password. To remove the password, enter the text <nopassword>.
 - Link to participant image: Enter the path for the picture in the column Picture file or Image file (for example: d:\image\name.png). When you import the file, images will also get updated.
3. Import the list of persons.
Note: The results (both errors and successfully imported data) are shown on the screen below the table listing the persons.
 4. Close the import / export persons window.

To *export* persons:

1. Click the left/right arrows button.
 2. If persons have already been created in the system, use the **Export persons** button to export the current list of persons to an XLS file. You can edit this file in the same way as the template.
- List of fields exported:
 - First name
 - Middle name
 - Last name
 - Title
 - Group
 - Country
 - Region
 - User name
 - Password: this field appears as blank (for security reasons) even though a password was entered in the system. If you leave the field blank, the same password is retained. To update the password, enter the new password.
 - PIN code
 - NFC Id
 - Image file: when exporting the link to the picture on the image server, it will also be placed in the Excel file (https://...../<image>.png). This way, the source file can be traced. If the import file includes a reference to https// before the picture, this will be ignored.
 - Device GUI language
 - Headphone language
 - Email
 - Audible beeps: enter 1 to enable the audible beeps. If this field is empty, no sound will be produced.
3. Close the import / export persons window.

5.3.2

Discussion profiles

Discussion profiles are used to define the discussion settings. Click **Discussion profiles** in the tree. These profiles are used during the preparation of the agenda topics.

Use the **edit icons** to add or remove discussion profiles.

The following can be set:

- **Profile Name:** The name of the profile.

Discussion settings

- **Discussion Mode:**

- **Open (automatic):** When selected, queues in the waiting list are automatically shifted to the speaker list if it is not full yet. If the speakers list is full, a microphone request is queued in the waiting list.
- **Open (manual):** When selected, participants can issue a request to speak and enter the queue. A user using the Meeting Application or a participant with “manage meeting” rights using an MMD or the Synoptic application can grant the participant the floor.
- **Response:** This feature is available only for Premium or Ultimate licenses. When selected, participants can issue a request to speak and enter the queue (green icon).
Participants can also issue a request to respond to enter the queue and respond to the active speaker (yellow icon).
A user using the Meeting Application or a participant with “manage meeting” rights using an MMD or the Synoptic application can grant the participant the floor. When the next participant in the speakers queue (green icon) is granted the floor, the response queue (yellow icon) will be cleared, since the speaker to which they want to respond no longer has the floor.
Only 1 active speaker and 1 active responder can have the floor. They can temporary mute their microphone during the discussion and activate it again using the microphone button. While muted, the microphone LED is off, but the microphone button LED is on.
A request to respond can only be issued on a Multimedia device and Discussion device with touchscreen, using the yellow button on the touchscreen.
- **First in first out:** When selected, participants can control their own microphone. If the speakers list is full, a microphone request overrides the longest speaking participant.
- **Voice activated:** When selected:
 - the microphone buttons on the discussion devices are colored red.
 - the microphone is activated when a participant speaks.
 - participants do not need to press the microphone button to get the floor.
 - the microphone button can be held in order to temporarily mute the microphone.
 - the discussion list is cleared and is not updated while voice mode is active.
 - the chairperson can still use the priority button to override all participants.
 - camera control is not available.

This mode can be used for systems with up to 50 devices. It can be configured in the profile and agendas during a discussion.
If a microphone has VIP rights (refer to *Participants*, page 55), it will not be automatically activated when the participant speaks. Instead a participant with VIP rights has to press the microphone button to speak.

You can extend the **Voice activated** mode with the Ultimate license to display the participant speaking at the moment. With this license, you can check the **Show active microphone** box to show automatically the participant speaking in the speaker list. This will make it possible to direct a camera to the speaker. The Conference protocol and the .NET API will contain who has the floor. From here, external applications, such as audio and video recording, can use this data.



Notice!

This functionality is designed for applications where each participant uses an individual device. Otherwise, the system does not know who is speaking. Do not use this functionality in rooms with high ambient noise or which are very reverberant.

The DICENTIS system uses its Dynamic Channel Allocation (DCA) technology to sense all microphones continuously in order to:

- Quickly open the microphones if audio is detected to prevent missing syllables.
- Reduce the number of open microphones to prevent noise for optimum speech intelligibility.

The DCA algorithm keeps the microphone open for 2 seconds for optimum performance. Due to its continuous sensing of the audio, it can happen that one microphone is shown in the speaker list even though nobody is speaking.

- Once you have checked the **Show active microphone** box, you can:
 - Use the **Attack time** slider to set the minimal audio duration. The minimal audio duration prevents short audio spikes, like coughing, from placing the participant in the speaker list. The attack time sets how long the audio needs to be before it is regarded as speech. The default recommended is 2000 ms. The minimum is 0 ms. The maximum is 10 000 ms.
 - Use the **Release time** slider to set the duration the microphone stays on after the audio level becomes too low. The default is 500 ms. The minimum is 0 ms. The maximum is 10 000 ms.
 - Check the **Show active by red mic LED** checkbox to light up the red microphone LED when the participant is in the speaker list.
 - Configure the number of speakers displayed in the speaker list in **Max active microphones**. One is the recommended value.
- **Speakers list:**
 - **Max active microphones:** The maximum number of active microphones in the speakers list can be pre-selected (max. 25). Disabled when **Voice mode** or **Response** is used.
 - **Allow speaker to mute mic:** When selected (default), the participant can use the left microphone button to temporarily mute the microphone. If disabled, the left microphone button behaves the same as the right microphone button.
 - **Allow speaker to switch mic off:** When selected, participants are allowed to switch off their microphone. Disabled when **Open (automatic)**, **First in first out** or **Voice mode** is used.
 - **Switch mic off after 30 sec of silence:** This function can be used when participants forget to switch-off the microphone manually. Disabled when **Voice mode** or **Response** is used.
 - **Ambient microphone:** When selected, the ambient microphone connected to input 1 is enabled.
 - **Speakers queue size:** The maximum number of requests in the waiting list. A maximum of 200 requests can be selected. Disabled when **First in first out** or **Voice mode** is used.
 - **Allow request to speak:** When selected, request-to-speak is allowed. Disabled when **Open (automatic)**, **First in first out** or **Voice mode** is used.
 - **Allow cancel request to speak:** When selected, participants are allowed to cancel their request-to-speak. Disabled when **Open (automatic)**, **First in first out** or **Voice mode** is used.
 - **Responders queue size:** The maximum number or requests in the response queue. A maximum of 99 can be selected. Only available if **Response mode** is used.

- **Allow cancel request-to-respond.** When selected, participants are allowed to cancel their request-to-respond. Only available if **Response mode** is used.
- **Show waiting in queue by green mic LED:** When selected, the LED in the microphone will be on for devices in the queue (instead of off when not selected). Disabled when **First in first out** or **Voice mode** is used.
- **Show first in queue by blinking green LED:** When selected the microphone button and the microphone LED will blink green for the first person in the queue. Can only be used when **Show waiting in queue by green mic LED** is also selected. Disabled when **First in first out** or **Voice mode** is used.
- **Show queue for participants:** When enabled, the queue will be displayed on all seats. When disabled, it will only be displayed on seats which have Manage meeting or VIP rights. This allows you to show the queue to the chairperson and operator, but hide it for all other participants. This functionality is also available for the synoptic layout so that the queue is shown to the chairperson and operator, but hidden for participants. Disabled when **First in first out** or **Voice mode** is used.
- **Priority options:**
 - **Priority tone:** When selected, a priority tone is audible when priority is used. Set to on by default. The priority tone can be configured per agenda item or during the discussion, but can only be used if a priority tone was defined.
 - **Mute all speakers:** When selected, it mutes all speakers temporarily when priority is used.
 - **Switch off microphones and clear queue:** When selected, all speakers and persons in the waiting list are cancelled when the priority is used.
- **Speech timer:**
 - **Speech time per speaking turn:** When selected, the speech timer can be set per speaking turn in minutes and seconds to a maximum of 99 minutes. Each time a speaker is allowed to speak, this time is awarded.
 - **Show last minute by red blinking mic button:** When selected, the microphone button on the active speaker's device will start blinking when the last minute of speech time has been reached.
 - **Show last minute by red blinking mic LED:** When selected, the microphone LED on the active speaker's device will start blinking when the last minute of speech time has been reached.
 - **Adjust speech time:** When selected, the speech time can be increased or decreased with the number of minutes and seconds entered by clicking the + / - icons at the top of the Discussion profiles screen.
 - **Turn microphone off when time has elapsed:** When selected, the microphone is switched off after the set speech time has elapsed. When not selected, the microphone will stay open after the set speech time has elapsed.
- **Camera control options** (This feature is available only upon registration, not for Premium or Ultimate licenses):
 - **Camera control:** When selected, activates external or SDI video switchers, as required; directs the cameras towards the required pre-configured positions; displays the camera image on the multimedia devices.
 - **Camera override:** When selected, the last participant that activated their microphone is shown.
- **Multimedia device and meeting application options:**

The available options depend on the installed licenses and the settings in the Discussion profile.

- Upon registration only:
 - **Camera control options** are available.
 - **Display video on device**: When selected, and **Camera control** is selected, the active speaker or overview camera will be displayed in the camera view in the Meeting Application and on the multimedia devices.
 - **Display logo**: If **Camera control** is not selected, the customer logo or a blank background is displayed in the Meeting Application and on the multimedia devices.
- With Premium and Ultimate licenses:
 - If both **Camera control** and **Camera override** are selected in the **Camera control options**:
 - **Display video on device**: When selected, and **Camera control** is selected, the active speaker or overview camera will be displayed in the camera view in the Meeting Application and on the multimedia devices.
 - **Display image of speaker**: When selected, the server controls the video switcher and the cameras. The latest speaker is displayed in the Meeting Application and on the multimedia devices.
 - **Display image of newest speaker**: When selected, the image of the latest speaker is shown in the Meeting Application and on the multimedia devices.
 - If **Camera control** is not selected in the **Camera control options**:
 - **Camera override** becomes disabled and **Display logo** is activated. The company logo is shown in the Meeting Application and on the multimedia devices.



Notice!

If a profile is changed, the agenda items that use this profile are not automatically updated. Therefore, after updating a profile you will have to reapply this profile to all agenda items that require the new settings.

5.3.3

Meetings

To prepare a meeting:

- Use the **edit icons** to add or remove a meeting.
- When a new meeting is added, the **Meeting details** can be entered.
- Use the **copy icon** to copy a meeting, including all meeting details.
- Use the **A-button** to prepare a meeting with language selection without the need to create persons and assign them to seats.

How does the A-button work

This button is active if:

- You have a license that enables you to create meetings
- The system is powered on so it can retrieve the devices assigned to seats
- The seat names are unique

By pressing this button, the system creates persons with the same user names and last names as the seat names. The persons are assigned to the seats whose seat names correspond to their user names and granted with the rights defined at the respective seats. If you use this button to prepare a meeting, the options **Automatically start this meeting upon powering up the system** and **Automatically open meeting on activate and deactivate on close meeting** are enabled for that meeting.

Note: If you create a user who is neither a person nor part of the participant group and has the same user name as a seat name, the respective seat remains empty and has no language selection or voting rights. Only persons can be assigned to seats.

5.3.4

Meeting details

Click meetings in the tree to display the list of meetings.

- **Name:** Type the name of the meeting.
- **Copy link:** Copy the meeting link to send to a participant joining remotely. The remote participants can join via a web browser on a tablet or computer. They log in using the user name and password defined in the **Security** fields. Refer to *Persons*, page 45. To find out which licenses allow participants to join remotely, refer to the *License overview*, page 20.
- **Description:** Enter a suitable description.
- **Start Date/Time:** Select the required start date and time of the meeting.
- **End Date/Time:** Select the required end date and time of the meeting.
- **URL:** Enter a suitable URL, as described in *Uploading and accessing files*, page 144. Enables documents stored on the **DcnmMeetingDocuments** website to be displayed when the blue **More info** hyperlink on the multimedia device is pressed.
- **Automatically start this meeting upon powering up the system:** Select the checkbox to automatically start the meeting upon powering up the system or the DICENTIS server. This action is not executed when a meeting is already active.
- **Automatically open the meeting after the meeting is activated:** Select the checkbox to automatically open the meeting once the meeting is activated.
- **Automatically start the agenda when the meeting is opened:** Select the checkbox to automatically start the agenda when the meeting is opened.
- **Identification:** When selected, meeting participants are requested to identify themselves. Only seats that have an identification license participate in the identification process. Select the required option:
 - **Participant can only log in at assigned seat:** Participants can only log in to the seat that has been assigned to them during the preparation of the meeting. The option can be combined with the Identification and Verification options. If no Identification and Verification options have been set, the welcome screen is shown with the participant's name and a log in button to confirm their identity at that seat (multimedia and DCNM-DE only).

Note: When **Participant can only log in at assigned seat** is enabled, devices that have identification and do not have a person assigned to them show the blocked screen.
 - **Identify participant at seat by:**
 - **Swipe NFC card:** Participants can use an NFC card to identify themselves (DCNM-MMD2, DCNM-DE , DCNM-DSL and DCNM-DVT). To use this option, the system must be configured for use with NFC tags. See *Persons*, page 45.
 - **Keep NFC card at device:** Participants can use an NFC card to identify themselves (DCNM-MMD2, DCNM-DE , DCNM-DSL and DCNM-DVT). As long as the NFC card is in the range of the NFC reader, the participant remains logged in. When the participant moves the card outside the range of the NFC reader, the participant is logged out. To use this option, the system must be configured for use with NFC tags, see *Persons*, page 45. The **Keep NFC card at device** option cannot be used in combination with dual use, see **Dual Use** option in *Seats and devices*, page 71.

- **User name:** Participants enter their user name to confirm their identity (multimedia device only).
- **Select from list:** Participants can select their name from a list of participants (displayed on the screen line) to confirm their identity (multimedia device only).
- **External system:** Participants are identified by means of an external system (all DICENTIS devices).

Note: When identification is done via an external system, verification is also only possible via an external system.

- **Verify participant at seat by:**
 - **PIN code:** Participants can use a PIN code to authenticate themselves (multimedia device and DCNM-DE only).
 - **Password:** Participants use their password to authenticate themselves (multimedia device only).
 - **External system:** Participants are authenticated by means of an external system (all DICENTIS devices).



Notice!

Remote participants can log in regardless of the selected identification mode. If no identification mode is selected and a remote participant is assigned to a seat in the meeting room, that participant is considered to be already seated and cannot join remotely. To prevent this situation, always select an identification mode or do not assign remote participants to seats in the meeting room.

Quorum

- **Quorum:** Quorum is used to validate if enough participants are present to continue the meeting or voting round. When enabled, it will be automatically calculated if the expression results in a true or false. The expression information is available on the Meeting application, Synoptic control, .NET API and Conference protocol.
 - **Use vote weight:** When selected, the configured vote weight will be used for the automatic quorum calculation (e.g. if a participant has a vote weight of 5, his presence will be calculated as the presence of 5 participants).
 - **Quorum expression:** Use the buttons in the table to the right to insert the variables into the Quorum expression, or type the variables in the expression fields.
 - **Test result:** The test values can be used to validate the expression. The test result box colors turns green when the expression is true; red when the expression is false; and orange when the expression is invalid.
- Example:** if at least 2/3 of the participants with voting rights need to be present to reach the quorum, then the Quorum expression will be:
 $\text{PresentVoteRights} / \text{VoteRights} \geq 2/3$

Note: the **Quorum** is displayed in the Meeting application and Synoptic control as a bar graph. For correct display, the value should be between **0** and **1** and **>** or **≥** must be used. If these prerequisites are not met, then a bar graph cannot be displayed and only the true or false indication will be displayed, based on the expression.

5.3.5

Participants

Persons can be added to and removed from a meeting by using the **Add** and **Remove** buttons in the **Participants** pane. As soon as a **Person** is added to a Meeting that person becomes a **Participant**.

Persons are added to the system as described in *Persons, page 45*.

The number of participants that can attend a meeting is determined by the available participant licenses. While it is feasible to include additional participants in the meeting, the maximum number that can join is limited by the number of participant licenses assigned. The system provides feedback regarding the allowed number of participants for a specific meeting, based on the assigned license count.

Button	Description
Add	Used to add Persons to a meeting.
Remove	Removes the selected participant from the list.

Table 5.1: Button function

- **Discuss:** When selected, the participant is allowed to discuss.
- **VIP:** Can be used to grant viewing rights for the voting results (interim-hold-closed results) to special persons and/or seats. The way the voting results are displayed is determined by the settings in **Vote settings, Results**. See *Voting round details, page 57*. Participants/seats with VIP rights can also view the waiting queue if the option **Show queue for participants** is disabled in the Discussion settings. See Discussion profiles.
- **Vote:** When selected, the participant is allowed to vote. The number of participants with voting authorization is shown in between brackets in the column header, so you can check if all required participants have voting authorization.
- **Vote weight:** Allows you to configure the vote weight of a participant. The value in between brackets in the column header is the sum of all vote weights of the participants with voting authorization. See also *Voting round details, page 57*.
- **Manage meeting:** When selected, the participant is allowed to manage the meeting (DCNM-MMD2, Meeting application, or DICENTIS Webserver synoptic control).
- **Priority:** When selected, the participant is able to use the priority button.
- **Vip type:** Assigns additional microphone authorizations to the participant, independent of the microphone mode and numbers of open microphones (use the small triangle and drop-down list to select a Vip type):
 - **Button Operated:** The microphone will always be activated when the microphone button is pressed. This is the default setting for a chairperson.
 - **Ptt Operated:** Push to talk. The microphone will always be activated when the microphone button is pressed and held in. This is the default setting for a discussion device that is used as an interruption microphone.
- **Seat name:** Assigns a participant to the selected seat name. Use the small triangle and drop-down list to select a seat name.
- **Screen Line:** Displays the text/name which will be visible. The Screen Line is configured in **Configure > Rooms**. See *Rooms, page 63*.

**Notice!**

Do not assign a participant to the Meeting application seat, because this could be confusing for the user. The meeting application has a login screen that the user should use to log into the system.

5.3.6**Agenda**

An Agenda, which is part of every meeting, can have one or more topics.

- Use the **edit icons** to add or remove a topic.
- Use the **arrow buttons** to change the order of the topics.
- Use the **copy icon** to copy an Agenda.
- To prepare a topic, select the new topic in the tree, and enter the required information, as described in:
 - *Topic details, page 56*
 - *Participant List, page 56*
 - *Speaker waiting list, page 57*

**Notice!**

The items in the top bar of the agenda pane, Subject, Description, URL, and Discussion Settings can be hidden and displayed by right-clicking on one of the items and then selecting or deselecting the required item.

5.3.7**Topic details**

The following information can be defined for an agenda topic:

- **Subject:** Enter a suitable subject
- **Description:** Enter a suitable description
- **URL:** Enter a suitable URL, as described in *Uploading and accessing files, page 144*. Enables documents to be displayed when the blue **More info** hyperlink on the multimedia device is pressed (DCNM-MMD2 only). These documents can be stored on the customer's website
- **Discussion settings:**
 - Select the required profile from the drop-down list.
 - Click the text in the drop-down list. The discussion setting of the agenda topic will open. Make your settings, and optionally save them as a new profile.
 - See also: Discussion templates.

**Notice!**

As the discussion settings are defined in a profile, a local copy of the discussion settings is made and stored in the agenda topic. This means, that after a profile has been selected in an agenda topic, the discussion settings of an agenda topic are not updated when a profile is changed.

5.3.8**Participant List**

All Participants that are assigned to the meeting can be selected and added to the **Speaker waiting list**.

- Use the **Add** button to add the selected **Participant** to the **Speaker waiting list**.

- The **Filter by** text box can be used to narrow the search, for example **Participant** names.

5.3.9 Speaker waiting list

The **Speaker waiting list** is used to set up the sequence of the **Participants** who are planned to speak during the agenda topic.

- Use the **arrow buttons** to change the order.
- Use the **Remove** button to remove the selected **Participant** from the **Speaker waiting list**. This participant will stay a Participant in this meeting.

5.3.10 Voting script

This feature is available only for Ultimate licenses.

A Voting script, which can have one or more voting rounds, can be added to a meeting. Use the following procedure to add a voting round to a Voting script:

1. In the tree, click on **Voting script**.
2. In the right pane, click on a row.
3. At the top of the page:
 - Use the **blue plus** icon to create an empty voting round (all settings have to be manually updated).
 - Use the **blue minus** icon to delete a selected voting round.
Note: To delete multiple voting rounds, use **Shift** + left mouse click to select the voting rounds, and then click the **red cross**.
 - Use the **duplicate** icon to create a new voting round, based on the settings of the selected voting round.
 - Use the **up/down** arrows to change the order of a selected voting round.
4. To prepare a voting round, select the voting round in the tree, and then enter the required information, as described in *Voting round details, page 57*.

5.3.11 Voting round details

The following information can be defined for a voting round.

Number: For entering the reference number of the voting round.

Subject: For entering the subject of the voting round.

Description: For entering a short description of the voting round.

URL: Enables documents stored on the **DcnmMeetingDocuments** website to be displayed when the blue **More info** hyperlink on the multimedia device is pressed (multimedia device only).

Vote settings

Answer set:

Drop-down list with options for:

- **Yes/Abstain**
- **Yes/No**
- **Yes/No/Abstain**
- **Yes/No/Abstain/DNPV**
- **For/Abstain**
- **For/Against**
- **For/Against/Abstain**
- **For/Against/Abstain/DNPV**
- **A/B**

- **A/B/C**
- **A/B/C/D**

**Notice!**

DNPV (Do Not Participate in the Vote). This option allows participants to indicate that they do not want to participate in the vote.

**Notice!**

The DCNM-DVT and DCNM-FVP do not display the letters A, B, C and D. On these devices, the letters are represented by colors:

- A - Green
- B - Red
- C - Yellow
- D - Orange

Buttons:

- **Hide answer buttons after casting vote:** When selected, the answer buttons will not show the cast vote on the device. This prevents influencing other participants and keeps the voting process as anonymous as possible, when used in combination with not showing or storing individual results. Total and individual results can still be saved on the DICENTIS server, depending on the settings in **Store results**.
- **Vote can be changed after casting:** This option is selected by default and enables the participants to change their vote after casting it. If you deselect this option, the participants are no longer able to change their vote after casting it.
- **Cast vote if no vote is cast upon closing of the voting round:** When selected, this option enables you to configure which answer is automatically cast by participants who are present in a meeting or press the present button but do not cast a vote until the voting round is closed. You can choose the voting option you want to be automatically cast by those participants from a dropdown list. The default value of the field is *Abstain* or the last voting option of the answer set you selected if *Abstain* is not available. To prevent mistakes, this option is disabled if you change the answer set.

Voting timer:

For defining a time for a voting round. The voting time is displayed on the multimedia devices and in the voting screen of the Meeting application (DCNM-MMD2 only).

The voting timer has radio buttons options for:

- **No voting timer:** When selected the voting timer is not used, and the voting timer **Duration** box is hidden.
- **Keep voting round open when time is reached:** When selected, the voting round is kept open when the voting time has expired. Participants can still cast or change their vote. The additional time is shown as a negative value. For example, if a voting time was set for 30 seconds (00:30), -00:30 will be displayed after one minute. When the voting timer has reached -9:59, it will stop counting down, but the vote remains open until it is closed manually.
- **Hold voting round when time is reached:** When selected, the voting round is put on hold when the voting time has expired. The voting round can be resumed and put on hold as required. The additional time is shown as a negative value. Participants can still cast or change their vote.

- **Close voting round when time is reached:** When selected, the voting round is closed when the voting time has expired. Participants can no longer cast or change their votes. Voting must take place within the specified time.
- **Duration:** For entering a value for the voting timer. Use the **up/down** arrows to select the time in minutes and seconds.

Majority:

- **Present button:** When selected, participants have to press the **Present** button before they can vote. Enable this setting together with entering the **Present** variable in the denominator when the 100% needs to be all people who have pressed the **Present** button. They do not actually have to have voted, having pressed the Present button is sufficient.
 - **Use vote weight:** When selected, the vote weight can be configured for every participant during a meeting. This enables participants to vote for other persons who are absent from the meeting (proxy voting). The weight of the vote is determined by the number selected or entered in **Vote weight**. The total number of votes is shown in brackets after **Vote weight**. For example, when there are 7 participants in a meeting and one of these has a vote weight of 2, the total number of votes will be 8. Vote weighing is possible for all voting types (Secret, Open, and so on) and is displayed in the API-results, the meeting results XML file and the voting results XML file.
 - **Majority calculation:** When enabled, it will be automatically calculated if the expression results in a true or false. The expression information is available on the Meeting application, Synoptic control, .NET API and Conference protocol.
 - **Majority expression:** Use the buttons in the table to the right to insert the variables into the **In favour** and **100% setting** fields, or type the variables in the expression fields.
 - **Test result:** The test values can be used to validate the expression. The test result box colors turns green when the expression is true; red when the expression is false; and orange when the expression is invalid.
- Example:** if more than half of the participants with voting rights need to vote in favor to reach the majority, then the Majority expression will be:
- Yes / VoteRights > 0.5*

Note: the **Majority** is displayed in the Meeting application and Synoptic control as a bar graph. For correct display, the value should be between **0** and **1** and **>** or **≥** must be used. If these prerequisites are not met, then a bar graph cannot be displayed and only the true or false indication will be displayed, based on the expression.

Results:

To differentiate between the viewing rights for different participants, the settings for individual, group and total results can be applied to participants, participants with VIP viewing rights, and participants with manage meeting rights.

The settings can also be applied to external systems that use the API (Meeting application, Synoptic control and custom-built applications using the API).

- **Set results for:**
 - **Open voting round:** To configure an 'open voting' round ('open voting' is sometimes referred to as 'public voting'), where individual results are available. When selected, data from the individual voting rounds is saved in xml files on the

- DICENTIS server and passed on via the API to external systems (including the Meeting application and Synoptic control). For more information see, Voting results file.
- **Secret voting round:** To configure a secret voting round, where individual results are NOT available. When selected, the cast vote is hidden. Individual results are not displayed on the multimedia devices, Meeting application, or API, and CANNOT be retrieved from the DICENTIS server or via the API.
 - **Display results:**
 - **Individual vote is cast:** This setting shows which participant has cast a vote, but not what he has cast.
 - **Display individual and group results:** This setting show the individual and group results.
 - **Total cast votes:** This setting show the number of cast votes, but not what was cast.
 - **Display total results:** This setting shows the total results.
 - **Display majority:** This setting shows the majority status.
 - **Selection:**
 - **Always:** The results are always displayed.
 - **On hold/closed:** The results are displayed on hold/closed.
 - **On accepted/rejected:** The results are displayed when the vote has been accepted or rejected.
 - **Never:** The results are never displayed.



Notice!

Individual and group results are never displayed on the multimedia and discussion devices, nor in the Meeting application. Individual results can be viewed by a participant logging in to Synoptic control if one or more of the above options has been selected.



Notice!

When a participant logs into the DICENTIS Webserver, both the configuration rules for the external system and the participant are applied. Applied first are the limitations (settings) for the external system, and, secondly, the limitations (settings) for the participant.

Example:

If **Display individual and group results to an external system** is set to **On hold/closed** and **Display individual and group results to participants** is set to **Always**, it will display the results of On hold/closed, because the interim results are not passed on to the API.

- **Store results:** Determines how results are dealt with on the DICENTIS server.
 - **Individual and totals:** Individual and total results are stored.
 - **Only totals:** Only total results are stored.
 - **Do not store totals:** No results are stored.

Note: A voting round is secret when these criteria are met:

1. **Display Individual and group results for participants**, select **Never**.
2. **Display Individual and group results for VIP**, select **Never**.
3. **Display Individual and group results for Participant with manage meeting**, select **Never**.
4. **Store results**, select **Only totals**, or **Do not store results**.

In all other situations, the voting round is open.

Save settings as default button: Saves the **Vote settings** of the selected voting round as the default for creating a new voting round.



Notice!

The Save settings as default feature can be helpful if you want to create multiple voting rounds that have the same Vote settings.

- Use the button like this:
 - Select the voting round you want to reuse, by clicking the green icon in the tree.
 - Click the **Save settings as default** button.
 - Click **Voting script**, and then use the 'plus' icon to create a new voting round with your favorite settings.

5.3.12

Voting settings

This feature is available only for Premium and Ultimate licenses.

Configure the default voting options in the **Voting settings** page.

These settings are used:

- When a new voting round is created
- When an ad-hoc voting round starts.

For more information, refer to the **Vote settings** section in *Voting round details*, page 57.

5.3.13

Prepare interpretation

This feature is available only for Ultimate licenses.

The secretary can configure interpreter desks remotely before and during a meeting using the Meeting application or the API. These meeting settings should be configured for interpretation:

- The languages needed in the meeting (from the configured language list the Meeting application); applies to all booths.
- Assign the languages to the DICENTIS Interpreter desks or external inputs.
- Configure the interpreter desks A, B and C outputs.
- Configure the auto-relay booths.

Configuration steps:

1. Open **Prepare > Meetings**.
2. Select the meeting you want to configure the interpreting settings for and open the **Meeting details**.
3. Select **Interpreting**.
4. **Use default room settings** is enabled by default. If you want to use the default settings for a meeting (configured via **Configure > Rooms**), leave the setting as is.
5. If you do not want to use the default settings for a meeting, uncheck **Use default room settings**. Here you can define the language and desk assignment settings for this meeting:
 - **Language selection**. Here you can select the available languages for the meeting (from the defined languages list), change the order and appearance of the languages and their source (DICENTIS, DCN NG / Dante gateway, or Dante™). See *Language selection*, page 76 for a detailed description of the options.
 - **Interpreter seats**. Here the following information is shown: Booth, Desk, Status, Device info, selected A, B and C output, and selected headphones is shown. To change these settings, select one or more lines and click **Edit**. The **Desk and Booth**

settings pane appears. If you selected multiple lines “Booth: Multiple” and “Desk: Multiple” is shown to indicate that the settings apply to more than one booth/desk. See *Interpreter desks*, page 79 for a detailed description of the options.

Hint: The configuration settings from **Rooms** are stored on the desks. Since the output languages may differ from those configured at **Rooms**, it is likely you will have to configure the output languages for the desk again. You can easily do this selecting *all desks* and clicking the **Auto Configure** button.

Note: If a desk shows the languages on the A/B/C output without a number, these languages are not included in the meeting. If the A output has no language that is included in the meeting, the desk is disabled.

6. Click **Apply** to keep the settings, or **Discard** to cancel them.

5.4 Configure

Configure is used to set up and configure the system. To start configuration on the main screen, click **Configure**. This opens the **Configure** screen. Use the tree in the left pane to navigate this screen. Click the small triangle to open the menu items in the tree.

Configure means:

- Add **User groups**.
- Add/modify/delete **Users** information.
- Define **Rooms**.

Preconditions

- The user logged on needs to have the user right **Configure system**.

5.4.1 User groups

User groups can only be defined if you have the necessary rights. Different types of **User groups** can be created by defining privileges for each user group. Examples of **User groups** are; secretary, operators, etc.

- To add, remove or copy **User groups**, use the **edit icons**.
- **Access Rights:** Per **User group** several options can be selected.
- **Authentication:** Per User group **Windows Authentication** can be selected. When enabled, the user name and password will be validated against the data in the Windows Authentication server. When disabled, the password will be checked against the password that is stored in the **DICENTIS Meeting application**.

When **Windows Authentication** is used, the PC running the DICENTIS services and the MMDs must be able to access the Windows Authentication server. The user name has to be used in combination with the domain, for example, *USA\Bill* where *USA* is the name of the domain and *Bill* is the user name of the user.

5.4.2 Users

To add **Users** that should logon to the system, click **Users** in the tree. Here the **Users** are listed. To add or remove **Users**, use the edit icons.

For each **User:** **General** and **Security** fields can be entered:

- **General** fields are for example, name, title, country.

- **Security** fields are used to be able to log in to the Meeting Application, the Multimedia devices, and the Participant Application (if a participant uses the temporary seat assignment).

5.4.3

Languages

The predefined languages in the Meeting Application cannot be removed. However, you can add or remove your own (custom) languages and set the sorting order that is used to show the languages during meeting preparation.

To add custom languages:

1. Navigate to **Configure > Languages**.
2. Click the plus sign to add a new language. A blank row is inserted in the list.
3. Enter a number in **Sorting order**, for example 26. The sorting order number of the languages can be changed. This helps the Technician with easier configuration of the language setup. Refer to *Language selection, page 76*.
4. Enter a name for the **Language**, for example Swahili. This is used as a general description.
5. Enter the **Original name** for the language. For example, Swahili can be displayed as Kiswahili.
6. Enter an **Abbreviation** for the language. For example, SWA. If Swahili is assigned to OMI output-2 it can be displayed as: 26 Kiswahili (so number and language name in the original language) on the discussion and multimedia devices.
7. The **Short abbreviation** displays the official 2 letter code for the language.
8. Enter an optional **User defined** abbreviation. For example, the official abbreviation for German is “DE”, but you can enter “GER” as user defined abbreviation. If no user defined abbreviation is entered, **No** will be shown.

The way the language is displayed depends on the setting selected under **Language > Language is displayed on device as**.

To remove a custom language, select the row you want to delete and click the minus sign.

5.4.4

Rooms

Rooms contain all settings related to the room.

To change the room details, the user right **Configure system** is needed.

Room details

- **Automatic seat assignment:** When selected, a new device connected to the system is automatically assigned to a seat.
Uncheck the **Automatic seat assignment** checkbox after you have configured the system. This gives you more control over your system with respect to replacing devices and adding seats.
- **Participant’s device GUI language:** Use the drop-down list to select the required GUI language of all devices with a graphical user interface. This setting is overruled by the GUI language setting in the **Persons** page.
- **ScreenLine definition:** The screen line is defined here. To activate the screen line, click the **Apply** button. Insert here the information entered in the general fields of a Person or User (that is: FirstName, LastName, MiddleName, Title, Region, Country) by using the \$-sign directly in front of the description.
Screenline definition example: \$FirstName \$LastName \$MiddleName \$Title \$Region \$Country

Optionally, limit the number of characters of an item shown from 1 to 99 by adding the number behind the field between parentheses. Numbers used below 1 or above 99 are parsed as normal text. The screen line entry must contain at least one of the above items. If the entry is not accepted, it is enclosed within a red box.

- **Meeting notes location:** The location of the meeting notes is defined here. By default, the meeting notes are saved on the Server PC in: **\ProgramData\Bosch\DICENTIS**. Use the **Browse** button to select another location, if required. For more information on the meeting notes, refer to *DICENTIS Webserver*, page 91.
- **Power off devices when system is idle for:** Select this function to automatically turn off the participant devices and interpreter desks when the system is idle for a certain amount of time to save energy and increase the lifetime of the equipment.
Note: The system is regarded as being in idle state when the speakers list (or queue) is empty and when no microphone of a DICENTIS interpreter desk is active. This mode is disabled when microphone mode **Voice** is used.
Note: This option turns off the system by disabling the 48 V on the high power outputs of the DICENTIS (Audio processor and) Powering switch.



Notice!

Discussion devices and interpreter desks connected to PoE switches will not power off.

The participant devices and interpreter desks can be powered on using the available methods:

- The power on functionality on the Meeting Application.
- The power on functionality on the Synoptic Control.
- The power on functionality on the multimedia device connected to the low power/always powered DICENTIS output of the DCNM-APS2/DCNM-PS2 (or DCNM-APS/DCNM-PS).
- Making a physical power on button based on the circuit-diagram described in chapter 5.5.5 of the DICENTIS Installation manual.

This function is enabled by default on new systems and after upgrading the system software to the 3.2 version.

- **Room name:** Enter the name of the Room to easily distinguish it from the other DICENTIS systems. You can configure the name as needed. Afterwards, it will be displayed in:
 - The Meeting application.
 - The .Net API.
 - The DICENTIS Webserver.
 - The Conference protocol.
 - The meeting and voting notes.
- **Room contact email:** for future releases.
- **HTTP proxy devices:**
 - **Proxy address:** Address (IP address or host name) of the host running the proxy server.
 - **Proxy port:** Port number of the host running the proxy server. This is the port at which the proxy server will listen to clients.
- **Image server info:**

- **Image server url:** Address (IP address or host name) of the host running the image server. This is by default the same PC the DICENTIS Meeting Application is installed on. To avoid performance and/or space issues you can install the image server on a different computer. Refer to *Installing the image server on a different computer, page 143*.
- **Test image server connection** button: Used to test if the image server connection is working. If the configuration is working properly, the message '**Successful**' is displayed. This is especially useful if the image server has been moved to a different PC.



Notice!

Enabling **Display image of newest speaker** in **Discussion profiles** creates a high CPU load on the DICENTIS server if the system has more than 500 Multimedia devices. To prevent this, use a separate image server to reduce the load on the DICENTIS server.

- **Customer logo:** Click **Change** to select a logo (e.g. your company logo) that will be displayed:
 - In the login screen of the multimedia device (DCNM-MMD and DCNM-MMD2).
 - In the login screen of the discussion device with touchscreen (DCNM-DE).
 - In the home screen of the multimedia device (DCNM-MMD and DCNM-MMD2).
 - Behind the speakers list on the discussion device with touchscreen (DCNM-DE).
 - In the home screen and in the camera view of the Meeting application.
 - In the camera view of the multimedia device (DCNM-MMD and DCNM-MMD2) if no camera has been configured or if **Display video on device** is not selected under **Prepare > Discussion profiles > Speaker Viewing Options**. Refer to *Meetings, page 52*.

Note:

- The recommended size of the logo image is 1024 X 600 px. The resolution of the multimedia device (DCNM-MMD and DCNM-MMD2) screen is 1024 x 600. The resolution of the discussion device with touchscreen (DCNM-DE) screen is 480 x 272.
- It is recommended that the selected logo is plain at the corners, because the image will be cropped by 150 px at each end to display the image on the camera view.
- It is recommended to use images with dark, preferably black background for optimum readability of texts. Do not use white or light backgrounds, because the text will not be readable.
- The image will automatically be scaled vertically to fit the camera view window (a small part from the left side and right side will be cut off) if the aspect ratio is different from 1024 X 600 px.

5.4.5

Audio settings

- **Audio tones:** Use the **Set...** and **Remove** buttons to upload and remove custom chimes for **Summon** and **Priority**.
Audio file specification:
 - PCM format.
 - 16 bits per sample.
 - 48 k sample rate.
 - Mono.
 - Max 700 kb file size.

- **Audio tones audible on headphones:** When selected, the audio tones are sent to the headphones of the participants and interpreters and **Out 2** when configured as **Recorder (Int. floor)**. **Off** by default.
- **Mic:** Shows the signal of the microphones when they are being spoken in.
- **System:**
 - **Master volume:** Master volume to control the devices' loudspeakers and the sound reinforcement output.
 - **LSP:** Sets the volume for the device loudspeakers in decibel (dB).
 - **SR:** Sets the volume for the sound reinforcement output.
 - **Change EQ...:** Sets the equalizer for both the device's loudspeaker and the sound reinforcement output.
- **Line, Dante and OMNEO Inputs / Outputs:**
 - **In 1:** Sets the sensitivity of Line/Dante™/OMNEO input 1.
 - **Out 1:** Sets the sensitivity of Line output 1.
 - **Ambient:** Sets the ambient audio ON or Off for input 1:
 - ON:** Audio connected to **In 1** is only routed to the delegate headphones and the recorder output when no microphone is active.
 - Off:** (default setting): Audio connected to **In 1** is always routed to the delegate loudspeakers, delegate headphones, and the PA output.
 - **In 2** Sets the sensitivity of Line/Dante™/OMNEO input 2.
 - **Out 2:** Sets the sensitivity of Line output 2.
 - **In 2 / Out 2** mode selection menu: Defines the mode of Line/Dante™/OMNEO input 2 and Line/Dante™/OMNEO output 2. Click the arrow on the drop-down list to choose between:
 - LSP:** When selected, allows the audio from the delegate's loudspeaker to be amplified by an external system.
 - Recorder (Int. floor):** When selected, allows the audio to be recorded or sent to interpreters.
 - Mix - Minus:** When selected, prevents acoustic feedback when two systems are connected for example via telephone coupler.
 - Insertion:** When selected, allows an external system to process/equalize the audio. In this mode, headroom compensation is still active.
 - Unprocessed:** When selected, receives / sends the unprocessed audio (also referred to as dry signal) from **In 2 / Out 2**.
 - Mix - Minus unprocessed:** Only for **Dante In 2 / Out 2**. When selected, it increases the input delay to 15 m seconds and inserts the Dante audio after the local acoustical feedback suppression, to improve the audio when the system is used for hybrid meetings.
- **To configure the audio for hybrid meetings:**
 1. Set the audio of Dante Input 2 and Output 2 to Mix-Minus unprocessed and unmute them.
 2. In the Dante Controller, create a multicast flow for the Floor of DICENTIS-<hostname PC>MG.
For more information, refer to the section on how to create multicast streams of the chapter *Configuring Dante™ compatible devices, page 148*.
 3. Using the Dante Controller, route:
 - DICENTIS-<hostname PC> Dante Output Out 2 to DICENTIS-<hostname PC>-MG Floor
 - DICENTIS-<hostname PC>-MG Floor to DICENTIS-<hostname PC> Dante Input In2

Note: You need to download and install the Dante Controller software from Audinate.

- **Acoustic Feedback:**
 - **No Acoustic Feedback Suppression (AFS):** Off, sets the AFS function to “off”.
 - **Natural speech Acoustic Feedback Suppression:** Sets the AFS function to “on” and selects the natural algorithm for speech.
 - **Maximum Acoustic Feedback Suppression:** Sets the AFS function to “on” and selects the maximum algorithm for speech, which reduces the risk of acoustic feedback (howling) at higher system volume levels.
 - Note:** Audio artifacts might occur at higher volume levels.
 - **Loudspeaker is active when microphone is on:** Enables the loudspeaker of the device, when the microphone is on.
 - **Attenuate headphone when speaking by x dB:** x can be set using the textbox or the slider. The range of x is 0 dB up to 12 dB. Attenuates the headphone volume of the device, when the microphone is on.
- **Mute:** When selected, mutes the Line Input / Output or Dante Input / Output. There are separate mute buttons for **In 1 / Out 1** and **In 2 / Out 2**.
- **Test Tone:** To test the audio in the system. Select either **Off, 1 KHz,** or **Sweep**.
 - Note:** When a **Test Tone** option is selected the **Test Tone** checkbox appears in the **System** and **Line Input / Output** fields.
- **Headroom:** When **Unprocessed** is selected, the headroom can be set for the Line 2 and Dante 2 outputs. The range is from 3 dB up to 30 dB. **Headroom** is the buffer you have against transient peaks or loud sounds before the system goes into clipping.

5.4.6

Audio routing settings

The following options are available for the audio routing:

- **LSP:** Use this mode if you want audio output 2 of the Audio processor and powering switch to transmit a signal that can be connected to an external public address system. The Audio processor and powering switch sets:
 - volume signal level.
 - audio equalization.
 Audio input 2 signal of the Audio processor and powering switch is added to the floor signal.
- **Recorder (Int. floor):** This is the default audio I/O routing mode. Use this mode if you want audio output 2 of the Audio processor and powering switch to transmit a signal that can be connected to an external audio recorder or interpretation system. The Audio processor and powering switch has no effect on the volume level of the signal. Audio input 2 signal of the Audio processor and powering switch is added to the floor signal.
- **Mix - Minus:** Use the Mix-Minus mode to prevent acoustic feedback when two systems are connected, for example with a telephone coupler, via the audio input and audio output 2.
- **Insertion:** Use this mode to enable audio output 2 and audio input 2 of the Audio processor and powering switch to add signals from external audio devices. Headroom compensation is still active in this mode. If an unprocessed signal is required, leave the setting at the default position of -30 dB.
 - Example:** An external audio mixer is connected between audio output 2 and audio input 2 of the Audio processor and powering switch.

- **Unprocessed:** Use the Unprocessed mode to receive / send the unprocessed audio (also referred to as dry signal) to input 2 and output 2 of the Audio processor and powering switch.

See the following figure for a schematic overview of these settings:

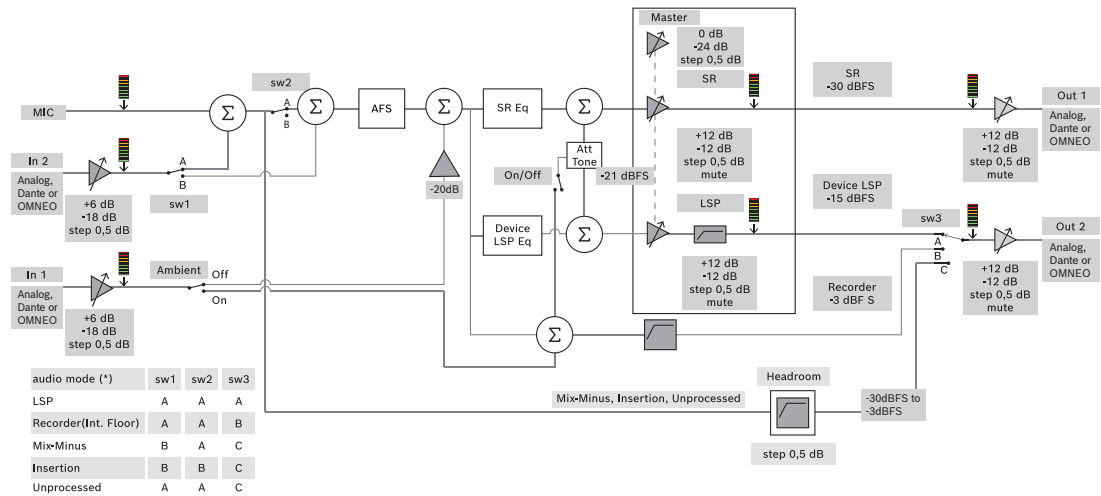

Figure 5.5: Audio Routing Settings

Notes:

- Inputs 1 and 2 can be the analog inputs of the Audio processor and powering switch, the Dante™, or the OMNEO inputs.
- Outputs 1 and 2 can be the analog outputs of the Audio processor and powering switch, the Dante™, or the OMNEO outputs.
- Only the analog outputs have -12 +12dB volume control.
- The analog, Dante™ and OMNEO inputs and outputs can be used simultaneously with a different configuration for each of them.
- If all Inputs/Outputs 2 are set to Insertion mode, then the order is: analog > Dante™ > OMNEO.

5.4.7

Camera Settings

This feature is available only upon registration. If you have a Premium or an Ultimate license, you can use the Media Gateway as a video management solution. Refer to *Configuring the Media Gateway*, page 111 for more information.

The camera settings page enables a technician to quickly and easily configure/update the camera settings.

- The Status column indicates whether a camera is connected (by means of a red cross or a blue check mark), enabling the technician to carry out any corrections. Cameras that are no longer used are marked by a red cross and can be easily deleted, using the minus (-) symbol.
- The camera name can be changed to a logical name, making it easy to find.
- The camera website can be quickly accessed by clicking a hyperlink.
- The camera type is automatically detected and displayed.

Prior to a meeting a technician can configure the camera:

1. Add the camera to the list of cameras.
2. Configure to which SDI input it is connected in the XML configuration file, see *Configuration Procedure*, page 120. The SDI makes it possible to dynamically switch HD-SDI video signals on the MMD or in the Meeting Application.

3. If required, configure the H.264 video stream of the camera. This can be an external H.264 encoder if necessary.
4. Configure the camera presets (Prepositions), allowing the technician to:
 - Call up presets
 - Pan, tilt, zoom the camera
 - Focus near, focus far
 - Store presets

During a meeting:

1. The system controls the camera via the stored presets.
2. The operator can control the camera via the PTZ-control (Pan, Tilt, Zoom) in the Meeting Application and modify presets and store them. The PTZ-control is called up by clicking the ... at the bottom right of the Meeting Application screen.

Camera Settings

- **Overview:** Defines the camera used as the overview camera.

The following video options are supported:

- Onvif Profile-S compatible cameras are automatically detected and displayed in the overview. As of version 2.7 also cameras are discovered when a username and password are configured in the camera. To be able to control the camera or display the video stream, when a username and password are configured, you need to enter the username and password in the general settings of the camera.
- Panasonic SDI/IP cameras which support HD Integrated Camera Interface Specifications version 1.06. The H.264 stream of the Panasonic cameras is not supported. An external H.264 encoder is required if the H.264 stream needs to be displayed on the multimedia devices. If the video stream only needs to be displayed on the Meeting Application, the H.264 stream of the Panasonic camera can be used (e.g. `rtsp://<ipaddress>/mediainput/h264/stream_2`).
- Sony SDI/IP cameras which support CGI Commands according to Sony standards (RCTG001, RTSP streaming function supported by Sony). The second H.264 stream of the Sony camera can be used to display on the multimedia devices and the Meeting Application. It is also possible to use an external encoder to encode the SDI stream for display on the multimedia devices and Meeting Application.

Note: The Sony camera needs to be placed in a separate VLAN to avoid problems with the multicast data.

Please configure the H.264 correctly so it will be displayed properly:

Image 2	
Image codec 2	H.264
Image size 2	704 x 576
Frame rate 2	25 fps
I-picture interval 2	5 S
H264 profile 2	Main
Bit rate compression mode 2	VBR
Image quality 2	6
Maximum bit rate limit 2	Yes
Max kbps	2500

Image 2	
Stream	rtsp://<ip address>/video2

- External video streams.

For specific video camera types see “System Overview” DICENTIS typical system setup.

Notice!

Ensure that the Bosch HD conference dome firmware 5.80 or higher. Configure the IP video stream according to the following settings:

- H.264.
- Set the main frequency of the HD conference dome from 50Hz to 60Hz to reduce the latency (Settings\Advanced mode\Camera\Installer Menu).
- 720p50 or 720p60.
- Target bit-rate 2Mbit/s.
- Maximum bit-rate 2.5Mbit/s.
- GOP length 15 (also known as I-Frame distance).
- No B-frames, I and P frames only.



- **Add:** Click the plus (+) symbol to add a new camera. Onvif Profile-S compatible cameras are automatically detected, but Panasonic and Sony cameras need to be added manually.
 - Enter the **IP address or host name** of the camera in the network. After saving the camera settings, you can click the blue hyperlink in the camera overview screen to access the camera website (allows for easy configuration of the camera).
 - Enter the **Camera user name** and **Camera user password**. The default username and password for Sony was “admin” “admin” and for Panasonic “admin” “12345” at the time this manual was written. As of software version 2.7, Onvif cameras with a username and password are discovered automatically. If a username and password has been configured for the camera, you have to enter this in the Meeting Application.
 - Enter the **H.264 video stream**. The H.264 image can be displayed on the MMD and in the Meeting Application. In case the image only has to be displayed in the Meeting Application, the camera’s H.264 stream can be used. If the stream also has to be displayed on the MMD, it is recommended to use the Epiphan (external H.264) encoder.
 - Select the **Control protocol**. <Panasonic> or <Sony>, for Panasonic or Sony cameras. Select <Unknown> if you want to add an external video stream.
- **Delete:** Click the minus (-) symbol to delete cameras that are no longer connected. Deleted cameras are also removed from the configuration file of the HD-SDI video switcher, which makes it easier to maintain.
- **Camera name:** this is the default name of a connected camera. In the **Camera name** column on the right side of the screen, you can change it to a logical name, e.g. right-side or front. This makes it easier to identify the camera when assigning it to a seat in the **Seats and devices** page. See *Seats and devices*, page 71.
- **Type:** This is the type of camera connected, e.g. PTZ (Pan Tilt Zoom).

Configuring additional video streams

The DICENTIS system can discover Onvif Profile-S compatible cameras, allowing the active speaker to be displayed on the multimedia device.

However, other video input solutions and even HD-cameras that convert their video through encoders can be configured, so that the DICENTIS system can detect them as if they are supported cameras. The provided video streams should comply with the standards used within the system (e.g. Real-Time Streaming Protocol, RTSP).

The H.264 (data type/codec) stream is packed in RTP stream according to:

<https://www.rfc-editor.org/info/rfc3984>

It can be configured as:

- direct RTP stream (unicast and multicast).
- RTP stream served by an RTSP server (unicast and multicast).

The settings of the H.264 stream are:

- Set the main frequency of the HD conference dome from 50Hz to 60Hz to reduce the latency (Settings\Advanced mode\Camera\Installer Menu).
- 720p50 or 720p60 if you have multimedia devices. 1080p50 or 1080p60 if you only have DCNM-IDESKVID devices.
- Target bit-rate 2Mbit/s.
- Maximum bit-rate 2.5Mbit/s.
- GOP length 15 (also known as I-Frame distance).
- No B-frames, I and P frames only.

5.4.8

Seats and devices

The main purpose of this screen is to assign seats to, and un-assign seats from, devices.

If the **Automatic seat assignment** checkbox under the **Rooms** tab is selected, a new device connected to the system is automatically assigned to a seat.

The **Automatic seat assignment** checkbox under the **Rooms** tab should not be selected if you want to manually assign and un-assign seats. Use the **Assign Device to Seat** button and **Unassign Devices from Seat** button to manually assign and un-assign devices. These buttons and their associated options are described in the following sections:

Seat Assignment pane

- **Configure mode (select on device):** Used for locating devices. When this checkbox is selected, a **Select device** button is displayed on all devices. Pressing this button or the microphone button:
 - switches on the microphone LED.
 - displays a crosshair in the **Select** column next to the seat and device name. When the device is selected, the crosshair is clear against a blue background. When the device is not selected, the crosshair becomes blue in a clear background. This feature can be particularly useful when you want to locate seat positions in a large conference hall.



Notice!

When **Configure mode** is active, the devices cannot be used for discussion purposes. Pressing the microphone button will function to locate the device.

If Synoptic Control is used and the **Configure mode (select on device)** checkbox is selected:

- The microphone LED on the device will be illuminated when moving the icon in the synoptic layout. This makes it easier to identify the device in the room during configuration.
- When the **Select device** button on the device is selected, the icon in the synoptic layout turns red.
- When the **Microphone** button on the device is selected, the icon on the synoptic layout turns red.
Note: The option is only available when there is no active meeting, because this would otherwise disturb the meeting.
 See also *First time login*, page 92.
- **Rename seats:** Enables you to assign logical names indicating the position of the seats in the room, e.g. Row 1, Seat 1.
 When **Configure mode** is active and this checkbox is selected, you can enter the name of the first seat that will be selected. The first device / seat on which the **Select device** or microphone button is touched will get the seat name that was entered. For each consecutive device, the number will be increased by one. If only text was entered in the seat name, the value will not increase.



Notice!

After renaming seats, deselect **Configure mode** to restore the discussion devices for regular use. When **Configure mode** is active, you cannot activate a meeting. Vice versa, when a meeting is in progress, you cannot use the **Configure mode**.

- **Select:** Used for locating assigned discussion devices.
 Click anywhere in a row to select it (the row is highlighted blue). Click the **Select** crosshair, and hold down the mouse button. A blue tick is displayed next to the seat and device name. The selected device is also indicated in the lower pane. To help you locate the seat position assigned to a multimedia device, the screen of the device will flash every time the mouse button is clicked.
- **Name:** This is the name of the seat. Double-click this field to select it. You can then type a new seat name.
- **Status:** Shows the status of multimedia devices assigned to seats:
 - Blue tick: Device is assigned to a seat.
 - Red cross: Device is unassigned from a seat.
- **Devices:** This is a list of the connected devices.
- **VIP:** Can be used to grant viewing rights for the voting results (interim-hold-closed results) to special persons and/or seats. The way the voting results are displayed is determined by the settings in **Vote settings**, Results. See *Voting round details*, page 57. Participants/seats with VIP rights can also view the waiting queue if the option **Show queue for participants** is disabled in the Discussion settings. See *Discussion profiles*, page 48.
- **Discuss:** For setting Discussion rights for seats.
- **Manage meeting:** For setting Manage meeting rights for seats.
- **Priority:** For setting Priority rights for seats.
- **VIS type** (Very Important Seat): This drop-down list is used to assign additional microphone authorizations to a seat, independent of the microphone mode and the number of open microphones:
 - **None:** No VIP settings selected.

- **Button operated:** Pressing the button once activates the microphone. This is the default setting for a chairperson.
- **Ptt Operated:** Push-to-talk. Press and hold to activate the microphone. This is the default setting used for an interruption microphone.
- **Voting:** This feature is available with Premium and Ultimate licenses. Seats can be assigned the **voting** function. The amount of seats with this functionality is displayed in the header of the column. When selected:
 - The number of free voting licenses decreases.
 - Voting sessions can be managed and controlled (DCNM-MMD2, Meeting Application, and API).
 - Votes can be cast on licensed DICENTIS devices, by touching the color-coded representative button on the displays of the devices.
 - The voting results are automatically displayed as color-coded bar graphs on the displays of the conference devices (Meeting Application, multimedia device, DCNM-DE, Synoptic application, and API).

Note: To manage and control voting within an active meeting, the user right **manage meeting** is required.
- **Identification:** This feature is available with Premium and Ultimate licenses. By checking the box, the seat will participate in the identification process as configured through the meeting preparation. This allows participant login **identification** credentials can be assigned to licensed seats. The amount of seats with this functionality is displayed in the header of the column.
- **Language selection:** This feature is available with Premium and Ultimate licenses. The language selection functionality can be assigned to seats. This enables participants to select an interpreted language on the respective seat. The amount of seats with this functionality is displayed in the header of the column. Only participants have access to the language selection functionality. If a device is not used by a participant, the functionality is not available in that device.
- **Camera:** This feature is available only upon registration, not for Premium and Ultimate licenses. This drop-down list is used to select a camera. The camera name can be changed in **Camera settings**. See *Camera Settings, page 68*.
- **Preposition:** This feature is available only upon registration, not for Premium and Ultimate licenses. Defines which preposition is used for the overview. This field is hidden, when the “camera selected for overview” does not support prepositions.
- **Unassign Devices from Seat:** Unassigns a selected device from a seat. Use the button like this: in the **Devices** column, click on the device you want to unassign (the row is highlighted blue). Click the **Unassign Devices from Seat** button. The **Status** column displays a red icon to show that the device is unassigned, and the details of the unassigned device appear in the **Unassign Devices from Seat** window. Hold down the **Ctrl** key and left click on the desired rows to make multiple selections.
- **Delete empty seats:** Removes empty seat rows. An empty seat row is created when a device is unassigned from a seat as explained above. Clicking the button will remove multiple seat rows at the same time.
- **Create Empty Seat:** Creates a new row for assigning a device to a seat.
- **Edit:** Allows changing the setting for multiple participants and seats. Hold down the **Ctrl** key and left click on the desired rows to make multiple selections.

Unassigned Devices pane

- **Select:** Used for locating unassigned multimedia devices.
Use the button like this: click anywhere in a row to select it (the row is highlighted blue). Click the **Select** checkbox, and hold down the mouse button. A blue crosshair is displayed next to the seat and device name. To help you locate the multimedia device, the screen of the device will flash every time the mouse button is clicked.
- **Name:** The name of the installed component, e.g. EINZ1315-MeetingApplication, MMD-5811430716101008-MultimediaDevice.
- **Type:** The type of device, e.g. MultimediaDevice.
- **Serial:** The serial number of the device, e.g. 5811430716101008.
- **Version:** The firmware version of the device, e.g. 2.70.17663.
- **Assign Device to Seat:** Assigns a selected device to a seat. Use this button when you want to replace an existing device, for example when the device is defective.
Use the button like this: click anywhere in a row to select it (the row is highlighted blue). In the **Seat Assignment** pane, click the seat that you want to assign the device to. In the **Unassigned Devices** pane, click the **Assign Device to Seat** button.
- **Create Seat from Device:** Creates a new seat row in the **Seat Assignment** pane with the selected device assigned to that seat.
Use this button when you want to quickly create new seat positions with devices automatically assigned. Click anywhere in a row to select it (the row is highlighted blue). Click the **Create Seat from Device** button. The device and the newly created seat appears in the **Seat Assignment** pane.

Notice!

Assign 2 microphones to the same seat

For a rostrum or chairperson seat, for example, you can create a seat with 2 microphones with the DCNM-FBD2. Assign both the 1-A and the 2-A devices to the same seat. This automatically configures the DCNM-FBD2 so that the audio level is equal to a seat with 1 microphone.

This only applies to a DCNM-FBD2 with 2 microphones inputs.

Do not use dual functionality in this setup.



Lower overview pane

This pane gives an overview of all installed components, such as the multimedia devices, (Audio) Power switches, Video Switcher, Meeting applications, and Cameras, and shows their version and status. It can be used to enable the power off functionality and volume control, and is useful for diagnostics purposes.

- **Select:** Used for locating multimedia devices.
- **Name:** The name of the installed component, e.g. EINZ1315-MeetingApplication, MMD-5811430716101008-MultimediaDevice.
- **Dual Use (24):** Allows the device to be shared by two participants (DCNM-FBD2, DCNM-D, DCNM-DE, and DCNM-DSL only).
- **Type:** The type of component.
- **Status:** The working status of the component.
- **Serial Number:** The serial number of the component.
- **Version:** The firmware version of the component.
- **Power Off:** Allows the device to power off the system (DCNM-MMD2, Meeting Application, Synoptic application, and API).

- **Volume Control:** Allows the device to control the master volume (DCNM-MMD2, Meeting Application, and API).

5.4.9 Participant Application

To configure the participant app, go to the **Participant app** tab under **Seats and devices**. Here, you can manage the registration process of the participant apps, get an overview of the apps registered in the system, and find a list of all registered apps.

Participant app registration management pane

This pane allows you to choose how the apps are registered in the system.

- **Username/password based registration:** Select this checkbox to enable the manual registration of the apps. Open a participant app you want to register and enter your user name and password. Click on **Register** to complete the process.
Note: Only users with **Configure system** rights can perform this operation.
- **Start Automatic Registration:** If you click this button, all the apps connected to the DICENTIS server network are automatically registered. You can stop the registration manually or set a timer to stop the registration automatically after the desired time.

Information pane

This pane gives you an overview of how many app licenses are active in the system, the number of connected apps, and the number of registered apps. It is possible to register any number of apps in the system, but only as many participant apps as the number of participant licenses can be active on the system.

Registered participant apps pane

Here, you can manage the registered apps. The registration is stored, which allows you to skip the registration process at the beginning of a meeting for apps that are already registered. In the list of registered apps, each row corresponds to an app and contains the following information:

- **Device ID:** Shows the ID of the tablet in which the app is running.
- **Registration method:** Shows how the app was registered in the system.
- **Last connection time:** Shows the last time the app was connected.
- **Assigned to seat:** Shows to which seat the app is assigned. If an app is permanently assigned to a seat, the field shows the respective seat name. If an app is temporarily assigned to a seat, the field is marked with the text "LINK".
 - Permanent assignment: This is performed on the **Seat Assignment** pane of the **Seats and Devices** tab. The participant apps are identified with the text "PAPP". You need to assign them to seats the same way you assign discussion devices.
Note: The seats should also be assigned with a discussion device, so that the participants are able to use the discussion features.
 - Temporary seat assignment: To use this assignment method, a participants needs to be assigned to a meeting and the meeting must be activated. The participant must log in to the participant app with the user account (configured under *Users*, page 62) and then log in to a seat using the identification method defined under *Meeting details*, page 53. The app is automatically assigned to this seat. When the meeting ends, the seat assignment is cancelled.
- **Connected:** Shows the connection status of the app.

In the Registered apps list, you can perform the following operations:

- **Manually add app by ID:** Insert an ID and press the + icon to add an app to the list manually.
- **Filter by:** Search by a device ID using a character sequence. Use an asterisk as a placeholder for any unknown character(s).
- **To remove an app from the list:** Select the desired app and press the - icon.



Notice!

For DICENTIS servers with a default configuration, everything is automatically configured correctly. Therefore, no actions are required.

If the SSL certificate of the DcnmSynopticControl site changes, the tablet registrations become invalid and need to be renewed. Refer to *Renewing the registration of the tablets*, page 153 for more information.

5.4.10

Language selection

Here you can configure:

- Which languages are available on the contribution devices
- **Language is displayed on contribution device as:**
 - **Original:** the original description of the language is displayed.
 - **Number and abbreviation:** the number assigned to the language in **Languages** along with its abbreviation are displayed.
 - **Number and original:** the number and the original description of the language are displayed.
 - **Abbreviation:** the abbreviation for the language is displayed.
 - **Skip unused (assigned) languages:** unused languages, displayed as (---) are skipped on the devices of participants. For interpreters unused languages cannot be skipped, as this would affect the order of the languages and the possibility to count the steps while setting up their inputs using the rotary on the interpreter device.
- **Dante I/O Licenses:** Shows the number of Dante™ I/O licenses divided in:
 - **Total Dante I/O licenses** Shows the total number of Dante™ I/O licenses.
 - **Dante inputs:** Shows the number of Dante™ licenses used for languages.
 - **Dante remote desk inputs:** Shows the number of Dante™ licenses used for languages coming from remote desks.
 - **Send to Dante:** Shows the number of licenses used to send languages to Dante™.
 - **Unprocessed send to Dante:** Shows the number of licenses used to send unprocessed languages to Dante™.
 - **Remaining Dante I/O Licenses:** Shows the number of remaining Dante™ I/O licenses.



Notice!

Some languages will not be available for participants and interpreters if the value of Remaining Dante I/O Licenses is below 0.

- **Unprocessed language streams:** Check this box to enable extra options to create a second stream for a language. This second stream can be used for external parties that require an unprocessed audio stream. It also allows the possibility to configure the **Unprocessed, Headroom, Send to Dante**, and **Floor filling** options per language.

Note: The DICENTIS system supports a maximum of 100 language streams. By enabling this option, the number of languages changes from 100 to 50 to allow for the second unprocessed stream per language.



Notice!

Unprocessed language streams can only be created for languages sourced by DICENTIS Interpreter desks.

- **Languages:** Shows the available translated languages received from the Conference system.
 - Press **'plus sign'** to add a language. The language is automatically entered according to the definition in **Sorting order**, see *Languages*, page 63. If a language is inserted within the language list, an empty language (---) will be added. If a language is inserted at the end of the list, the inserted language will be added after the language with the previously highest number used.
 - Press **'minus sign'** to remove a language.
 - Press **'arrow up'** or **'arrow down'** to change the order of the languages.
- **Order:** Shows the order in which the languages are displayed on the participant's devices.
- **Language:** Select the interpretation languages that are displayed on the participant's devices.
- **Source:** Select the source of the language that is available on the participant's device.

Options are:

- **Default:** When selected, the source language comes from the DICENTIS Interpreter desk. See *Interpreter desks*, page 79 on how to assign interpreter seats to, and un-assign interpreter seats from, devices.

Also select Default if the language comes from multiple sources (i.e. DICENTIS and/or OMNEO and/or Dante™). Use the Synoptic control, Conference protocol or .NET API to control which source provides the language.

This allows for interpreting of a language by a local interpreter (DCNM-IDESK) when the floor language is known or by an interpreter in a remote location (Dante™ or OMNEO) when the floor language is not known to the local interpreter.

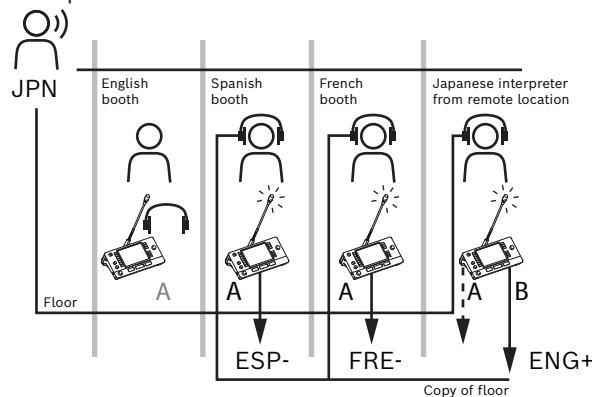

- **OMNEO:** When selected, the source language comes from a DCN NG system to which interpreter desks are connected via the OMNEO Media Interface (OMI), or from a Dante gateway which enhances the interface between a network that uses

OMNEO streams and a network that uses Dante™ streams. See *Floor and language routing, page 85* on how to configure the OMI channel(s) or connect a Dante gateway.

- **Dante:** When selected, the source language comes from a third party system using Dante™. The Dante™ source needs to be multicast. See *Configuring Dante™ compatible devices, page 148* for configuration options.

A Dante™ I/O (DCNM-LDANTE) license is required for each input.

Up to 100 languages can be received as Dante™ multicast streams. A license for 1 Dante™ stream is required for each language. The Dante Controller will show 100 Dante™ receivers representing the maximum of 100 languages that are available in DICENTIS. The number of the language in the Dante Controller relates to the number (order) in the list of languages in the DICENTIS Meeting application.

Note: if the language is not configured as Dante source or Send to Dante in DICENTIS, a green checkmark will not appear in the Dante Controller.



Notice!

Do not operate the Dante Controller on the same PC operating the DICENTIS services if that PC has 2 Ethernet cards. This will prevent issues with the Dante Controller.

- **Send to Dante:** When DICENTIS is selected as the source, the language can be sent to third party devices via Dante™ by ticking this checkbox. Requires a Dante™ I/O (DCNM-LDANTE) license for each output.

Up to 100 languages can be sent as Dante™ multicast streams. A license for 1 Dante™ stream is required for each language. The Dante Controller will show 100 transmitters representing the maximum of 100 languages that are available in DICENTIS. The number of the language in the Dante Controller relates to the number (order) in the list of languages in the DICENTIS Meeting application.



Notice!

The Dante™ streams of the DICENTIS system are made visible in the Dante Controller via the Dante Virtual Device, which is part of the services.

The Dante Virtual Device routes the audio, but does not control or configure it. That is the reason why the clock sync is displayed as red and other information about the streams is N/A or not displayed.

- **Displayed on device:** Shows how the language is displayed on the participant's device.
- **Unprocessed:** Select to make a language available as an unprocessed OMNEO multicast source so that it can be recorded or sent to a different system.
- **Send to Dante:** Select to make a language available as a Dante™ multicast source so that it can be recorded or sent to a different system. On the Dante™ side, languages 1 to 50 are the normal languages, and languages 51 to 100 are the unprocessed languages (e.g. the unprocessed Dante™ stream of Language 28 is Language 78).

Note: To select **Send to Dante** you first need to select **Unprocessed**.

- **Headroom:** It enables adjusting the headroom of the language so that you can adjust the level to the inputs of the receiving system.

- **Floor filing:** Select if you want to enable the language stream to be filled with the floor audio when no interpretation is active.
- **Source:** Shows the source, DICENTIS and/or OMNEO and/or Dante, of the remote interpreting. A language can have multiple sources: the DICENTIS Interpreter desks, OMNEO (Dante™ unicast stream using the OMN-DANTEGTW or DCN NG using the PRS-4OMI4), and/or Dante™ (multicast stream).

Enable language selection/settings

- To enable language selection on the devices, select the **Language selection** checkbox on the **Seats and devices** screen. See *Seats and devices*, page 71.



Notice!

It is possible to add or remove languages without disabling any microphone and interrupting the meeting.

5.4.11

Interpreter desks

There are two ways to configure the DCNM-IDESK / DCNM-IDESKVID:

- Interpretation setup in the Meeting application. This feature requires an Ultimate license.
- Interpretation setup on the DCNM-IDESK / DCNM-IDESKVID device itself. See *Configuring an IDESK (directly on the device)*, page 119.

For both methods, before configuring the interpreter desk, make sure the following settings have been made in the Meeting application:

- System languages have been defined in **Configure > Languages**. The language list can be extended with your own languages and the order of the languages can be defined, so frequently used languages are at the top. See *Languages*, page 63.
- Available languages on the participant devices have been defined in **Configure > Rooms > Language Selection**. See *Language selection*, page 76.

Note: If language selection must be available on the devices, select the **Language Selection** checkbox on the *Seats and devices*, page 71 screen.

Interpretation setup in the Meeting application

An Ultimate license is required for configuration via the Meeting application.

With the function **Interpreter desks**, you can create default settings for the interpreter desk and assign interpreter desks to, and un-assign interpreter desks from devices.

Use the **Assign device to desk** button and **Un-assign devices from desk** button to manually assign and un-assign devices. Use the **Create Desk from Device** button to create a desk from unassigned devices. These buttons and their associated options are described in the following sections:

- **Configure mode (select on device):** used for locating interpreter desks. When this checkbox is selected, a **Select device** button is displayed on all interpreter desks. Pressing this button:
 - switches on the microphone LED.
 - displays a blue background behind the crosshair symbol for the selected device. This feature can be useful when you want to locate desk positions in a number of interpreter booths.



Notice!

When **Configure mode** is active, the devices cannot be used for discussion purposes. Pressing the microphone button will function to locate the device.

General settings

These microphone modes are available **between booths** and **within the booth**:

- **Merge:** Multiple interpreter desks can have their microphones active for the same language. The system senses which microphone is being spoken into and uses that microphone for the interpretation. Merge can also be used to deliver 2 languages from one booth.
- **Interlock:** The signal of the active interpreter desk cannot be interrupted by another interpreter desk.
- **Override:** Other interpreter desks are allowed to override the signal of the active interpreter desk.

The extra microphone mode for **between booths** is:

- **Interlock on A and Override on B & C:** The signal on channel A cannot be interrupted by an interpreter desk from another booth, but the signals on channels B and C can be overridden.

The checkbox **Enable configuration on Interpreter desk** is selected by default. If you deselect the checkbox:

- The configuration mode via the B - B buttons is disabled. This prevents unauthorized people from being able to configure the device.
- The B - B buttons open a window that allows you to view system information and adjust the brightness of the display.



Notice!

When an interpreted language is not provided by an interpreter, then a DCNM-IDESK device will provide the floor audio to this language. This is called floor filling. For this to work properly, the number of devices must be equal or greater than the number of languages that are provided by DICENTIS.

Should a device providing the floor filling fail, then the floor filling will automatically be taken over by another desk. Discovering that a device is missing can take up to 15 seconds. If you have only 2 languages, then 1 device can provide this filling of the languages with the floor for both languages. This only happens when languages have DICENTIS source. If the source is OMNEO or Dante™, then the floor filling must be configured in these systems.

Speak slow settings

Allows the interpreter to signal that the current speaker is speaking at a pace too fast to interpret. The chairperson sees this signal in the DICENTIS Webserver, and can request the speaker to speak slower.

- **Release time of speak slow request:** Configure the seconds the speak slow request from the interpreter remains active after the speak slow button is released. The default is 1 second.
- **Minimum number of speak slow requests:** Configure how many speak slow requests need to be active for the speak slow signal turn On. The default is 3 requests.

- **Release time of speak slow signaling:** Configure the seconds the speak slow notification remains on after the amount of requests is under the threshold value. The default is 5 seconds.

Example: Since the active speaker is speaking too fast, the interpreters issue speak slow requests. The speak slow signal is activated when the minimum number of speak slow requests, 3, is reached. The chairperson warns the active speaker to speak slower. When the active speaker starts to speak slower, the interpreters release the speak slow button. When the release time of the speak slow requests, 1 second, has passed, the speak slow requests expire. The speak slow notification remains active for 5 seconds until the release time of the speak slow signaling expires as well.

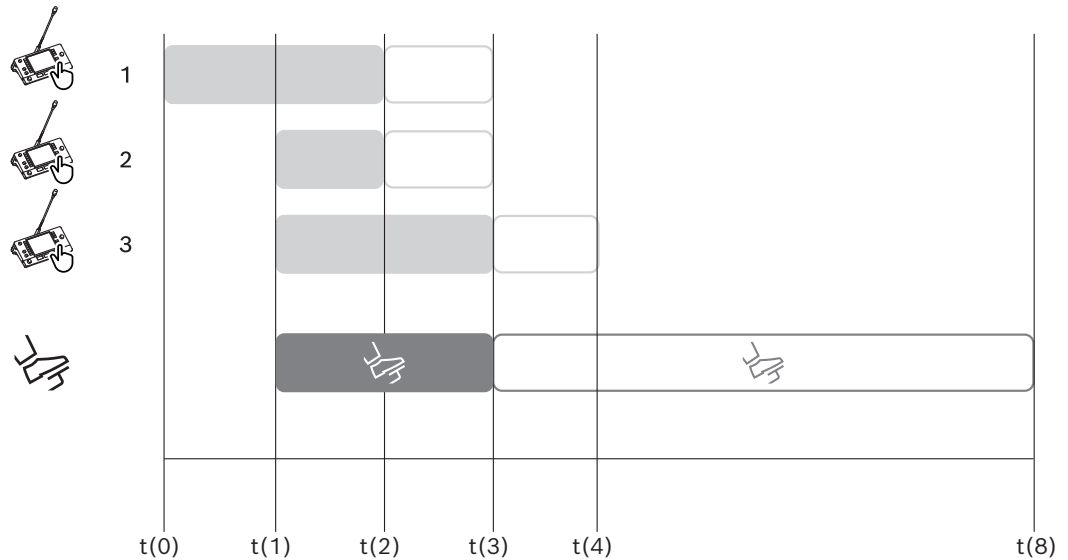

Figure 5.6: Speak slow example

Time	Action	Consequences
t(0)	The active speaker is talking at a pace that is too fast to interpret	
	Interpreter 1 issues a speak slow request	Only one speak slow request does not activate the speak slow signal
t(1)	Interpreters 2 and 3 issue speak slow requests	The minimum number of requests, 3, activates the speak slow signaling The chairperson asks the active speaker to speak slower
t(2)	The active speaker starts speaking slower	
	Interpreters 1 and 2 release the speak slow button	The release time of the requests, 1 second, starts counting Three requests are still active
t(3)	Interpreter 3 releases the speak slow button	The release time of the request from Interpreter 3 starts counting
	The release time for the requests of Interpreters 1 and 2 expires	With only one request active, the release time of the speak slow signaling, 5 seconds, starts counting The speak slow signal is still active

t(4)	The release time for the request of Interpreter 3 expires	The release time of the speak slow signal is still active. The speak slow signal is still displayed
t(8)	The release time of the speak slow signaling expires	There are no active requests, which inactivates the speak slow signal

Headphones

When you click on **Selectable headphones**, a dropdown list is displayed.

The interpreter can only select selectable headphones. If the headphones selected on an interpreter desk are removed from the list of selectable headphones, then the first available headphones will be selected.

Desk assignment pane

Shows information on the desk assignment for interpreter desks.

- **Select:** Used for locating assigned discussion devices.
Click anywhere in a row to select it (the row is highlighted blue). Click the **Select** cross-hair, and hold down the mouse button. A blue background behind the crosshair symbol is displayed for the selected device. The selected device is also indicated in the lower pane. To help you locate the desk position assigned to an interpreter desk, the screen of the device will flash every time the mouse button is clicked.
- **Booth:** The number of the booth the desk is assigned to.
- **Desk:** The number of the desk the desk is assigned to.
- **Status:** Shows the status of interpreter desks assigned to desks:
 - **Blue tick:** Device is assigned to a desk.
 - **Red cross:** No device is assigned to that desk, or the assigned device is not yet connected or discovered.
- **Devices:** The name of the desk.
- **A, B, C output:** Shows the name of the output language that the interpreter desk can interpret to.
- **E, F, G button:** Shows which function is assigned to each button.
- **Video sync:** Shows the value set for the audio delay for AV synchronization.
- **Headphones:** Shows which headphones are configured for the interpreter desk. Configuring which headphone is connected is required for hearing protection.

Buttons below Desk assignment pane

- **Un-assign devices from desk:** Un-assigns a selected device from a desk.
Use the button like this: in the **Devices** column, click on the device you want to un-assign (the row is highlighted blue). Click the **Un-assign Devices from desk** button. The **Status** column displays a red icon to show that the device is unassigned, and the details of the unassigned device appear in the **Unassigned Devices** window.
- **Delete empty desks:** Removes empty desk rows. An empty desk row is created when a device is unassigned from a desk as explained above. Clicking the button will remove multiple desk rows at the same time.

- **Create Desk:** Creates a new row for assigning a device to a desk. You can select the booth number, the desk number, and the language source (**Default**, **OMNEO**, or **Dante**). You can select Dante or OMNEO and allow the system to receive interpretations from remote interpreters.
- **Edit:** Opens the **Desk and Booth settings** pane for the selected device.
- **Auto Configure:** Automatically configures the selected device. This means the A output will be set to the language that corresponds to the booth number. The B and C output will be set to none and the seven buttons for the input languages will be configured as 1st button - 1st language, 2nd button - 2nd language, and so on.

Note: The **Edit** and **Auto Configure** options can be used for several (booth) desks at the same time. First, select all desks you want to edit or auto configure and then click the **Edit** or **Auto Configure** buttons. This helps with the easy configuration of the desks within a booth, since most of the time, booths are dedicated to interpret to one language and the same settings can be applied to all desks.

Desk and Booth settings

- **A output:** Allows you to select the language for the A output, usually the language the interpreter interprets to. You can only use a desk if an A output language is configured and is available in the meeting. Select **None** to disable the desk.
- **B / C output:** Allows you to select the language(s) for the B and C outputs from the list of available languages. If the A output language is selected for the B and C outputs, that language will be selected as default when the meeting starts.
- **E / F / G button:** Allows you to configure the functions for these buttons:
 - Switch between **Clock / Speech timer**. **Clock** shows the current time. **Speech timer** shows the elapsed time. This is the default function for the **E button**.
 - Switch between **Video / Presentation**. **Video** shows the camera view and **Presentation** shows the presentation stream, both on the external monitor. This is the default function for the **F button**.
 - Display a **Language overview** of the meeting languages with their respective interpretation status. This is the default function for the **G button**.
 - Signal to **Speak slow** to inform the chairperson that the current speaker is speaking at a pace that is too fast for interpreting.
 - Open the **Headphones / Headset** menu to select the headphone or headset you want to use for optimum audio quality and hearing protection.

FLR	No active interpreting. The floor audio is copied to the language
+	Direct interpreting
-	Relay interpreting
--	Double relay interpreting

Notice!



You can configure the E, F, and G buttons before every meeting. Once a meeting is deactivated, the configuration is set to default.

If you assign multiple functions to one of the buttons, this button is assigned with its default function.

If **Video / Presentation** is assigned on an interpreter desk without video functionality, an empty button is displayed.

- **Audio delay for AV sync:** Allows you to set extra options for the Audio delay for AV synchronization (only applicable when using the DCNM-IDESKVID).
- **Headphones:** You can configure which headphone has been connected, as well as define if the microphone of the headset is automatically selected or not.
- **Microphone:** Remove the tick from the checkbox if the stem microphone needs to be used when the device detects that a headset is connected.
Disabling the microphone of the headset will immediately result in switching from the headset microphone to the stem microphone without turning off the microphone functionality. It also works the other way around.
- **Source:** Select DICENTIS if a DICENTIS Interpreter desk is used. Select Dante™ or OMNEO when you want to use a remote system to provide the language.
- **Auto relay:** Tick the checkbox if this booth is an auto-relay booth. Normally the interpreter understands the floor language and interprets this to the target language. In situations where a speaker uses a language that most interpreters cannot interpret from, there is one interpreter who interprets into a language that most interpreters understand. The interpretation from the source language (the floor signal) into a language that the other interpreters understand is the auto-relay interpretation. The auto-relay interpretation automatically replaces the floor signal on all interpreter desks in the booth. All interpreters use the auto-relay interpretation to do their interpretations. When the booth has been configured as an auto-relay booth, all other booths will automatically switch from floor to auto-relay when the (auto-relay) booth is translating to output B.

Example:

The active speaker speaks Japanese. Auto-relay is enabled at the Japanese interpreter desk (in booth 1). The Japanese-to-English interpreter selects output B and sends an English auto-relay interpretation to all other interpreters. The LED next to the Floor/ Auto-relay buttons shows on all interpreter desks that the desks are receiving an auto-relay interpretation.

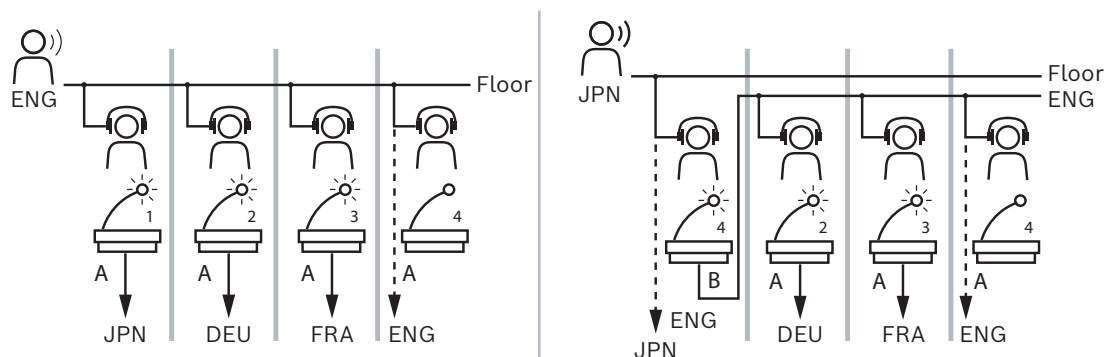

Figure 5.7: Normal and auto-relay interpretation

Unassigned Devices pane

- **Select:** Used for locating unassigned interpreter desks.
Use the button like this: click anywhere in a row to select it (the row is highlighted blue). Click the **Select** checkbox, and hold down the mouse button. The background behind the cross hair symbol of the selected device will become blue. To help you locate the interpreter desk, the screen of the device will flash every time the mouse button is clicked.
- **Name:** The name of the installed component, e.g. IDESK-0b2460.

- **Type:** The type of device, e.g. Interpreter desk.
- **Serial:** The serial number of the device, e.g. 5811430716101008.
- **Version:** The firmware version of the device, e.g. 2.70.17663.
- **Assign device to desk:** Assigns a selected device to a desk. Use this button when you want to replace an existing device, for example, when the device is defective. Use the button like this: click anywhere in a row to select it (the row is highlighted blue). In the **Desk Assignment** pane, click the desk that you want to assign the device to. In the **Unassigned Devices** pane, click the **Assign device to desk** button.
- **Create desk from device:** Creates a new desk row in the **Desk Assignment** pane with the selected device assigned to that desk. Use this button when you want to quickly create new desk positions with devices automatically assigned. Click anywhere in a row to select it (the row is highlighted blue). Click the **Create desk from device** button. The device and the newly created desk appears in the **Desk Assignment** pane.

Lower overview pane

This pane gives an overview of all installed components and shows their version and status.

- **Select:** Used for locating interpreter desks.
- **Name:** The name of the installed component, e.g. IDESK-0b2460.
- **Type:** The type of component.
- **Status:** The working status of the component.
- **Serial Number:** The serial number of the component.
- **Version:** The firmware version of the component.

Refer to

- *Configuring an IDESK (directly on the device), page 119*
- *Languages, page 63*
- *Language selection, page 76*
- *Seats and devices, page 71*

5.4.12

Floor and language routing

The DICENTIS system can be interfaced with other systems using OMNEO, for example:

- It can receive interpretations from DCN Next Generation using the OMNEO Media Interface (PRS-4OMI4);
- It can receive interpretations as Dante™ unicast streams using the Dante gateway (OMN-DANTEGTW);
- It can send interpretations to DCN Next Generation using the OMNEO Media Interface (PRS-4OMI4) to make use of the Integrus Wireless Language Distribution System;
- It can send interpretations as Dante™ unicast streams using the Dante gateway (OMN-DANTEGTW).



Notice!

Make sure the OMNEO Media Interface (PRS-4OMI4) is updated with BOTH the most recent DCN Next Generation download tool and the DICENTIS firmware upgrade to the same version that runs on the DICENTIS server. The OMNEO side of the Dante gateway (OMN-DANTEGTW) must be updated to the same version as the DICENTIS system.

In the **Floor and language routing** panel you can configure the floor and languages sent from and received at the DICENTIS system:

- The **top table** can be used to connect the OMNEO outputs to the DICENTIS inputs - this is used to receive interpretations coming from DCN Next Generation using the OMNEO interface.
 - The DICENTIS input number represents the language number of the meeting or the system.
 - Only one checkmark per row and column is allowed, since it is not possible to duplicate languages.

- The **bottom table** can be used to connect the DICENTIS outputs to the OMNEO inputs - this is used to send the floor and interpretations.
 - The DICENTIS output number represents the language number of the meeting or the system.
 - If you enable the **Unprocessed language streams** option in **Configure > Rooms > Language Selection**, the maximum number of language channels will become 50 (e.g. **Language 1, Language 1 Unprocessed**, etc.). This makes it possible to transmit both the normal language stream and the unprocessed language stream.
 - Only one checkmark per row is allowed
 - Multiple checkmarks per column are allowed, so that it is possible to route the interpretation to multiple receiving systems.

Receiving languages from DCN Next Generation

1. In the **Meeting application**:
 - Configure the OMNEO channel for delivering the Floor language to the DCN Next Generation system. By default, there is only one Floor language. If interpretation is provided by more than one DCN Next Generation system, you need to route the floor to the OMI devices connected to each DCN Next Generation system.
 - Configure which languages have DCN Next Generation as a source in chapter *Language selection, page 76*.
 - Configure which OMI outputs are connected to which DICENTIS OMNEO inputs on the Floor and language routing page.
2. Use the **DCN-IDESK** to:
 - Configure which language is on which DCN Next Generation channel. For more information on how to do this, refer to the 'DCN Next Generation installation manual'.
3. Use the **push/rotate button on the OMNEO Media Interface (PRS-4OMI4)** to:
 - Configure which OMNEO input is used to receive the Floor audio from DICENTIS. To do this:
 - select the OMNEO Input number.
 - configure the DCN Next Generation channel for Floor (00 is the Floor channel for DCN Next Generation).
 - Configure which OMNEO outputs are used to send the interpreted languages to DICENTIS. To do this:
 - select the OMNEO Output number.
 - configure the DCN Next Generation channel (01 - 31), which is forwarded to DICENTIS.



Notice!

To receive the floor from DCN Next Generation, connect an XLR cable between the DCN-CCU2 output 2 and the DCNM-APS2 input 2.

Sending languages to DCN Next Generation

1. In the **Meeting application**:
 - configure the OMNEO channel for delivering the Floor language and interpretations to the DCN Next Generation system.
2. **Use the push/rotate button on the OMNEO Media Interface (PRS-4OMI4) to:**
 - Configure which OMNEO input is used to receive the Floor audio from DICENTIS. To do this:
 - select the OMNEO Input number.
 - configure the DCN Next Generation channel for Floor (00 is the Floor channel for DCN Next Generation).
 - Configure which OMNEO inputs are used to receive the interpreted languages to DICENTIS. To do this:
 - select the OMNEO Input number.
 - configure the DCN Next Generation channel (01 - 31), which is received from DICENTIS.

Interfacing DICENTIS with DCN NG

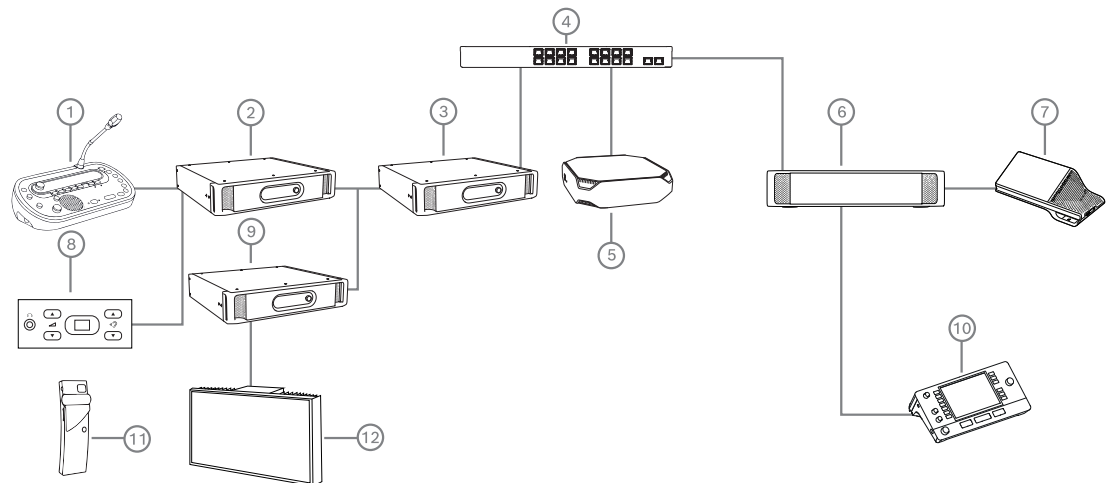

Figure 5.8: Interfacing DICENTIS with DCN NG

1. DCN-IDESK:
 - Interpreter desk for configuring which languages are on which output channels.
2. DCN-CCU2:
 - Central Control Unit for DCN Next Generation and DCN wireless systems.
3. PRS-4OMI4:
 - OMNEO Media interface with push/rotate button for assigning:
 - DCN NG channels to OMI outputs
 - DCN NG channels to OMI inputs
4. Network switch:
 - Connects the devices together on the network.

5. DICENTIS Server:
 - Assigns Language selection licenses to seats.
 - Configures the system channels.
6. DCNM-APS2 (Audio processor and powering switch):
 - Routes, controls, and processes the audio signals.
 - Supplies power to the DICENTIS devices.
7. Multimedia device, or Discussion device (DCNM-DE, DCNM-DSL):
 - Participants can select between Floor and the interpreted languages on the DICENTIS devices.
8. DCN-FCS:
 - Flush language selector for listening to a DCN NG or DICENTIS interpretation.
9. INT-TX:
 - Integrus transmitter for infrared language distribution.
10. DCNM-IDESEK or DCNM-IDESEKVID:
 - Interpreter desk for simultaneous interpretation.
11. LBB4540:
 - Integrus Pocket receiver
12. LBB451x/00:
 - Integrus radiator

**Notice!**

Participant devices can only be present in either the DCN Next Generation system or in the DICENTIS system.

Sending and receiving languages to/from Dante™ using the Dante gateway

The Dante gateway allows you to connect the DICENTIS system to unicast (glitch free) Dante™ streams. Using the Dante gateway, the languages come from a single source (the Dante gateway) instead of different sources (the DICENTIS interpreter desks).

To send streams from DICENTIS:

1. In the Meeting Application, configure which languages are provided locally (Default).
2. Use the **Floor and language routing** menu in the Meeting Application to route the DICENTIS transmitter streams to the Dante gateway receiver streams. See the *Floor and language routing* figure below.
3. Use the Dante Controller or Dante Domain Manager™ on the Dante™ side of the Dante gateway to route the Dante gateway transmitter streams to 3rd party receivers.

To receive streams on DICENTIS:

1. In the Meeting Application, configure which languages are provided from the Dante gateway (OMNEO).
2. Use the Dante Controller or Dante Domain Manager™ on the Dante™ side of the Dante gateway to route 3rd party transmitters to the Dante gateway receiver inputs.
3. Use the **Floor and language routing** menu in the Meeting Application to route the Dante gateway transmitter streams to the DICENTIS receiver inputs. See the *Floor and language routing* figure below.

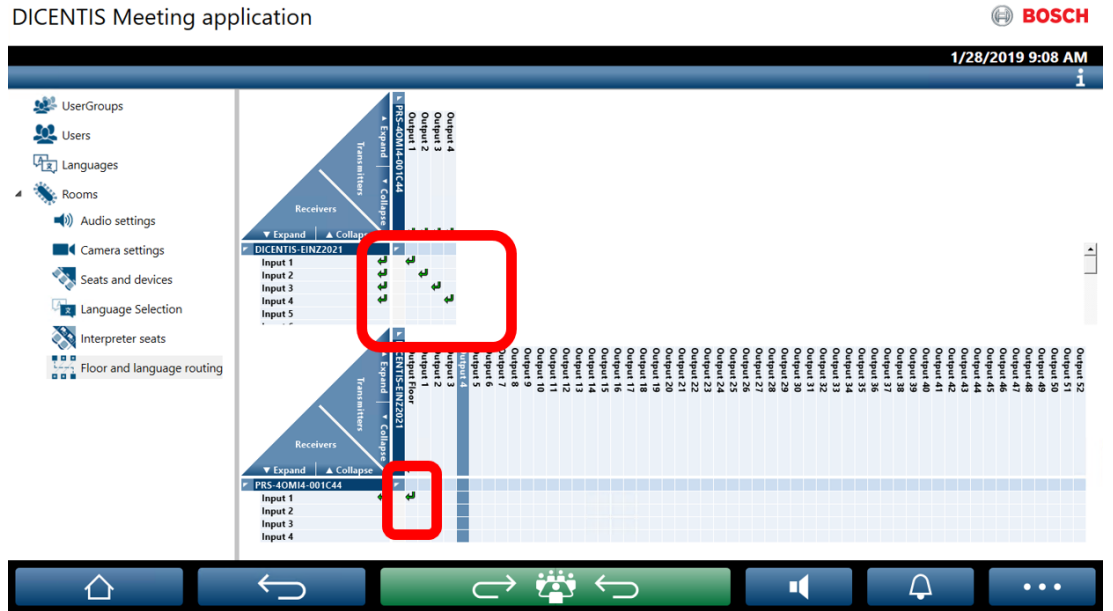

Figure 5.9: Floor and language routing

Connecting two DICENTIS systems

It is possible to connect two or more rooms together using the Dante gateway: one room for the participants in the discussion and the interpretation; and the other rooms for the audience and additional interpretations:

- The configuration for each room is done separately
- The Dante™ network is used for routing and recording the audio
- The **Dante** network is configured using the Dante Controller or Dante Domain manager

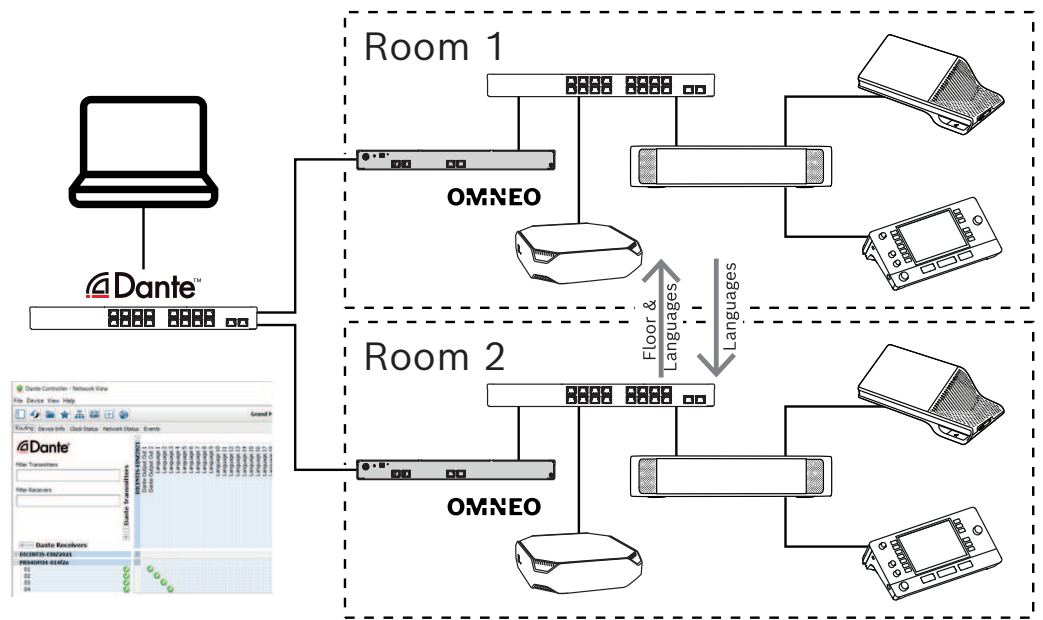

Figure 5.10: Dante gateway configuration

Note: Using mix-minus you can have participants speaking in two rooms. Mix-minus does not work in more than two rooms.



Notice!

If the discussion is only held in one room, use “**Recorder (Int. floor)**” to deliver the floor to the other room.

6 DICENTIS Webserver

The DICENTIS Webserver is automatically installed on the DICENTIS Server with the server software. It uses the Conference protocol for communication.

A chairperson or clerk can have more control over a meeting by granting or stopping speech via a visual layout of the speakers’ room, thus making the discussion more productive. These layouts also show the individual voting results, as well as quorum and majority.

The Webserver offers easy access to the voting files and to the meeting notes so that you can view or print them.

For **hall display purposes**, it offers:

- Display of the speech timer;
- Display of the voting timer;
- Meeting and agenda information;
- Voting information and total voting results displayed Pie-chart or Bar graph;
- Quorum and majority information.

The **operator** can use it to:

- Chat with the participants;
- Manage the meeting agenda;
- Control the presentation;
- Control voting rounds;
- Manage the speech timer;
- See the status of the interpreter desks and booths and control them;
- Use the power on/off functionality;
- Master volume control.

Since different users require different views, it is possible to create multiple Synoptic views. The last opened view will be remembered and opened upon the next login.

Control and configuration of the various functionalities depend on the user/person rights. Please refer to the table below for an overview:

	Rights	Microp hone status	Voting	Attenda nce	Interpr eting	Meetin g notes & voting files	Volume control	Power on/off	Configu re webser ver
User	None	view	view	view	-	-	-	-	-
	Activat e meetin g	view and control	view and control	view	view and control	view	control	control	-

	Prepare meeting and agenda	view	view and control	view	-	view and delete	-	-	-
	Assign access rights	view	view	view	-	-	-	-	-
	Configure system	view and control	view	view	view and control	view	control	control	configure
Person	Not a participant	-	-	-	-	-	-	-	-
	Participant	view	view	view	-	-	-	-	-
	Participant with manage meeting rights	view and control	view	view	view and control	view	view	view	-

**Notice!**

Internet Explorer is no longer supported as of version 3.2.

6.1**First time login**

The DICENTIS Webserver uses an https connection and a certificate to secure the connection. The first time you log in on the server device, the new certificate is automatically installed.

On a client device, the certificate has to be manually installed:

1. From your client device, open the address <http://<server>/DICENTISCertificates>.
2. Select the language of your instructions on the drop-down menu at the top right corner of the page.
3. Follow the instructions to download the certificate and configure the browser.

Note: If your browser is not automatically recognized, select the correct browser using the drop-down menu at the top of the page.

6.2 Configuration procedure

Precondition

- To use this page, the logged in user must belong to a User Group that has the right Configure System (for example, Admin User).

To configure the synoptic views:

1. Log in with the user "Admin" in the synoptic application.
 - Click the **Select background** button, and select a suitable background for the room.
 - Click the **Start configuration** button.
 - Drag and drop the synoptic icons to the place where they are physically sitting in the room. You can also remove unwanted seats from the layout by dragging and dropping them back to the seats list. Use **Show grid** and **Snap to grid** for easier placement in a (large) room.
 - Drag and drop the Booth, Majority, Quorum, and/or Voting icons to the desired place in the synoptic layout.

Note: If **Start illuminate device** has been selected in the synoptic application, the microphone LED illuminates when moving the device icon in the synoptic layout, so it can be easily identified in the room. If the **Select device** or **Microphone** button on the device is selected, the icon in the synoptic layout turns red.

 - Adjust the size of the icons using the blue plus and minus sign.
 - Once you are satisfied with the layout, click **Stop configuration**.
2. The synoptic layout can automatically switch to displaying voting results when a voting round is open. This can be configured via the **Manual / Auto switch** button. The Web client seat requires a voting license to display the voting results.

Multiple synoptic layouts

It is now possible to have multiple layouts that can be selected during a meeting.

To manage the layouts:

- ▶ Click the **Layouts** button on the right side menu to open the **Edit Layouts** window. Here you can add, configure, delete, rename or change the preferred order of the different layouts.
- ⇒ If more than one layout is available, the user can switch between the different layouts using the drop-down list at the bottom of the screen.

Display voting as a pie or bar chart

1. The chart makes use of the **Display total results** setting for the **External system**. If **Display total results** is set to **Never**, the chart cannot be drawn.
Refer to *Results -> Selection* in *Voting round details*, page 57 for more information.
2. It is required to configure the 100% setting of the voting round to define the size of the circle. If there is no 100% setting configured, the chart cannot be drawn.
Refer to *Majority -> Majority calculation* in *Voting round details*, page 57 for more information.

6.3 Control microphones



Notice!

If the IP-address of the DICENTIS server has changed, the synoptic control button may no longer be found in the Meeting Application. To solve this, go manually to the correct address once: <http://<IP address DICENTIS Server or hostname>/synopticcontrol>.

Manage speakers' microphones

1. Make sure there has been a first time login and use of participant pictures.
2. Log in to the **Synoptic control**:
 - With a username and password of a User that has “Activate meeting” rights, or,
When a meeting is activated, with a username and password of a participant that has “Manage meeting” rights.
3. Left-click the synoptic icons to:
 - Grant the floor to a participant.
 - Stop the active speaker.
4. Right-click the synoptic icons to have extended control over the participants' microphones. Different sets of actions are available in the different discussion modes.

Discussion mode - Open:

- If a participant's **microphone is off**, you can:
 - Grant the floor to the participant.
 - Add the participant to the speaker queue.
- If a participant is **in the speaker queue**, you can:
 - Shift the participant's position.
 - Remove the participant from the speaker queue.
- If a participant is **speaking**, you can:
 - Stop the active speaker.

Discussion mode - Response:

- If a participant's **microphone is off**, you can:
 - Grant the floor to the participant.
 - Add the participant to the speaker queue.
 - Add the participant to the responder queue when another participant is speaking.
- If a participant is **in the speaker queue**, you can:
 - Shift the participant's position.
 - Remove the participant from the speaker queue.
 - Add the participant to the response queue when another participant is speaking.
- If a participant is **in the response queue**, you can:
 - Shift the participant's position.
 - Remove the participant from the response queue.
 - Add the participant to the speaker queue.
- If a participant is **responding**, you can:
 - Stop the active responder.
 - Mute/unmute the active responder.
- If a participant is **speaking**, you can:
 - Stop the active speaker.
 - Mute/unmute the active speaker.

Discussion mode - First in First out:

- If a participant's **microphone is off**, you can:
 - Grant the floor to the participant.
- If a participant is **speaking**, you can:
 - Stop the active speaker.

Discussion mode - Voice:

- There are no actions available in this discussion mode

**Notice!**

It is not possible to mute/unmute a meeting participant joining from remote.

**Notice!**

Due to privacy reasons, when the floor is granted to a participant joining remotely, that participant's microphone remains muted. To speak, the remote participant needs to unmute the microphone.

The Synoptic icon is displayed in different colors to show the participant state:

- Speaking / Responding - red
- Not speaking / Microphone off - gray
- In the speaker queue - green
- First in the speaker queue - green blinking
- In the response queue - yellow
- First in the response queue - yellow blinking

Change synoptic layout from Microphone control to Voting results

The synoptic layout can be manually switched between showing microphone status and showing individual voting results by using the two icons in the bottom bar. If the option has been configured to switch automatically to display individual voting results, the operator can always switch manually back and forth.

Adjust individual microphone sensitivity

You can adjust the microphone sensitivity according to the voice of the active speaker. If you right-click the synoptic icon of the active speaker and then select **Set microphone sensitivity**, the sensitivity slider bar is displayed.

The microphone sensitivity is set to 0 dB by default, and it can be adjusted within a range of -6 dB and 6 dB. You can increase and decrease the sensitivity value by 0.5 dB if you drag the slider up and down or press the + and - buttons.

6.4 Manage speech time

When enabled, you can include the speech timer in the Synoptic layout through the element list. The timer is displayed per speaking turn, following the order defined in the speaker list. It is not displayed when the participants with VIP or VIS rights have the floor.

The speech timer can present one of the following status:

Color/Status	Description
Green	Time is running.
Red	Only 60 seconds left of the time initially set.
Overtime	The time initially set is exceeded. The timer remains in red as it continues to count and display the time in negative values.

If you select the checkbox **Adjust speech time** in the discussion settings of the Meeting Application, a participant with Manage meeting rights or user with Activate meeting rights can adjust the speech timer in the Synoptic view. It is possible to set the timer to a maximum of 99 minutes, using the + / - buttons of the speech timer window, and reset the timer after it starts running to the time initially set.

6.5 Control voting rounds

In the Synoptic view, the clerk is able to manage prepared voting rounds and ad hoc voting rounds.

If you click the Voting icon on the taskbar of the Synoptic view, a floating window appears. It is possible to adjust the location and size of this window. The window can present two options:

- Manage a prepared voting round
- Manage an ad hoc voting round



Notice!

The options available in the voting round control window are determined based on the type of licenses you have. For example, if you have a system with Premium licenses, the window only offers the possibility of managing ad hoc voting rounds. If you have a system with Ultimate licenses, the window offers the possibility of managing both ad hoc and prepared voting rounds.

After you open the voting round control window, perform the following steps:

1. Either:
 - Select a voting round from the list of prepared voting rounds, or
 - Insert the details of an ad hoc voting round, by filling in the **Number**, **Subject**, and **Description** fields. Only the **Number** field is mandatory.
2. Click on **Ready to vote**.
3. The window presents the details of the voting round you chose in step 1. You can either:
 - Click on the **Recall** button to go back to step 1, or
 - Click on the **Open** button to open the voting round you chose.
4. The window presents a progress tracker, which shows the status of the voting round. You can:
 - Click on the **Pause/Resume** button to pause and resume the voting round.
 - Click on the **Abort** button to abort the voting round and go back to step 1, or
 - Click on the **Close** button to close the voting round.

5. If you click the **Close** button in the previous step, the window displays the progress tracker completed. You can either:
 - Click on the **Accept** button to accept the results of the voting round, or
 - Click on the **Reject** button to reject the results of the voting round.







In the vote settings of the Meeting Application, if you enable the voting timer for a voting round, you can include it in the synoptic view through the element list while you hold the voting round. This is only possible if you have a Premium or an Ultimate license.

6.6 Control presentation

You can control the presentation source in the Synoptic view. This feature is available for:

- Users with Activate meeting rights.
- Participants with Manage meeting rights.

Use the buttons/icons on the taskbar of the Synoptic view to control and check the status of the presentation source:

Button/Icon	Description
	This status icon is displayed in the taskbar when no presentation is being shared. Click the icon for more options.
	Access this button by clicking the status icon. Click the button to start sharing the local presentation.
	This status icon is displayed in the taskbar when the local presentation is being shared. Click the icon for more options.
	Access this button by clicking the status icon. Click the button to stop sharing the local presentation.
	This status icon is displayed in the taskbar when a remote participant is sharing the screen. Click the icon for more options.
	Access this button by clicking the status icon. Click the button to stop the remote participant from sharing the screen.



Notice!

In a system with DCNM-CRN and DCNM-RENTAL licenses, it is only possible to control local presentations. In a system with DCNM-DEMO, Premium, and Ultimate licenses, you can control both local and remote presentations.

6.7 Control agenda

If you click the Agenda control icon on the taskbar of the Synoptic view, a floating window appears. It is possible to adjust the location and size of this window.

The Agenda control window presents the list of agenda items prepared for the active meeting. This functionality is only available if you activate a prepared meeting. In ad hoc meetings, you are not able to use this functionality.



You can use the **Open/Close** buttons to open and close the agenda items. If you open an agenda item, the respective row is highlighted. As you scroll through the agenda items, this row remains highlighted and visible at the top of the list.



6.8 Control meetings

It is possible to manage meetings through the Synoptic control. The actions performed via the Synoptic control are reflected in the Meeting Application and the other way around. After you log in to the Synoptic control, click the **Meetings** tab to go to the Meetings view. The Meetings view displays a list of the prepared meetings. You can search a meeting by its name or use the **Start date** and **End date** fields to filter the results displayed in the list. In the Meeting application, if you go to **Prepare > Meetings**, you can enable or disable the checkbox **Automatically open meeting on activate and deactivate on close meeting** for each meeting. This setting determines how you can control the meetings in the Synoptic control.

To control a meeting through the Synoptic control:

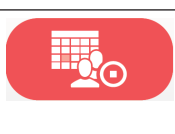

1. Find the row corresponding to the meeting you want to control in the Meetings view.
2. If you want to control a meeting for which the checkbox is enabled, **Open** is available in the Action column: Click **Open**. The **Close** button replaces the **Open** button. If you want to control a meeting for which the checkbox is disabled, **Activate** is available in the Action column: Click **Activate**. The **Close** and **Deactivate** buttons replace the **Activate** button.
3. Use the following buttons/icons to control and check the meeting status:

Button/Icon	Description	
	This status icon is displayed in the taskbar when a meeting is activated. Click the icon for more options once you are in the Synoptic view.	Buttons/icons available to control all meetings.
	This status icon is displayed in the taskbar when a meeting is open. Click the icon for more options once you are in the Synoptic view.	

	<p>This icon is always available in the taskbar. Click the icon to switch between the Meetings view and the Synoptic view.</p>	
	<p>Access this button by clicking the status icon once you are in the synoptic view. Click the button to deactivate the meeting.</p>	
	<p>Access this button by clicking the status icon once you are in the synoptic view. Click the button to close an open meeting.</p>	<p>Buttons/icons available to control meetings for which the checkbox is enabled.</p>
	<p>Access this button by clicking the status icon once you are in the synoptic view. Click the button to open a meeting that is closed.</p>	

6.9 Switch between synoptic views

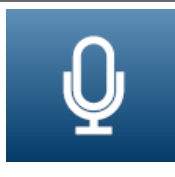
During a meeting, you can switch between synoptic views. On the left side of the taskbar, you find three buttons. Use these buttons to switch between synoptic views and check which view is active. When you activate a synoptic view, the respective icon is displayed with a white bar on top.

Button	Synoptic view
	<p>Discussion view: Shows the discussion status of the seats and allows you to manage the discussion.</p>
	<p>Microphone sensitivity view: Shows the microphone sensitivity of the microphones and allows you to adjust it.</p>
	<p>Voting view: Shows the voting information of the participants.</p>

6.10 Chat with participants

The operator / clerk can chat with the participants in order to provide support in case there are issues.

Click the message icon on the taskbar of the Synoptic view to access the chat functionality.

You can:

- Search for a participant and start a conversation.

- Open unread messages and reply to the participants.
If you have unread messages, a notification appears on top of the message icon on the taskbar of the Synoptic view.

Note: Only participants who join remotely can send and receive messages in the chat.

6.11 Setting up automatic login and layout selection for hall displays

You can use the DICENTIS Webserver on a hall display or monitor. You can configure the web browser on the hall display to:

- Login automatically
- Select the layout for that monitor
- Run the browser in full screen
- Hide the bottom bar of the synoptic layout.

You can also use these functions to, for example, automatic select the layout for the chairperson.

To create a user for the hall display

1. Open the **Meeting application** with administrator rights.
 2. Click **Configure**.
 3. In **User Groups**, click the **+** sign to create new a user group. Do not checkmark any **Access rights**.
 4. In **Users**, click the **+** sign to create a new user.
 5. Give the user a **User name**.
 6. To assign the new user to the user group you just created, select the new **User group** from the drop-down list.
 7. Click **Change password** to create a password for the new user.
- You can close the Meeting application.

To configure the web browser on the hall display

1. Open a web browser in the PC connected to the hall display.
2. Follow the instructions in *First time login, page 92* to install the necessary certificate.
3. Download the file `https://<hostname DICENTIS server>:31416/downloadAutoLogin.html`.
4. Create the folder `c:\halldisplay\`.
5. Copy the downloaded file to the new folder.

To create a shortcut that opens automatically when powering up the PC

Note: The following instructions are specific to Google Chrome. Change as needed if you use other browser.

1. Right-click your desktop.
2. Click **New**.
3. Click **Shortcut**.
 - The **Create Shortcut** window appears.

4. In **Type the location of the item**, write
"C:\Program Files (x86)\Google\Chrome\Application\Chrome.exe"
-start-fullscreen "file:///C:\halldisplay\autoLogin.html?Server=https://<hostname
DICENTIS server>:31416/&navbar=off&layout=<layout name>"
 - **"C:\Program Files (x86)\Google\Chrome\Application\Chrome.exe"** to select Chrome as the browser.
 - **-start-fullscreen** to start Google Chrome in full screen mode.
 - **"file:///C:\halldisplay\autoLogin.html"** for the browser to automatically log in without having to enter the username and password. A notification page will be displayed if the hall display computer cannot connect with the DICENTIS Server.
 - **Server=https://<hostname DICENTIS server>:31416/** to direct the shortcut to the DICENTIS Webserver. Replace <hostname DICENTIS server> by the hostname of the DICENTIS Server.
 - **navbar=off** to hide the bottom navigation bar.
 - **layout=<layout name>** to select the requested layout automatically and skip the main page. Replace <layout name> by the name of the layout.
5. Click **Next**.
6. In **Type a name for this shortcut** write a logical name, such as "hall display".
7. Click **Finish**.
8. Move the shortcut to the startup folder: C:\Users\All Users\Microsoft\Windows\Start Menu\Programs\Startup.
9. Double-click the shortcut.
 - The browser opens full screen in the start page of the DICENTIS Webserver.
10. Log in the **User** you created with limited rights.
 - A security token is created for the automatic login. As such, make sure that your last login is always the user with limited rights.
11. Log out the DICENTIS Webserver.

The configuration is complete. Next time you power up the PC, it automatically will:

- Open the browser in the selected mode.
- Log in the DICENTIS Webserver.
- Show the synoptic layout that you chose.
- Hide the bottom navigation bar.

Tips if you are using a Windows PC

- You can configure Windows to log in automatically. Search how for your specific Windows version online.
- You can configure Windows to hide the taskbar:
 1. Right-click the **taskbar**.
 2. Select **Taskbar settings**.
 3. Slide **On** in **Automatically hide the taskbar in desktop mode**.

6.12 Post-meeting tools

Depending on the installed licenses and system settings, the DICENTIS system can automatically create XML meeting notes files and voting results files that can be used for post meeting analysis (i.e. for making the minutes of a meeting). The meeting notes files and voting results files have their own XSLT style sheets that enable the XML content to be

easily viewed in a browser. The “look up table” in these style sheets can be modified so that information can be displayed, for example, in the local language. See the following sections for more information.

By default, the XML meeting notes files and voting result files (both with authenticity check) are saved on the Server PC. If required, the location for saving these files can be changed. For the meeting notes, see explanation in **Meeting notes location** in section *Rooms*, page 63.

6.12.1 Access through the Webserver

You can access the voting results and meeting files from the main page in the DICENTIS Webserver.

Select **Voting files and meeting files** to go to the Voting files and meeting files page, which is visible for:

- a participant with “Manage meeting” rights, to see the notes.
- a user with “Activate meeting” rights, to see the notes.
- a user with “Prepare meeting” rights, to see and delete the notes.

Once in the notes page, choose what you want to see in the **File type** drop-down menu:

- **All files:** displays voting and meeting notes.
- **Meeting notes:** displays only meeting notes.
- **Voting notes:** displays only voting notes.

Fill the **Start date** and **End date** periods, and use the search bar to search by a keyword.

The results will appear on the left side of the screen:

- **File name:** the name of the file.
- **Date created:** the date when the notes were created.
- **Delete:** click the icon to delete the file.

A preview of the file will appear on the right side of the screen. By hovering over the preview, you can choose the **Print** icon, to print the selected notes, or the **Expand** icon, which will open the notes in a new page. The third icon warns of the authenticity of the meeting and voting XML data, which is verified when the file is previewed. Refer to *Authenticity check*, page 104 for more information.

The message **Could not preview the file** will appear when:

- the meeting related to those notes is still active, or
- the file was not properly closed (which happens, for example, when the computer is restarted with the meeting active).

On the **meeting notes**, you will find:

- A summary of the meeting;
- Lists of the present and absent participants;
- An overview of the agenda items;
- Voting rounds information;
- Quorum and majority information.

On the **voting notes**, you will find:

- The number, subject and description of the voting round;
- The voting round configuration;
- The summary of the voting round, including who was present;
- Individual and group results;
- Quorum and majority stored at the closing of the voting round.

6.12.2 Modifying the XSLT style sheets

XSLT style sheets for the meeting notes files and voting notes files are included in the location where the voting results are saved, which enables the XML content to be easily viewed in a browser.

You can modify the “look up table” in these XSLT style sheets so that information can be displayed, for example, in the local language. To do this:

1. Browse to the same folder you selected to save the meeting notes in on the DICENTIS server. See explanation in **Meeting notes location** in section *Rooms*, page 63.
2. Make a backup of the XSLT style sheet.
3. Use a source code editor (for example Notepad++) to open the XSLT style sheet.
4. In the look up table, modify the select values, as required. Do not change the name values. See the following example.

Default settings for select:

```
<xsl:variable name="variableMeeting" select="'Meeting'" />
<xsl:variable name="variableMeetingName" select="'Name: '" />
<xsl:variable name="variableDescription" select="'Description: '" />
```

Select value modified for the local language:

```
<xsl:variable name="variableMeeting" select="'Vergadering'" />
<xsl:variable name="variableMeetingName" select="'Naam: '" />
<xsl:variable name="variableDescription" select="'Beschrijving: '" />
```

Change and modify the displayed logo:

```
<xsl:variable name="variableLogoPath" select="'path of the logo'"/>
<xsl:variable name="variableLogoHeight" select="'100'"/>
<xsl:variable name="variableLogoWidth" select="'100'"/>
```

6.12.3 Adding custom setting to style sheet after a software update

When the DICENTIS software is updated, the existing XSLT style sheet is not overwritten, as this would delete any custom settings. Instead the installer copies a new version of the style sheet, containing all latest updates, to the `:\ProgramData\Bosch\DICENTIS\` default directory, or to the location you entered if you changed the location where results are stored.

Use the following procedures to update new style sheets (and add any custom settings from the previous style sheet):

MeetingResult.xslt style sheet:

1. Rename **MeetingResult.xslt** to any suitable name, for example **MeetingResult_old1.xslt**.

2. Open the automatically created **MeetingResult_new.xslt**, and apply the same customization as for **MeetingResult_old1.xslt**.
3. Add any new customization to **MeetingResult_new.xslt**, as required.
4. Rename **MeetingResult_new.xslt** to **VotingResult.xslt**.

VotingResult.xslt style sheet:

1. Rename **VotingResult.xslt** to any suitable name, for example **VotingResult_old1.xslt**.
2. Open the automatically created **VotingResult_new.xslt**, and apply the same customization as for **VotingResult_old1.xslt**.
3. Add any new customization to **VotingResult_new.xslt**, as required.
4. Rename **VotingResult_new.xslt** to **VotingResult.xslt**.

Note: The installer will always overwrite **MeetingResult_new.xslt** and **VotingResult_new.xslt** during a software update, therefore you should not use these filenames to store any custom settings.

6.12.4

Authenticity check

The meeting and voting notes have an authenticity mechanism to validate them. The 3.60 software version introduces certificate technology, which is more secure against tampering.

Check if the file was tampered with by hovering over the preview to see the authenticity icons:

- Shield icon with tick mark: **Authenticity check passed** based on certificate technology.
- Shield icon: **Authenticity check passed** based on 3.50 or previous releases authenticity check.
- Warning triangle icon: **Authenticity check failed**. This happens when the file was tampered with, or when the Root certificate to validate the certificate is not on the server.

The authenticity is based on a Root certificate installed during the 3.60 software installation.

Please make a backup of this certificate. If you replace the server computer, you need to install the certificate on the replacement server to do the authenticity check.

The signing certificate is stored here: `\Program Files\Bosch\DICENTIS\<hostname> signing root authority.crt`.

To install the certificate on another computer, do the following:

1. Right-click the certificate and select **Install certificate**.
2. Select **Local machine**.
3. Select **Place all certificates in the following store**.
4. Select **Browse**.
5. Select **Trusted Root Certification Authorities**.
6. Select **Next**.
7. Select **Finish**.

Use Powershell to know if the certificate was successfully installed. Run the command `dir Cert:\LocalMachine\Root\`, and it should list the certificate.

7 Configuring DICENTIS for hybrid meetings

The DICENTIS Hybrid Meetings allows participants that are not physically present in the meeting room to join remotely using a web browser.

7.1 System setup

7.1.1 Licenses

Each participant needs a participant license to be able to join a meeting. Remote participants require a hybrid add-on license.

**Notice!**

It is not possible to mix prepaid and subscription licenses.

Up to 100 participants can join a meeting remotely. Currently, the video of 23 remote participants can be displayed simultaneously.

The set of functionalities available for a participant, both on-premises and remotely, depends on that participant's license.

For more information on the participant licenses, refer to the *License overview, page 20*.

7.1.2 Terms and conditions of use

The end customer needs to agree with the terms and conditions of use before using the DICENTIS Hybrid Meetings.

The system installer contacts Bosch to start the agreement process. Afterwards, the end customer receives and replies to an email accepting the terms and conditions of use.

7.1.3 Additional hardware

The computer running the DICENTIS services requires a second network adapter. No additional equipment is required if you use the software video switching of the DICENTIS system.

7.1.4 Network requirements

For hybrid meetings to run smoothly, the following requirements need to be met:

- Bandwidth for meeting room:
 - Upstream: 50Mbps or more
 - Downstream: 50Mbps or more
- UDP/TCP:
 - For hybrid meetings, UDP transport is strongly recommended for a good user experience. TCP transport increases audio and video latency to and from remote participants.
- PC requirements:
 - DCNM-SERVER3.
- Bandwidth for participants joining remotely:
 - Upstream: 5Mbps or more
 - Downstream: 20Mbps or more

7.1.5 Hall display and room cameras

You need to configure the Media Gateway so that the video of the meeting room can be shared with the remote participants and vice versa. The same applies to presentations.

7.1.6 Audio setup

The audio of the meeting room needs to be transmitted to the remote participants and the other way around.

– **To configure the audio for hybrid meetings:**

1. Set the audio of Dante Input 2 and Output 2 to Mix-Minus unprocessed and unmute them.
2. In the Dante Controller, create a multicast flow for the Floor of DICENTIS-<hostname PC>MG.
For more information, refer to the section on how to create multicast streams of the chapter *Configuring Dante™ compatible devices*, page 148.
3. Using the Dante Controller, route:
 - DICENTIS-<hostname PC> Dante Output Out 2 to DICENTIS-<hostname PC>-MG Floor
 - DICENTIS-<hostname PC>-MG Floor to DICENTIS-<hostname PC> Dante Input In2

Note: You need to download and install the Dante Controller software from Audinate.

7.2 Setup of remote participants

Before a remote participant can join a meeting, a person needs to be defined for that remote participant in the Meeting application. The same applies to participants that are present in the meeting room.

For remote participants to be able to log in the remote web application, you need to setup their credentials. A combination of **User name** and **Password** needs to be defined for each participant.

You only need to setup each person once. Refer to *Persons*, page 45 for more information.

7.3 Preparing a hybrid meeting

After a meeting has been setup, both the remote participants and the participants present in the meeting room need to be assigned to the meeting.

You can send the remote participants a link to the meeting so that they are able to join remotely. Each meeting has a unique link. The meeting link can be found next to the **Name** of the meeting on the Meeting details. For more information, refer to *Meeting details*, page 53.

The identification option set on the meeting details does not influence how remote participants identify themselves. Remote participants always need to log in using their credentials, even if using an NFC card is set as the identification mode, for example.

7.4 Managing a hybrid meeting

You need to activate a meeting through the Meeting application before the remote participants can log in. After the activation, it takes a few minutes for the login to become available.

You can check the status of the online cloud using the DICENTIS Webserver. The cloud icon in the DICENTIS Webserver appears when the online meeting is available for the remote participants. Hover over the cloud icon to see the state of the meeting.

The following status are possible:

Message	Icon color	Cause	How to fix
Meeting inactive	White	No prepared meeting is activated	n.a.
Cloud connection progress	White with turning wheel	A meeting is activated and the remote participation is prepared	Wait
Your connection for Hybrid meetings is fully tested and works OK, have a pleasant meeting	White	n.a.	n.a.
MissingCertificate	Red	The certificate that identifies the DICENTIS server to the cloud services does not exist	Use the DICENTIS activation tool to obtain a certificate
CertificateRefreshFailed	Red	The refresh of the certificate that identifies the DICENTIS server to the cloud services has failed	Use the DICENTIS activation tool to obtain a new certificate
CertificateExpired	Red	The certificate that identifies the DICENTIS server to the cloud services has expired. This can happen when the DICENTIS server is not connected to the internet for more than 4 weeks	Use the DICENTIS activation tool to obtain a new certificate
NoInternet	Red	There is no Internet access. This is tested by reading www.google.com	Fix the internet access

NoHybridServices	Red	There is Internet access, but the Bosch hybrid services cannot be reached	Call tech support
GeneralMultimediaFailure	Red	There is a problem with the audio/video transport. This problem applies to all participants	Call tech support
LocalMultimediaFailure	Red	There is a problem with the audio/video transport. Audio/video between remote participants might still work	Check that you can send UDP messages to the Internet and are not using a proxy
UpdateFailed	Red	Update of the DICENTIS Hybrid Meetings component of the local DICENTIS server has failed	Ensure that the DICENTIS server can access the Internet during the weekend

7.5 Joining a meeting as a remote participant

Before a remote participant can join a meeting, that meeting needs to be activated. By clicking the meeting link, the DICENTIS Hybrid Meetings page opens. When the meeting is available, the remote participant is asked to log in. If the meeting is not available, this information appears on the DICENTIS Hybrid Meetings page. As soon as the meeting becomes available, the login appears automatically. The participant does not have to refresh the page.

After logging in successfully, the audio and video devices need to be selected. It is possible that some audio and video devices are not available. This can happen when those devices are already in use by another AV application.

If a remote participant leaves a meeting with the microphone active, that participant remains in the speaker queue as a flying speaker. If the participant:

- Returns to the meeting, the flying speaker becomes a speaker.
- Does not return to the meeting, the clerk can remove the flying speaker by using the Meeting application or the Synoptic control.

If, for any reason, the microphone of a remote participant is switched on by the system, that participant is placed in the speaker queue with the microphone muted. The participant needs to unmute the microphone before speaking. This ensures that remote participants have control over their microphones at all times and protects the participants' privacy.

7.6 Automatic updates

The DICIENTIS services running on the server contain several components that are required for hybrid meetings. These components are automatically updated on a regular basis. A Windows task scheduler **Bosch -> DICIENTIS Hybrid** runs every Sunday at 3 AM (DICIENTIS server time) and every time the server starts up.

These automatic updates also apply to the Media Gateway that is used for video switching.



Notice!

During an update, the DICIENTIS services stop temporarily. This means a running meeting is deactivated. When the update finishes, the DICIENTIS services automatically restart. However, automatically deactivated meetings are not automatically activated again.

8 Configuring the Media Gateway

With the release of software 5.0 and availability of Premium and Ultimate licenses, Media Gateway is introduced as an advanced video management solution.

Media Gateway supports:

- 10 IP cameras
- 10 different views (cavasses)
- 3 different output streams
- Kramer MV6 and TV-One CorioMatrix SDI video switcher for single video
- Software video switching for:
 - Multiple video feeds in a video layout
 - IP video

This video switching functionality is available for DCNM-CRN, DCNM-DEMO, as well as the following licenses:

	Premium	Ultimate
Perpetual	DCNM-LPP-PE	DCNM-LPU-PE
Prepaid	DCNM-LPPP-P1Y	DCNM-LPUP-P1Y
Subscription	DCNM-LPPP-S1Y	DCNM-LPUP-S1Y

8.1 Components

The Media Gateway comprises different components:

1. **Input sources** - A maximum of 10 input sources can be defined: H.264 streams from cameras or encoders. Do not use resolutions above 1080p.
2. **Configuration** - Defines the behavior of the Media Gateway. Refer to the chapter *How to configure*, page 115 for more information.
3. **DICENTIS state** - Consists of the number of active microphones, as well as the presentations from participants present in the meeting room and joining remotely.
4. **Media Gateway**
5. **H.264 Outputs** - User-defined output streams in H.264 format, including overlay. In the configuration, you configure the content, resolution, conditions and behavior.
6. **Control output** - Controls the PTZ of the IP cameras, as well as the external SDI switchers Kramer MV6 and TV One CorioMatrix, if used.

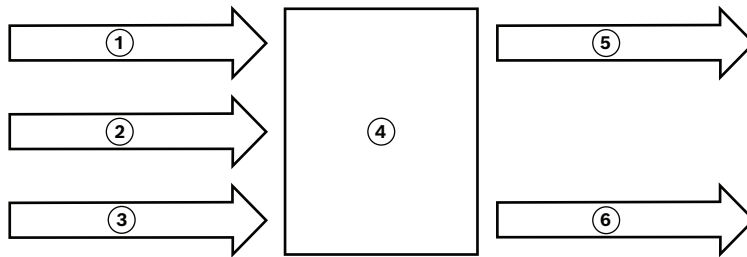

Figure 8.1: Functional explanation of the Media Gateway

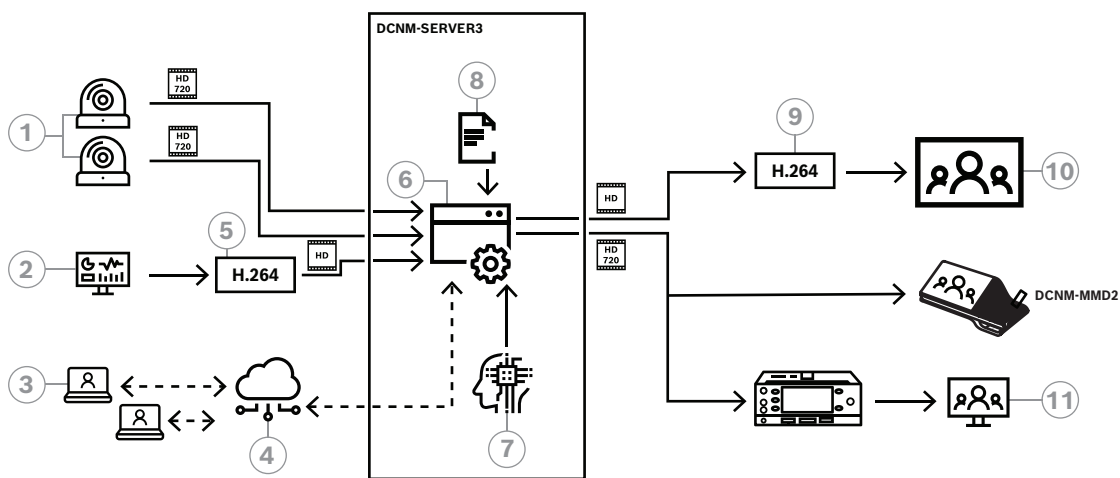

Figure 8.2: Media Gateway - Concept diagram

1	Cameras	2	Local presentation source
3	Remote participants	4	Bosch Cloud
5	H.264 encoder	6	Media Gateway
7	DICENTIS system state	8	Media Gateway configuration
9	H.264 decoder *	10	Monitor
11	Interpreter monitor		

* Optional software application (DICENTIS media player) running on client PC

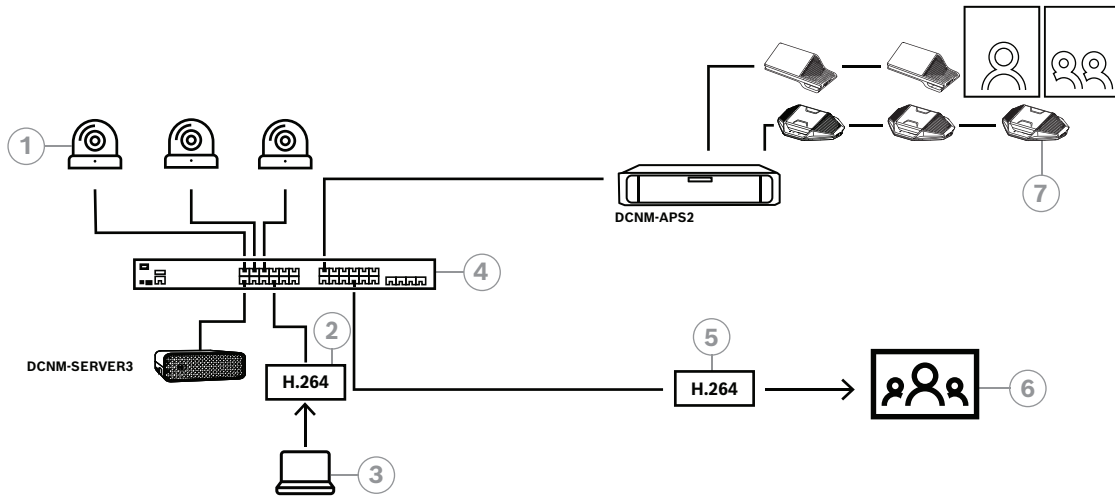

Figure 8.3: Standalone DICENTIS system using software video switching

1	Cameras	2	H.264 video encoder
3	Local presentation	4	Media Gateway
5	H.264 video decoder *	6	Monitor
7	Conference devices		

* Optional software application (DICENTIS media player) running on client PC

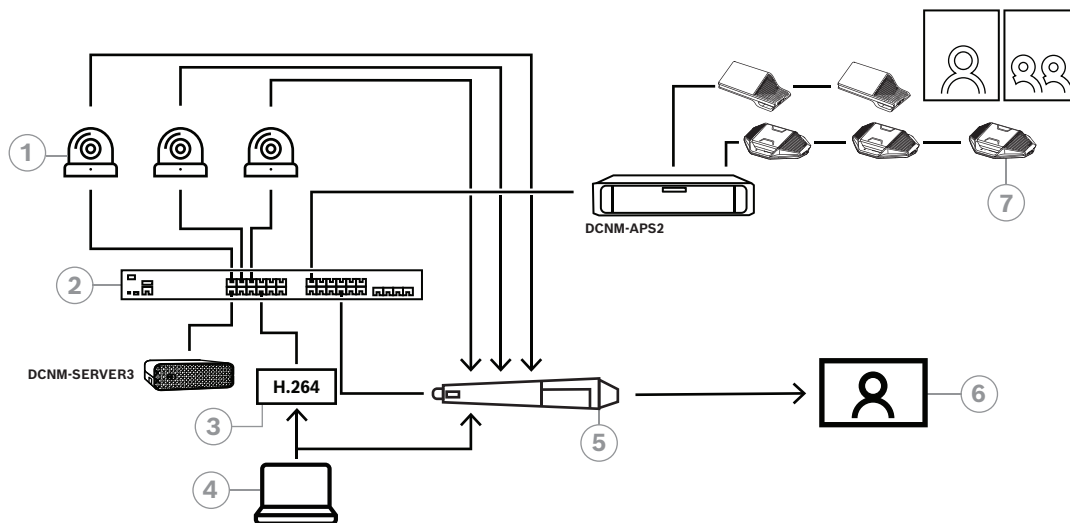

Figure 8.4: Standalone DICENTIS system using SDI hardware switching

1	Cameras with SDI outputs	2	Media Gateway
3	H.264 video encoder	4	Local presentation
5	External SDI switcher	6	Monitor
7	Conference devices		

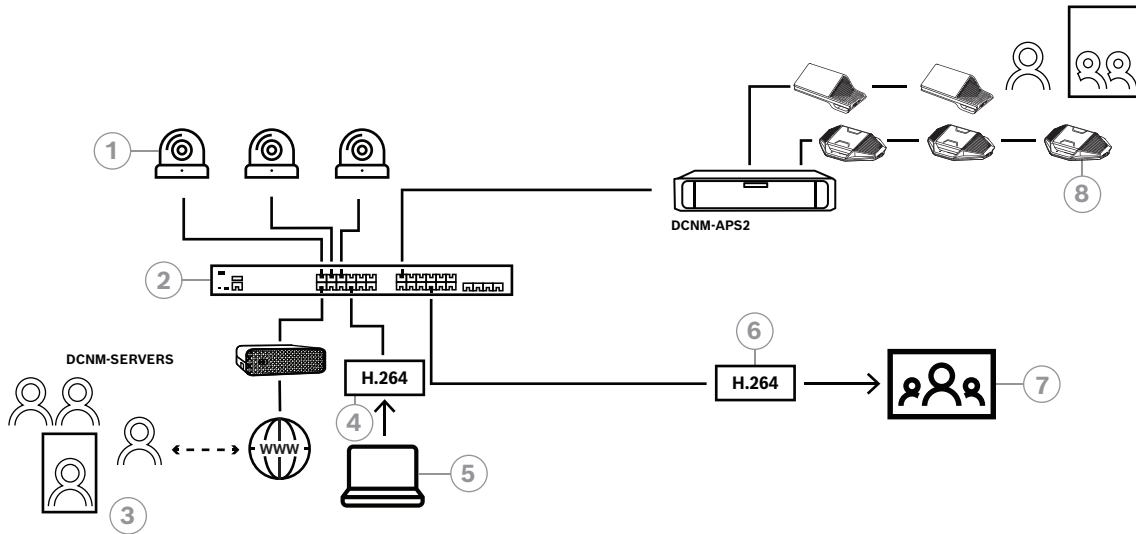

Figure 8.5: DICENTIS hybrid meetings using software video switching

1	Cameras	2	Media Gateway
3	Remote participants	4	H.264 video encoder
5	Local presentation	6	H.264 video decoder *
7	Monitor	8	Conference devices

* Optional software application (DICENTIS media player) running on client PC

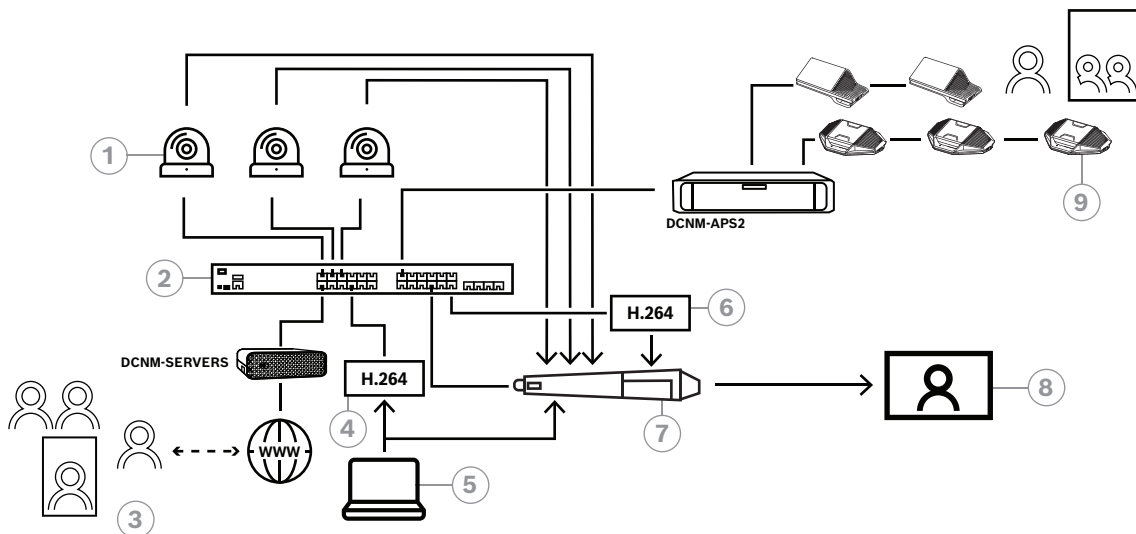

Figure 8.6: DICENTIS hybrid meetings using SDI hardware switching

1	Cameras with SDI outputs	2	Media Gateway
3	Remote participants	4	H.264 video encoder
5	Local presentation	6	H.264 video decoder *
7	External SDI switcher	8	Monitor
9	Conference devices		

* Optional software application (DICENTIS media player) running on client PC

8.2 How to configure

You configure the Media Gateway through a webpage. The link to access the webpage should have the following format: **https://<hostname or IP-address of the DICENTIS server>:31416/Mediagateway**.

To configure the Media Gateway, you need to have **Configure system** rights.

The webpage contains instructions on how to configure.

The configuration includes eight sections:

- **Inputs** - Define the cameras.
- **Seatmaps** - Define the seats and presets. A seat can have multiple combinations of camera/preset. Use the Center, Left, Right views to define from which angle the shot is made. This is used for a side-by-side video split.
Note: The seat names in DICENTIS need to be unique for the Media Gateway to work properly.
- **Video switcher** - Configure the SDI video switcher.
- **Canvases** - Define your video views. A video view can be single, split, quad, etc.
- **Contents** - Define when a Canvas is selected. For example, you can define that the Overview canvas is selected when nobody is speaking or that a split video view is selected when 2 participants speak.
- **Stream** - Define the output stream. You might want to use different encodings for recording and broadcasting or projecting on a large screen.
- **Configuration** - Here you find general settings: What is the stream for the local presentation, if camera override is used, etc.
- **Global settings** - Here you find global settings, such as the font, size and color of the overlay text.

9 System extension

The DICENTIS Conference System is scalable from small to medium to large. This section describes what a small, medium and large system is and what the requirements are for these systems:

A small to medium DICENTIS Conference System (see Typical system setup) consists of:

- up to 450 DICENTIS nodes.
Refer to table **Node and device count of DICENTIS equipment** below about the node and device count of DICENTIS equipment.
- all DICENTIS devices in 1 subnet.
- 1 DICENTIS Audio processor and powering switch for the audio processing.
- 1 Server PC which hosts the DICENTIS services.

A large DICENTIS Conference System consists of:

- up to 1500 DICENTIS devices.
- multiple subnets connected by use of a router/L3 switch.
 - Each subnet can have up to 450 DICENTIS nodes.
Refer to the following table for the node count of DICENTIS equipment.
 - The first subnet has:
 - 1 DICENTIS Audio processor and powering switch for the audio processing.
 - 1 Server PC which hosts the DICENTIS services.
 - 1 ARNI-Enterprise to increase the size of the system.
 - All other subnets have 1 ARNI-Standard to increase the size of the system.

Note: There is no DICENTIS Audio processor and powering switch in the other subnets.

Device	Node count	Device count	IP addresses
DICENTIS Server	0	0	1
DICENTIS meeting application	0	0	0
DICENTIS Audio processor and powering switch	1	1	1
DICENTIS Powering switch	1	1	1
DICENTIS Multimedia device	2	1	2
DICENTIS Discussion device	1	1	1
DICENTIS Discussion device select language	1	1	1
DICENTIS discussion device voting	1	1	1
DICENTIS Discussion device extended	1	1	2
DICENTIS Interpreter desk	1	1	2
DICENTIS Interpreter desk with video	1	1	3
DICENTIS Flush base device 2	1	1	1
DICENTIS Flush language selector	1	1	1
INT-TXO Transmitter OMNEO	1	1	2
OMN-DANTEGTW Dante gateway	1	0	1
PRS-4OMI4 OMNEO media interface	1	0	1

Device	Node count	Device count	IP addresses
OMN-ARNIE ARNI-E OMNEO interface	0	1	1
OMN-ARNIS ARNI-S OMNEO interface	0	1	1

Table 9.1: Node and device count of DICENTIS equipment

A large system with more than 450 nodes requires an ARNI (Audio Routed Network Interface). For the system setup, refer to System extension in the Hardware Installation Manual.

An ARNI (Audio Routed Network Interface) is used to connect multiple DICENTIS system subnets. If more than one subnet is required, two types of an ARNI must be used.

- OMN-ARNIS (ARNI-S OMNEO interface): The ARNI-S is required for increasing the system size above 450 DICENTIS nodes. It supports up to 450 DICENTIS nodes in its subnet. It also acts as a DHCP server in its subnet.
- OMN-ARNIE (ARNI-E OMNEO interface): The ARNI-E is required for increasing the system size above 450 DICENTIS nodes. It supports up to 450 DICENTIS nodes in its subnet. It also acts as a DHCP server in its subnet. It can connect up to 40 subnets, each with an ARNI-S.



Notice!

Redundant ARNI is not supported in the DICENTIS Conference System.



Notice!

A detailed description of the ARNI is available in the ARNI manual on www.boschsecurity.com > DICENTIS product related information.

DICENTIS Conference System subnet and ARNI preconditions

- When multiple subnets are used, the subnet in which the DICENTIS PC server is present requires an ARNI-E, the others require an ARNI-S.
- The ARNI Configuration Tool must be used, which can be found in the start menu after installing DICENTIS system server software.
- When configuring ARNI's, make sure that the DICENTIS server PC services are not running. Stop the services using the server console.
- When configuring ARNI's, connect the ARNI directly to the PC (without a (managed) switch in between).
- When setup a multi-subnet configuration, attach each ARNI to the PC one by one to configure it.

Configuration of an ARNI

1. If required/requested, upgrade the ARNI with the OMNEO firmware upgrade tool to the firmware version as already available/installed by the DICENTIS system setup.
2. Start the ARNI Configuration Tool.

3. Follow the wizard steps of the ARNI Configuration Tool to configure the ARNI(s).
Furthermore:
 - The type of ARNI is always primary when you are not working with redundancy.
 - Name each ARNI, especially if more than one ARNI is used within the system.
 - Make sure that the IGMP querier is disabled.
 - Enable DHCP for every ARNI.
 - If the IP address of an ARNI must be changed: reset the ARNI to factory default with the ARNI Configuration Tool. Use the function “restore factory defaults”.

Configuration of a switch with VLANs

When configuring a switch with VLANs, ensure the following:

- Use the ARNI as the DHCP server for all VLANs that will contain DICENTIS devices, DCNM-APS and DCNM-PS units. For other VLANs, you may use any other DHCP server.
- Enable IGMP snooping on all ports.
- Enable multicast routing between all VLANs. Use “dense-mode” routing mode.
- Configure unicast routing correctly between all VLANs.
- Use MTU 1500 or larger.
- Enable spanning tree protocol to mode “pvst”.
- Use IGMP version 3.
- Set Timeout of register on multicast to 1 second.

10 Configuring an IDESK (directly on the device)

To configure the DCNM-IDE SK / DCNM-IDE SKVID on the device itself, press the B - B buttons *at the same time*. The **B - B** buttons (input channel B and output channel B) are located on both sides of the display and can be easily recognized by the small raised dashes. The configuration pane opens with these options:

- **Booth No. - Desk No.:** To assign a device to a booth and a desk within that booth. If you assign a desk to a number that has already been used, the previous booth - desk combination will be overwritten by the new desk.
Note: When you connect a new desk to a DICENTIS system, it will not be assigned automatically, but you have to configure it via the **B - B** buttons on the desk or via the Meeting application/API. When a desk is connected that was connected before, it will return to its original booth and desk number.
- **Available languages:** Offers you the possibility to configure the number of languages and which languages are available. Use *Language selection, page 76* to determine which languages are available.
- **Output A + B + C:** Select the language for the A output (usually the language the interpreter interprets to) and the languages for the B and C outputs (from the list of available languages).
- **Display brightness:** Adjust the brightness of the display by pressing the button (1 - 15) and using the rotary control. The default value is 7.
- **Auto configure desks:** Automatically configures all interpreter desks in the system. This means the A output will be set to the language that corresponds to the booth number. The B and C outputs will be set to none and the 7 pre-select buttons for the input languages will be configured as 1st button - 1st language, 2nd button - 2nd language, and so on.
- **System information:** Shows system information for the interpreter device and OMNEO (firmware version, IP address, etc.).
- Click the Exit button at the lower right side from your display to exit each of the above menu options.
Note: All changes made in the configuration on the Interpreter desk are directly visible in the Meeting application in real-time. For this reason, they may have an impact if there is an active meeting going on. Therefore, do not change the configuration while there is an active meeting.
Note: For instructions on how interpreters should operate the interpreter desk, please refer to the Quick user guide that is provided separately for the DCNM-IDE SK / DCNM-IDE SKVID.

11 Configuring an external HD-SDI switcher

Background information

An external video switcher service can be added to the DICENTIS Conference System for dynamically switching HD-SDI video signals. This enables video signals from a Dome camera to be displayed with low latency on a hall-display.



Caution!

To ensure that the third-party video switcher works correctly, the switcher service must be correctly configured.

11.1 Hardware and software requirements

- Server PC running the DICENTIS software.
- **Bosch DICENTIS Ext.VideoSwitcher** service installed on the server PC.
- DCNM-LCC DICENTIS Camera Control license.
- HD-SDI switcher: the following switches are supported:
- TvOne C2-2355A in combination with TvOne S2-108HD.
- Kramer MV-6.
- TvOne CORIOmatrix.
- TvOne C2-2355A and Kramer MV-6 only: Network switch that filters multicast data towards the HD-SDI switching equipment (the preferred way is by creating a separate VLAN).
- Only one HD-SDI video switcher is supported per system.



Notice!

To control an HD-SDI video switcher, the External Video service must be installed first. This service is part of the DICENTIS setup wizard. During installation, make sure the checkbox for “Bosch DICENTIS Ext.VideoSwitcher” is selected - this checkbox is not selected by default! After the service has been installed, it must be configured.

11.2 Configuration Procedure

The External Video service works on three main inputs:

- HD-SDI Switcher details
- Presentation source input details
- Camera details

To configure these inputs:

1. Use an XML editor to open the following file:
C:\Program Files\Bosch\DICENTIS\Configuration\Config.xml
2. In the switcher section, configure the connection to the HD-SDI switcher you are using. Take care not to remove parts of the configuration file. Refer to the following example:
 - VideoSwitchers Model can be “**TvOne**”, “**Kramer**” or “**TvOneCorioMatrix**”.
 - VidSwitchPort is the port number of the Video switch.
For TvOne and TvOneCorioMatrix this is **10001** by default.
For Kramer this is **5000** by default.
 - VidSwitchIPAddress, e.g. **192.168.0.80**, is the IP address of the switcher.

- VidSwitchUserName is the administrator username (admin) of the switcher (only used for TvOneCorioMatrix).
- VidSwitchPassword is the administrator password (adminpw) of the switcher (only used for TvOneCorioMatrix).

```
<VideoSwitchers Model="TvOne">

  <VideoSwitcher>

    <VidSwitchPort>10001</VidSwitchPort>

    <VidSwitchIPAddress>192.168.0.80</VidSwitchIPAddress>

    <VidSwitchUserName></VidSwitchUserName>

    <VidSwitchPassword></VidSwitchPassword>

  </VideoSwitcher>

</VideoSwitchers>
```

3. If there is a presentation source, e.g. **RGB**, enter the presentation source input between **<VideoSwitchInput>**, as shown in the following example. Do not remove **<PresentationConfig>** if there is no presentation source.
 - TvOne supports two presentation inputs: **RGB**, and **DVI**. **None** can also be entered.
 - RGB**: Presentation is taken from the VGA port.
 - DVI**: Presentation is taken from the DVI port.
 - None**: No presentation (the video switcher will not switch to the presentation source during presentation mode but will continue to display the camera image instead).
 - Kramer does not have a VGA or DVI input, so **None** should be entered when a Kramer MV-6 is used.
 - TvOneCorioMatrix supports **None** or a specified input such as: **Slot_<X>_in_<Y>**. For example: **Slot_5_in_1** (for input 1 of the SDI input card which is inserted in slot 5).

```
<PresentationConfig>

  <PresentationSources>

    <VideoSwitchInput>RGB</VideoSwitchInput>

  </PresentationSources>

</PresentationConfig>
```
4. The system will detect the available cameras, and add the details to the config file, as shown in the following example:
 - <CameraId>, <CameraName> and <CameraState> are read only values that are generated by the system. Do not modify these values!
 - <CameraState> lists:
 - True**: When there is an Active speaker and Presentation is InActive.
 - False**: No: Active speaker and Presentation is Active.
 - <VideoSwitchInput> contains the input on which the camera is located:
 - 1 to X** (numeric) for the TvOne and Kramer model.
 - Slot_<X>_in_<Y>** for the TvOneCorioMatrix.

For Example: **Slot_5_in_1** (for input 1 of the SDI input card which is inserted in slot 5).

```
<CameraConfig>
  <Camera>
    <CameraId>99bfb876-59eb-39af-9d3b-b64d0cbc4957</CameraId>
    <CameraName>044000110225010081</CameraName>
    <VideoSwitchInput>1</VideoSwitchInput>
    <CameraState>false</CameraState>
  </Camera>
  <Camera>
    <CameraId>9939afb876-39af-59eb-9d3b-b64d0cbc4587</CameraId>
    <CameraName>0440240110225012382</CameraName>
    <VideoSwitchInput>2</VideoSwitchInput>
    <CameraState>false</CameraState>
  </Camera>
</CameraConfig>
```

5. When the External Video Switcher is used in combination with TvOneCorioMatrix, an output must also be configured, as shown in the following example:
 - Do not remove <OutputConfig> if you are using another switcher model.
 - <VideoSwitchOutput> describes the output of the TvOneCorioMatrix in a specific way, such as **Slot_<X>_out_<Y>**.

For example: **Slot_3_out_1** (for output 1 of the SDI output card which is inserted in slot 3).

```
<OutputConfig>
  <Output>
    <VideoSwitchOutput></VideoSwitchOutput>
  </Output>
</OutputConfig>
```



Notice!

If switcher information, such as switcher model, IP port has changed, a restart of the External video-switcher service is required.

12 Conference protocol

The Conference protocol is a platform-independent protocol. It is based on WebSocket technology to enable scalability, on HTTPS to ensure increased security, and on JSON to allow it to be platform independent.

You can find the documentation for the Conference Protocol (ConferenceProtocol.chm) in the Docs directory of the delivery. It is also by default in C:\Program Files\Bosch\DICENTIS\ConferenceProtocol.chm.

Requirements

The Conference protocol connects to the DICENTIS webserver.

Requirements for the DICENTIS webserver:

- To manage the discussion: manage meeting
- To power on/off the DICENTIS system: power off functionality
- To control the master volume of the DICENTIS system: volume control functionality

There is an online demonstrator available, which can be accessed via: <https://<ipaddress>:31416/Demonstrator/ConferenceProtocolDemonstrator.html>:

1. Login with a DICENTIS user. When a meeting is active, you can also login with a participant username.
2. Use the F12 button on your browser to access the console view and see the communication.
3. Use the Debugger view and browse to Demonstrator/Controllers: conferenceServices.js gives you an overview of commands and context.

Note: you can also find the source code of a Linux based demonstrator "ConferenceProtocolDemonstrator.zip" in the Tools directory.

13 System Activation Website

The main purpose of the System Activation Site website (<https://license.boschsecurity.com>) is to manage all modifications to your system, e.g. activate DICENTIS licenses, as described in *Initial activation of the system, page 140*.

This website can also be used to:

- Add/remove licenses.
- Select the system via manage devices.
- Upload response files.
- Download license files.
- View received (activated and not activated) licenses.
- Create and maintain users.
- Create and maintain (sub)dealers.

User rights are assigned to the following types of user during log in:

- **Admin user:** can modify user and dealer accounts; cannot access the **Manage devices** and **Manage license** pages.
- **Logistics user:** can assign orders to a dealer; cannot access the **Manage devices**, **Manage license**, **Manage users**, and **Manage dealers** pages.
- **Technician:** can activate, return, and repair fulfillments; cannot access **Manage users** and **Manage dealers** pages.

To access the website:

1. Enter: <https://licensing.boschsecurity.com/StartPage.aspx> in your web browser. The following page is displayed:



Figure 13.1: System Activation Site Login page

2. Use the drop-down list at the top left-side of the page to select the required language.
3. Click **Login** and enter your e-mail address and password.
4. Click the blue **Login** button. The **Overview** page is displayed.

Note: If you forgot your password, a new password can be requested by clicking **Login > Forgotten your password?**

13.1

Overview

After logging in, the **Overview** page is displayed by default. This page shows the activated and non-activated “activation IDs” delivered to your organization.

- Click the blue left/right arrows on the right side of the page to display the next or previous page
- Click the blue up/down arrows at the top of the columns to change the alphabetical sequence of the Sales orders.

Search for orders

Use the **Search for Orders** field to find an existing order. To do this:

1. In the **Enter the search text** field, enter the order number.
2. From the **Search For** drop-down list, select **Sales order**.
3. Click **Search**. The search results are displayed.

Sales order

Click one of the blue hyperlinks in the **Sales order** column to display the **Order details**.

- **Order number:** The order number from the **Sales order** column (read only).
- **Create date:** The date the order was created (read only).
- **Assign order:** Use this feature to assign a license to a dealer in your organization (the organization has to be created before you can do this). Technicians can only activate licenses that have been assigned to their organization. Licenses are assigned to organizations to prevent them from being lost:
 - **Select Dealer:** Selects the dealer that you want to assign the order to.
 - **Dealer ID:** Unique identification number for the dealer (read only).
 - **Assign order** button: Assigns the order to the selected dealer (requires Logistics user rights).



Notice!

You can only assign orders that are not in use.

In use

If an order is in use, > yes appears on the respective column. When you click on > yes, the **System details** are displayed. Click the **Navigate to Device Details** button to go to the **Manage Devices** page.

Dealer

The name of the dealer.

Location

Click one of the blue hyperlinks to display the **System details**. A system can contain multiple Sales orders (licenses can be added as required).

The following information, but not exclusively, is displayed: location of the installed system, address, activation date of the system software, and expiration date of the Software Maintenance Agreement.

Customer

The name of the customer.

City

The city where the customer is located.

Activation ID

The activation ID for activating the license.

Activation date

The date the license was activated.

13.2

Manage devices

Precondition

- To use this page, the logged in user must have the user right “Technician”.

Use the Manage devices page to select your system, add and return licenses and upload and download response files.

You can search for different devices via the search box. You can search for device ID, account name, account ID and activation ID. You find these options in the dropdown bar

Search for. Click the **Search** button to proceed with your search.

Select your desired device by clicking the hyperlink in the Device ID column.

Notice!

If you have been provided with a specific device ID, it is crucial to input it accurately when referencing a particular device in the system. Any variations or deviations from the assigned ID may result in misidentification and potential errors in the processing.

You can also utilize the asterisk (*) as a wildcard character to represent any combination of characters.

Note that the wildcard (*) can only be used as a substitute for a sequence of characters within the device ID, not a replacement for individual characters within the ID.

**To add licenses to your system:**

- After selecting your desired device, click in the **Add Licenses** button.
- Select the license(s) you want to activate from the list by checking the correspondent checkbox and press OK to confirm.

Notice!

The DICENTIS server is then synchronized with the activation via the **Refresh** button on the activation tool (online mode) or via the processing of the response file in the activation tool (offline mode).

**To return licenses from your system:**

- After selecting your desired device, click in the **Return Licenses** button.
- Select the licenses you want to return from the list by checking the correspondent checkbox and press OK to confirm

Notice!

The DICENTIS server is then synchronized with the activation via the **Refresh** button on the activation tool (online mode) or via the processing of the response file in the activation tool (offline mode).

**To upload the response file:**

- After selecting your desired device, click in the **Upload response file** button.
- Upload the **bin** file and click **Process** to process it.

To download the license file:

- After selecting your desired device, click in the **Download license file** button to download a **bin** file to your device.

To assign the system to another account:

- After selecting your desired device, click the pencil icon in the **Account Id** field to assign the system to another account.

13.3 Manage license

Precondition

- To use this page, the logged in user must have the user right “Technician”.

Use the Manage license page to activate, return, and repair fulfillments.

Choose file

Use this button to select the required **xml/bin** file.

Process

Use this button to process the selected **xml/bin** file.

13.4 Manage users

Precondition

- To use this page, the logged in user must have the user right “Admin user”.

Use the **Manage users** tab to manage user accounts for other users so they can access the website and activate licenses. As an admin user you can manage all user accounts. You cannot delete your own account.

Each account can have:

- Multiple admin users,
- Multiple logistic users,
- Multiple technician users.

NOTE: A user can have multiple roles.

Create user

Click this button to create a new user. Complete the mandatory fields for First name, Last name, Country, and E-mail address.

Select the rights that this user account will have by checking the boxes on Technician, Admin or Logistics (more than one role can be selected for one user account). Once completed, this information is displayed in the columns on the **Manage users** page, and the check box in the column for the correct role(s) rights is selected.

Edit

Click the hyperlink in the **E-mail address** column to change the First name, Last name, and Country of the user. Click **Save** or **Cancel** to store or discard the settings.

Delete

Click this hyperlink to delete the selected user account. You cannot delete your own account. A dialog box will be displayed asking you to confirm this action.

13.5 Manage dealers

Precondition

- To use this page, the logged in user must have the user right “Admin user”.

Use the **Manage** dealers page to view and manage the information of (sub)dealers. This page is normally used by a Bosch Dealer to assign orders to (sub)dealers. As an Admin user, you can create (sub)dealers and create Admin users for the (sub)dealer. Those Admin users can then create users with Admin or technician roles.

NOTE: The user management for the (sub)dealer is the responsibility of the Admin user(s) of the (sub)dealer.

Create dealer

Click this button to create sub-organizations that can have activation IDs (Sales orders) assigned to them. These sub-organizations can only see:

- the activation IDs that have been assigned to them.
- the systems they have installed.

Orders are assigned to (sub)dealers on the Overview page. See Overview.

Complete the mandatory fields for: Dealer ID, Dealer name, First name, Last name, User name, and Email. Once completed, the Dealer ID, Dealer name, Admin user name, and Admin email address are displayed in the columns on the **Manage dealers** page.

Dealer ID

Click one of the blue hyperlinks in the **Dealer ID** column to change the Dealer name or the Admin details. Click **Save** or **Back** to store the settings or return to the **Manage dealers** page.

14 System server

The DCNM-SERVER System server uses standard HP Z2 Mini G4 hardware. Refer to the HP Z2 Mini G4 hardware manuals at <https://support.hp.com/us-en/product/hp-z2-mini-g4-workstation/19968625/manuals>.

The DCNM-SERVER2 System server uses standard HP Z2 Mini G5 hardware. Refer to the HP Z2 Mini G5 hardware manuals at <https://support.hp.com/us-en/product/hp-z2-mini-g5-workstation/34407176/manuals>.

The DCNM-SERVER3 System server uses standard HP Z2 Mini G9 hardware. Refer to the HP Z2 Mini G9 hardware manuals at <https://support.hp.com/us-en/product/hp-z2-mini-g9-workstation-desktop-pc/2101025774/manuals>.

The DICENTIS System server is delivered with Windows pre-installed and pre-configured with the DICENTIS software.



Notice!

The DICENTIS System server is not marketed as a general purpose computing device (such as a personal computer) or a general purpose server, or a commercially viable substitute for one of these systems.

The primary function of the DICENTIS System server is hosting the DICENTIS services. Additional software added by a third party software provider cannot provide nor replicate the primary function of the DICENTIS System server.

Connecting to the server PC via Remote Desktop Connection

Use the Remote Desktop Connection application to connect to the server PC and make the necessary configurations:

1. Open the Remote Desktop Connection application.
2. Type the server PC IP address and click Connect.
3. Enter the user's password and click OK.



Notice!

The default password can be found on the device. For security purposes it is advised to change the default password to a new password.

While logged into a Remote Desktop session, press the <CTRL> + <ALT> + <END> key combination. This will launch the task menu on the remote server instead of on your local PC. Select the Change a password option to change the default password.

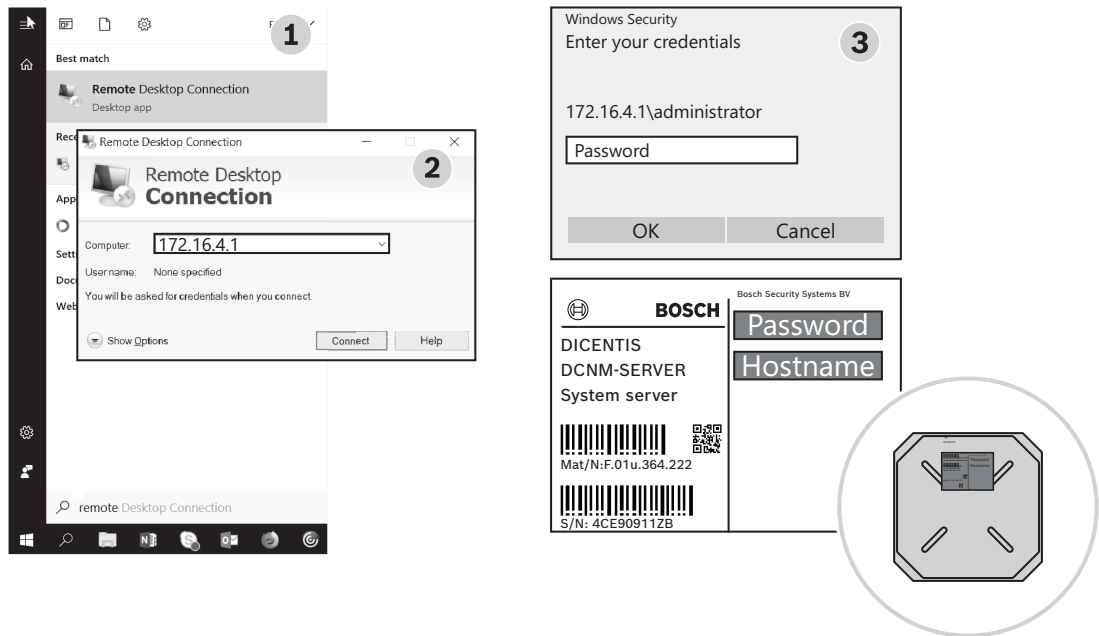

Figure 14.1: Remote Desktop Connection



Notice!

You can also connect to the computer via the hostname (if your Office network is configured properly). The hostname of the DICENTIS server is on the label on the bottom of the device. It is similar to: DICENTIS-*<last 3 byte of the MAC-address of the Ethernet adapter on the DICENTIS side>*. Connecting via the hostname is more reliable since IP addresses can change.



Notice!

Please keep your system up to date with the latest Windows updates and an up to date virus scanner. The office network port can be used for this purpose. You must also adjust the date and time in the Windows settings so that Windows updates and power cycling are performed when the system is not used. Windows updates are scheduled, via the Windows Task Scheduler, for Sunday morning at 1 AM. The update task is configured to automatically reboot the computer after the updates, if required.

Once logged in, perform the following steps:

1. Set the correct time zone by adjusting the Windows date/time settings.
2. Upgrade the devices to the latest version. See *Downloading software to the devices*, page 27.
3. Activate the DICENTIS System Server Software (DCNM-LSYS) license. See *License requirements*, page 19.

Note: The DICENTIS software installed out of factory might not be the most recent version. Please refer to chapter 4.1 about downloading and installing the latest version.

**Notice!**

User data can be present in the database, the voting and meeting notes and the participant images. Please clear all user data of the DICENTIS server when you decommission the DICENTIS server. Refer to *Remove unused images, page 152*.

14.1 Creating a backup on the server

The Windows Server Backup application is installed and a shortcut is available on the desktop. This application can be used to create a backup of the system, including configuration and DICENTIS licenses, after the system is fully configured. This image can then be restored when problems occur with the configuration of the system or when the storage media drive is replaced.

To create a backup:

1. Double click the Windows Server Backup application icon on the desktop to start the application
2. Select **Backup Once...**
3. Select **Full server**
4. Create your backup on an external media drive (e.g. USB or network drive) with a capacity of at least 32 GB.

14.2 Restoring the factory image of the server

Restore the factory image of the DICENTIS server to return to the out of the box default state.

**Notice!**

Restoring the factory image will remove all user data on the DICENTIS server.

* Return the license before restoring the factory image so that the license can be activated afterwards.

* Backup the database and store it on an external device so that you can restore it after restoring the image.

To restore the factory image:

1. Connect a keyboard, monitor and mouse to the DICENTIS server
2. Power up the DICENTIS server and press the F8 key when "Protected by HP Sure Start" is displayed to enter the Windows Advanced Boot Options mode
3. Select **Repair your computer**
4. When **Choose an Option** is displayed, select **Trouble shoot and System Image Recovery**.
5. Follow the on-screen instructions.

Note: The factory image is located on the Recovery drive.

15 Dante gateway

The Dante gateway is used to interface the DICENTIS system with other systems via Dante™ and when unicast Dante™ streams or glitch free mode is required.

It has an OMNEO side with 2 Ethernet connectors for redundancy purposes, and a Dante™ side also with 2 Ethernet connectors for redundancy purposes.

The Dante gateway:

- Combines multiple OMNEO devices into a single Dante™ interface.
- Receives 64 Dante™ streams and sends them as 64 OMNEO streams, of which 16 can be encrypted.
- Receives 64 OMNEO streams, of which 16 can be encrypted, and sends them as 64 Dante™ streams.
- Converts multiple OMNEO encrypted flows with a single unicast or multicast stream into a Dante™ flow with multiple unicast or multicast streams.
- Supports static routing with Dante Controller on the Dante™ side and dynamic routing (AES70) on the OMNEO side.
- Allows glitch-free redundancy on the Dante™ side and RSTP redundancy on the OMNEO side.
- Enables use of Dante Domain Manager™ in combination with OMNEO systems.



Notice!

When OMNEO inputs or outputs 17 to 64 are used, these streams will be automatically set to unencrypted mode by the DICENTIS system.



Notice!

The Dante gateway needs to be upgraded with the firmware delivered with the DICENTIS system. The Firmware upload tool can be used to upload the correct firmware both on the DICENTIS side and on the Dante™ side.

To configure the OMNEO side, use the Meeting application:

1. Open the Meeting application
2. Go to **Configure > Rooms > Floor and language routing**

See *Floor and language routing*, page 85 for detailed information.

To configure the Dante™ side, use the Dante Controller or the Dante Domain Manager™. Use OMNEO Control for configuring the network mode at the Dante™ side. Please refer to the OMNEO Control manual for more information. Download both OMNEO Control and the manual can at: <https://licensing.boschsecurity.com/omneo>.



Notice!

An OMN-DANTEGTW can receive up to 16 streams coming from the same transmitter stream. If it receives 17 or more streams all coming from the same transmitter stream, then no stream will be audible.

16 Hints and Tips

This Chapter gives information on:

- *Changing NetTime options, page 133*
- *Configuring secretary's PC for use in other VLAN as DICENTIS server, page 134*
- *Disabling control encryption, page 134*
- *Create a backup of the database, page 135*
- *Restore a database, page 135*
- *Updating a database to the current version, page 135*
- *Creating a clean database, page 136*
- *Deleting a database, page 136*
- *Connecting DICENTIS to a (remote) SQL server, page 136*
- *Downgrading DICENTIS software to a previous version, page 138*
- *Downgrading 4.1 or later DICENTIS software to a 4.0 or earlier version, page 139*
- *Installing the image server on a different computer, page 143*
- *Recovering devices from fail-safe mode, page 144*
- *Replacing a defective device, page 144*
- *Uploading and accessing files, page 144*
- *Configuring the date and time format of the DICENTIS Multimedia device, page 146*
- *Using a fixed IP address for the DICENTIS server in a DICENTIS system with ARNI support, page 146*
- *Selecting a network interface to work with DICENTIS, page 147*
- *Powering down the server via the power button, page 147*
- *Camera and presentation streams, page 147*
- *Making a backup and restoring your Synoptic configuration, page 148*
- *Configuring Dante™ compatible devices, page 148*
- *Setting a PIN code for a Dante™ device, page 149*
- *Adding a third-party application to a device, page 149*
- *Adding additional keyboards to a device, page 150*
- *Keeping third-party android apps on top on the multimedia device when changing agenda items, page 150*
- *Creating certificates using the command line tool, page 151*
- *Remove unused images, page 152*
- *ONVIF Camera discovery, page 152*
- *Secure login in the .net API for API applications (including Synoptic), page 152*
- *Renewing the registration of the tablets, page 153*

16.1 Changing NetTime options

NetTime is used to synchronize timers used in the DICENTIS Conference System. If the DICENTIS Conference System is used in a corporate environment, you might have to change the NetTime options.

To change these options:

1. Right click the **NetworkTime** icon in the notify area, and select **Properties -> Settings...**
2. Enter the correct Hostname or IP Address of the Time server in your environment.
Normally the time server is the same server as the DHCP server. Consult your local IT department for more information.
3. Click **OK**.
4. Click **stop**, and then click **start** to activate the new settings.

NOTE: Remember to change the service Windows Time to **Automatic** after uninstalling NetTime.

16.2 Configuring secretary's PC for use in other VLAN as DICENTIS server

Background information

The secretary (or clerk) should use the Meeting Application on his/her PC to prepare meetings. If the secretary's PC is in a different VLAN than the DICENTIS server, the Meeting Application cannot find the DICENTIS server. This is because the DICENTIS devices and the Meeting Application use the DNS-SD protocol, which does not work between different VLANs.

If necessary, the technician should use the following procedure to configure the Meeting Application on the secretary's PC so that it can communicate with the DICENTIS server.

Procedure

At the secretary's PC:

1. Ping the DICENTIS server:
 - Click the **Start** logo.
 - Type **command** in the search field, and then choose **Command Prompt** under **Programs**.
 - Type **ping** [hostname of the DICENTIS server].
 - Press **Enter** to ping the DICENTIS server.
2. If you are unable to ping the DICENTIS server, you might require assistance from your local IT department. If you still cannot ping the DICENTIS server, the IP address can be used instead. However, this is not preferred because IP-addresses may change.
3. Create a shortcut of the Meeting application on the desktop (use the **Bosch.Dcnm.UserInterfaces.MeetingManager.exe** file from the **C:Program Files (x86)BoschDICENTIS directory**).
4. Right-click on the shortcut, and select **Properties**.
5. In the shortcut tab, update the target, by adding the server that the PC needs to connect to:
 - **Usage:** **Bosch.Dcnm.Userinterfaces.MeetingManager.exe** [/server 'servername']
/server Optional parameter with the hostname or IP address of the DCNM server
 - **Example:** **Bosch.Dcnm.Userinterfaces.MeetingManager.exe /server COMPUTERTNAME.network.com**
6. Double-click the shortcut. You will be able to connect to the remote server from the Meeting application.

Additional information

- **/window:** Starts the meeting manager in a window (instead of full screen).
- **/?:** Displays a message box with the description of the command line arguments.

16.3 Disabling control encryption

Control encryption can be disabled using the following procedure:

1. Edit the following file: **Bosch.Dcnm.Services.DeviceService.Main.exe.config** located in: **C:\Program Files\Bosch\DICENTIS**
2. Change:

```
<add key="OcpControlSecurityForced" value="true"/>
```

 Into:

```
<add key="OcpControlSecurityForced" value="false"/>
```

3. Use the server console to restart the services.
 4. Change:

```
<add key="OcpControlSecurityEnabled" value="true"/>
```

Into:

```
<add key="OcpControlSecurityEnabled" value="false"/>
```
 5. Use the Meeting application to turn off the system.
 6. Use the server console and power to restart the services.
 7. Use the Meeting application to turn on the system.
- To enable control encryption, set the values to true again and restart the services.

16.4 Create a backup of the database

1. Stop the DICENTIS services using the DICENTIS Server Console.
 2. Open a command prompt in **Administrator mode**.
 3. Go to **C:\Program Files\Bosch\DICENTIS**.
 4. Run **DcnmDatabaseConsole.exe -b**.
The backup will be stored in **C:\Program Files\Microsoft SQL Server\MSSQL15.SQLDICENTIS2019\MSSQL\DATA\DcnmBackup**.
 5. Restart the DICENTIS services using the DICENTIS Server Console.
- Note:** For a different location or name of the backup please use this command: **DcnmDatabaseConsole.exe -b [filename and location]**. If the file already exists, the file will be extended with the latest backup.

16.5 Restore a database

1. Stop the DICENTIS services using the DICENTIS Server Console.
2. Open a command prompt in **Administrator mode**.
3. Go to **C:\Program Files\Bosch\DICENTIS**.
4. Run **DcnmDatabaseConsole.exe -r <filename and location of the database>**.
Note: Only *.bak files made by creating a backup can be restored.
Note: The restore command does *not* update the database to the current version. To update it to the current version, refer to Updating the database to the current version.
Note: An error notification will appear if your backup is in the **C:\Program Files\Microsoft SQL Server\MSSQL12.SQLDICENTIS2014\MSSQL\DATA\DcnmBackup** or in the **C:\Program Files\Microsoft SQL Server\MSSQL10_50.SQLEXPRESS\MSSQL\DATA\DcnmBackup** directory, because the SQL2019 has no access to these SQL2014 or SQL2008 databases. Copy the backup to **C:\temp**.
5. Restart the DICENTIS services using the DICENTIS Server Console.

16.6 Updating a database to the current version

1. Stop DICENTIS services using the DICENTIS Server Console.
2. Open a command prompt in **Administrator mode**.
3. Go to: **C:\Program Files\Bosch\DICENTIS**.
4. To update the database to the current version, run **DcnmDatabaseConsole.exe**.
5. Restart the DICENTIS services using the DICENTIS Server Console.

16.7 Creating a clean database

1. Stop DICENTIS services using the DICENTIS Server Console.
2. Open a command prompt in **Administrator mode**.
3. Go to: **C:\Program Files\Bosch\DICENTIS**.
4. Run **DcnmDatabaseConsole.exe -n**.
5. Restart the DICENTIS services using the DICENTIS Server Console.

16.8 Deleting a database

Deleting a database will remove the database files. The system will not work anymore unless a new database is created or a previous database is restored. This function can be used to delete the database if you need to downgrade to a previous version.

1. Stop DICENTIS **services** using the **DICENTIS Server Console**.
2. Open a command prompt in **Administrator mode**.
3. Go to: **C:\Program Files\Bosch\DICENTIS**.
4. To delete the database, run **DcnmDatabaseConsole.exe -x**.

Note: Without a database, the DICENTIS system will not function properly. A database needs to be created or restored to make the system functional again.

16.9 Connecting DICENTIS to a (remote) SQL server

The DICENTIS system uses environment variables to access the database. The default values are used when environment variables are not present.

The environment variables used for the database name and database server are:

MMCN_DB_SERVER	The Database server PC name and server instance name. Format: MachineName\instanceName (the instance name can be omitted when the default instance is used. The machine name can be a dot ('.') when the local machine is used) Default: .\SQLDICENTIS2019
MMCN_DB_USER_ID	SQL server user-Id (SQL authentication). When absent, integrated authentication is used.
MMCN_DB_PW	SQL server password (SQL authentication). Only valid in combination with MMCN_DB_USER_ID
MMCN_DB_DATABASE	DICENTIS database name. Default: DcnmDatabase

Note: DICENTIS uses two databases: the **DcnmDatabase** stores all configuration and the **DcnmLoggingDatabase** stores the logging. Using the environment variables, you can redirected the **DcnmDatabase** to another server/database. You cannot redirect the **DcnmLoggingDatabase**. The logging database is always located on the default server (.\SQLDICENTIS2019).

Creating a new environment variable

To create a new environment variable:

1. Right click "This PC" \ Properties \ Advanced system settings \ Environment Variables \ System variable \ New
2. Enter the required variable name

3. Enter the required variable content

Creating the database on the SQL server

- The console tool DcnmDatabaseConsole.exe is used to create the database. When necessary to copy the tool, the following files have to be copied:

DcnmDatabaseConsole.exe

The DcnmDatabaseConsole tool also uses the environment variables to create the database. So, after setting the environment variables and opening the console window, the remote database is created using “DcnmDatabaseConsole -n”

Note: When using the DcnmDatabaseConsole.exe the user credentials must have the rights required to create the database.

The environment variables can be overruled by passing arguments to the DcnmDatabaseConsole.exe (For help on the command-line syntax and the available options, execute the command with the -? option):

- -s to pass the server name and the instance name
- -u to pass the user-ID for SQL-authentication (Windows authentication when omitted)
- -p to pass the user-ID’s password
- -d to pass the databasename

Remote and target

The DcnmDatabaseConsole.exe also includes command line options to do database backup and restore functions. These functions are restricted/limited when used in combination with a remote SQL-server.

Remote machine: where the DICENTIS services are running.

- A new database can be created from the remote machine.
- A database backup can be started from the remote machine

Target machine: Where the database is running.

- A database can only be restored from the target machine.

Windows Authentication example

This example shows how to use windows authentication to connect to the remote SQL server named **SQLENT1** on machine **SQLSRV**.

The database to use for the system is **MainConfHall**:

Environment variable	Value
MMCN_DB_SERVER	SQLSRV\SQLENT1
MMCN_DB_DATABASE	MainConfHall

Database creation:

Remote:

DcnmDatabaseConsole -n

On target:

DcnmDatabaseConsole -s \SQLENT1 -d MainConfHall -n

SQL authentication example

This example shows how to use SQL authentication to connect to the remote SQL server named **SQLENT2** on machine **SQLSRV**.

The user name and password to use are respectively: **DcnmUser** and **P@ssw0rd**. The database to use is **ConfHall53**:

Environment variable	Value
MMCN_DB_SERVER	\\SQLSRV\SQLENT2
MMCN_DB_DATABASE	ConfHall53
MMCN_DB_USER_ID	DcnmUser
MMCN_DB_PW	P@ssw0rd

Database creation:

Remote:

```
DcnmDatabaseConsole -s \\SQLSRV\SQLENT2 -d ConfHall53 -u DcnmUser -p P@ssw0rd -n
```

On target:

```
DcnmDatabaseConsole -s .\SQLENT2 -d ConfHall53 -u DcnmUser -p P@ssw0rd -n
```

SQL authentication example to default instance

This example shows how to use SQL authentication to connect the default SQL server on machine **SQLSRV**. The example is the same as the previous version, except that the connection is to the default SQL server instant of a defined instance.

The user name and password to use are respectively: **DcnmUser** and **P@ssw0rd**. The database to use is **ConfHall53**:

Environment variable	Value
MMCN_DB_SERVER	\\SQLSRV
MMCN_DB_DATABASE	ConfHall53
MMCN_DB_USER_ID	DcnmUser
MMCN_DB_PW	P@ssw0rd

Note: In this situation, the term Integrated Security=True is removed.

Database creation:

Remote:

```
DcnmDatabaseConsole -n
```

Note: if no parameters are set, then the environment variables are used. If parameters are set, then these will override the environment variables.

On target:

```
DcnmDatabaseConsole -s . -d ConfHall53 -u DcnmUser -p P@ssw0rd -n
```

16.10

Downgrading DICENTIS software to a previous version

Uninstalling DICENTIS software and installing a previous version will not result in a working system, because the database of the current version is not compatible with the previous version.

You need to restore a database of that previous version or delete the current database.

Delete the current database so you can install a previous version of the software. Refer to *Deleting a database*, page 136.

Uninstall the current version:

1. From the Windows **Start** icon, select **Control Panel > Programs and Features**.
2. Manually uninstall the following programs:
 - ARNI Configuration Tool.
 - Bosch DICENTIS.
 - Bosch DNS-SD Service, this un-install signals for a reboot.
 - OMNEO ARNI Firmware.
 - OMNEO Firmware Upload Tool.
 - OMNEO Docent.
3. Reboot the PC.
4. Install the previous DICENTIS software version, as described in *Installing the DICENTIS software suite*, page 27.

Restore a database backup of the previous version. Refer to *Restore a database*, page 135.

Update the database to the installed software version:

1. Stop DICENTIS services using the DICENTIS Server Console.
2. Open a command prompt in **Administrator mode**.
3. Go to: **C:\Program Files\Bosch\DICENTIS**.
4. To update the database to the current version, run **DcnmDatabaseConsole.exe**.
5. Restart the DICENTIS services using the DICENTIS Server Console.

16.11 Downgrading 4.1 or later DICENTIS software to a 4.0 or earlier version

When you downgrade from version 4.1 or later to version 4.0 or earlier, the last database you created with those versions will be used. Version 4.1 and later use a different database from 4.0 and earlier.

Uninstall the current version:

1. From the Windows **Start** icon, select **Control Panel > Programs and Features**.
2. Manually uninstall the following programs:
 - ARNI Configuration Tool.
 - Bosch DICENTIS.
 - Bosch DNS-SD Service, this un-install signals for a reboot.
 - OMNEO ARNI Firmware.
 - OMNEO Firmware Upload Tool.
 - OMNEO Docent.
3. Reboot the PC.
4. Install the previous DICENTIS software version, as described in *Installing the DICENTIS software suite*, page 27.

If the installation failed with the notification of database incompatibility, remove your database.

Note: This will remove the complete configuration.

1. Stop the **SQL server (SQLEXPRESS)** through the Services.

2. Delete the files **DcnmDatabase_log.LDF** and **DcnmDatabase.mdf** files in **C:\Program Files\Microsoft SQL Server\MSSQL12.SQLDIENTIS2014\MSSQL\DATA**.
3. Reboot the DICENTIS server.
4. Install the previous DICENTIS software version, as described in *Installing the DICENTIS software suite*, page 27.

16.12 For DICENTIS Conference System Pre-4.40

Activation tool description

- **Fulfillments** window: Shows the fulfillments activated on the system. When more than one fulfillment is activated, an **All Fulfillments** line is displayed at the top of the **Fulfillments** window. Selecting a fulfillment line displays the related licenses in the **List of licenses and quantity** pane. The fulfillment lines have the following color codes:
 - Black: The fulfillment is okay.
 - Orange: The fulfillment is not trusted and should be repaired.
 - Gray and strike-through: The fulfillment is returned and is awaiting the response to be removed.
 - Gray and strike-through: The fulfillment has expired (time limited). Return the license to clean up your system.
- **List of licenses and quantity** window: For each license, this window shows: **Qty** (number of licenses), **Order number**, **Description**, **Activated** (activation date of license), and **Expires** (expiry date of license).
- **Software Maintenance Agreement** window: Shows the Software Maintenance Agreement (SMA) end date. When the SMA end date has expired, it turns red and the additional red text **System is not operational! Additional SMA is required.** is displayed at the bottom of the window.
- **Add fulfillment**: Use this button to add a fulfillment. A fulfillment can consist of one or more licenses that add additional functionality to the system.
- **Return fulfillments**: Use this button to return fulfillments/licenses, as required. Do this when the functionality is no longer required for a system, for example, when you want to install the software on another server.



Notice!

You can upgrade your version of the Activation tool by clicking the **Update license** button (online mode) or downloading the response file on the activation site and process that response file on the Activation tool (offline mode).

16.12.1 Initial activation of the system

Activate the system for initial use as indicated below.

- Before you start, make sure you have:
 - an activation ID (this was sent by email after purchasing the software license).
 - Technician rights.
 - a PC connected to the internet.
 - a USB stick (for offline activation).

**Notice!**

To perform the following steps, your user account must have “Technician rights”. The “Admin user” of your organization can grant these rights.

At the server PC:

- Start the DICENTIS activation tool by right-clicking the **DICENTIS Server Console** in the Windows taskbar and then clicking **Activate licenses**.
- Click the **Add fulfillment** button.
- Enter all required information including the activation ID. The activation ID is on the **Overview** page of the **System Activation Website** (see *Overview, page 125*) and is included in the email you received after purchasing the software license.

For online activation

- In the **Online** tab, enter the **User name** and **Password** for the dealer site, and click **Activate licenses**.
- The **Progress** message panel will display status messages during the activation process.
- Restart the services by right-clicking the **Restart services** (see *Server console, page 31* *Server console, page 31*). Now the system is activated.

**Notice!**

If the Internet connection requires proxy configuration, you can click on “**Use this link to configure your proxy settings**” to access the proxy configuration directly. Here, click the checkbox “**Bypass proxy server for local addresses**” to allow logos and images to be displayed properly in a local network.

For offline activation

Still at the server PC:

- In the **Offline** tab, click on the **Create request** button and store the **Request file** on the USB stick.
- Leave the Activation tool open so you can easily process the **Response file** from the activation website.
 - **Note:** The **Create request** button is only accessible when there are Activation IDs in the list.
- In a computer with Internet access, visit <https://licensing.boschsecurity.com>:
- Log in with your username and password (with Technician rights).
- Select the **Manage license** tab page.
- Use the USB stick to process the **Request file** on this page.
- After processing the **Request file**, save the **Response file** to the USB stick.

Back at the server PC:

- Insert the USB stick.
- Click the **Process response** button from the **Add fulfillment** window
- Upload the **Response file**.
- Restart the services by right-clicking the **Restart services** (see *Server console, page 31*). Now the system is activated.

16.12.2**Adding additional fulfillments/licenses**

If you want to add additional fulfillments/licenses to the system, the system must have a valid SMA. This ensures for correct functioning of the latest DICENTIS features.

**Caution!**

Upgrading the DICENTIS system without having a valid SMA can cause the system to stop functioning.

16.12.3 Returning and repairing a license

Returning a license

Use the **Returning a license** function of the Activation tool to either:

- return a license.
- release a license, so that you have the possibility to install the DICENTIS software on another server instead.

You can return licenses both online and offline.

To return a license online:

1. Click the **Return fulfilments** button.
2. In the **Online** tab, enter the **User name** and **Password** for the dealer site and press the **Return fulfilments** button to return the fulfillments.

To return a license offline:

1. Click the **Return fulfilments** button.
2. In the **Offline** tab, select the fulfillments you want to return.
3. Make sure you finalize the process by pressing the **Process response message** button.

The procedure on the website is similar to activating a license.

Repairing a license

If a license becomes corrupted, the software will not work correctly. The server console will announce the issue with an on-screen warning message. The activation tool will then enable the **Repair license** button.

To repair a license: click the **Repair license** button, and then follow the instructions on screen. The procedure on the website is similar to activating a license. See *Adding additional fulfillments/licenses*, page 141.

16.13 Making a backup of a FNP license file

NOTE: This feature is no longer required with the new licensing method.

After installing the licenses on the system, the license files should be backed-up. This will prevent license(s) being lost if the hard-drive containing the licenses crashes or is formatted. The directory should be saved in a safe location, preferably on another hard-drive.

To do this:

1. Stop all services of 'Bosch DICENTIS', including the **Bosch DICENTIS License Manager** and **FlexNet Licensing Server 64'** services. Always do this before performing a backup and/or restore.
2. To make a backup of trusted storage, copy **C:\ProgramData\FlexNet** to a backup location.
3. To make a restore, copy these files to the PC that originally stored them.

**Notice!**

The folder and files are normally hidden in Windows. Change the setting of Windows Explorer to make them visible, by selecting: Organize > Folder and search options > View.

16.14**Installing the image server on a different computer**

To improve performance and/or saving space, you can install the DICENTIS image server on a different computer:

1. Open the DVD.
2. Locate the **DCNmCertificate.msi**, the **DCNmApi.msi**, the **DCNmServerTools.msi** and the **DCNmImageServer.msi**.
3. Login to the computer on which you want to install the image server.
4. Install the **DCNmCertificate.msi**.
5. Install the **DccnmApi.msi**.
6. Install the **DCNmServerTools.msi** and the **DccnmImageServer.msi**.
7. Make a note of the computer name or the IP address and port that is used by the image server.
 - The default is 31418.

For security purposes, install a server certificate on the Image server computer. If the private root certificate of the DICENTIS server computer is used to create the server certificate on the Image server PC, the client PC only needs to download one certificate for both the DICENTIS webserver (Synoptic control, Conference protocol) and the Image server (participant images, logo).

1. Open the **Certificate manager** on the Image server computer.
2. Open the Root certificate.
 - Use the <name>-private.pfx and the password of the Root certificate which is also used on the DICENTIS server Computer.
3. Enter the respective information in the **Server certificate** fields.
4. Click **Create and install** to create to install the Server certificate on the Image server computer.

**Notice!**

To create the Server certificate on the Image server computer you need the <name>-private.pfx and password of the Root certificate from the DICENTIS server computer. If you are not able to retrieve them, you need to create and install a new Root and Server certificate on the DICENTIS server computer.

To change the location of the image service:

1. Start the Meeting application.
2. Navigate to **Configure > Rooms**.
3. Enter the url of the new image server in **Image Server url**.
 - Example:** If the computer name is CITYCOUNCILIMAGESERVER and the port is 31418, enter the Uri as: **https://CITYCOUNCILIMAGESERVER:31418/**.
4. Click **Test image server connection** to ensure that the new DICENTIS image server is valid.
5. Click **Apply** to save the new image server url.

16.15 Recovering devices from fail-safe mode

Although the utmost has been done to safeguard the availability of the system, a situation can occur where a DICENTIS device enters a fail-safe mode which requires a reload of the firmware. To reload the firmware:

1. Power up the device.
2. Start the **Firmware Upload Tool**. After some time the Firmware Upload Tool shows the **devices in failsafe mode** window with the id of the defective device displayed.
3. Wait until the device appears in its specific tab of the Firmware Upload Tool (DCNM-APS / DCM-APS2, DCM-PS2 or DCM-MMD2 / DICENTIS Discussion device).
4. Close the **Firmware Upload Tool**. The device is now fully operational again.

16.16 Replacing a defective device

A defective device can be easily replaced, without reconfiguring. To do so:

1. Replace the defective device.
2. Upgrade the replacement device with the correct firmware, if necessary.
3. Select: **Configure > Seats and Devices > Seat Assignment**.
4. Unassign the defective device from the seat by using the **Unassign Devices from Seat** button. Record the number/name of the defective device (see sticker on base of device).
Tip: Use your mobile phone to take a picture of the sticker.
5. When **Automatic seat assignment** is enabled, the replacement device must first be unassigned from its current seat before it can be assigned to the correct seat. Unassign the replacement device from the seat by using the **Unassign Devices from Seat** button.
6. Assign the replacement device to the correct seat using the **Assign Device to Seat** button.
7. Remove the empty seat with the **Delete empty seats** button.

16.17 Uploading and accessing files

Background information

During a meeting, participants can open and view files (i.e.: documents, pictures, and presentations) by clicking a blue **More info** hyperlink on the multimedia devices (DCNM-MMD2 only). The **More info** hyperlink is displayed for:

- each meeting,
- each agenda item, and
- each voting round.

For participants to be able to use this hyperlink:

- the documents have to be uploaded to the customer's Content Management System (CMS), and
- a URL (link) has to be entered in the Prepare pages for:
 - each meeting (see *Meeting details, page 53*),
 - each agenda item (see *Topic details, page 56*), and
 - each voting round (see *Voting round details, page 57*).

Document folders can be created as required; for example, separate document folders can be created for "Meeting", "Agenda", and "Voting" for storing relevant documents, or single "Meeting" folders can be created for storing all documents.

The advantage of using separate folders is that only the relevant documents will be displayed when one of the **More info** hyperlinks is pressed, i.e. only documents relevant to voting will be displayed when the **More info** hyperlink for voting is pressed. The disadvantage, however, is that individual hyperlinks have to be entered in the prepare pages for each folder.

For demo purposes a Meeting documents webserver can be installed manually: **Tools** > **DCNmMeetingDocuments.msi**. This is a simple website to enable document browsing. The meeting documents directory is installed on the drive that has the most space available on the server.

Note: This is not necessarily the C drive.

Technician tasks

Set up the **meetingdocuments** directory:

1. Use the Internet Information Services (IIS) Manager and Explore (inetmgr) to determine on which drive the **meetingdocuments** directory is installed.
2. Share the **meetingdocuments** directory, so that the secretary can access it.
3. Create a shortcut to the **meetingdocuments** directory on the secretary's computer.

Create one or more folders on the DcnmMeetingDocuments website:

1. In the **meetingdocuments** directory, create a folder for each meeting; for example, **meeting_1**, **meeting_2**, **meeting_3**. These folders are used to store the documents that are displayed when the **More info** hyperlink is pressed.
2. Optional: In each of the meeting folders, create folders for each agenda item and each voting round; for example, **agenda_1**, **agenda_2**, and **voting round_1**, **voting round_2**.

Secretary or clerk tasks

Upload files to the **meetingdocuments** directory:

1. Click the shortcut to the **meetingdocuments** directory, or use Windows Explorer to browse to **(Drive):\inetpub\wwwroot\DcnmMeetingDocuments**.
2. Make sure the technician has created the appropriate folders, as described in **Technician tasks**. See previous section.
3. Upload files (i.e.: documents, pictures, and presentations) to the appropriate folder(s), as required.

Enter URLs (links) for the meeting and agenda items:

- Use the following format to create URLs (links) in the meeting and agenda items:
http://<IP-address of the DICENTIS server PC>:31415/Default.aspx
- If each meeting has its own directory with documents, the URLs (links) should have the following format:
http://<IP-address of the DICENTIS server PC>:31415/Default.aspx?meeting=<name of the directory used in this meeting>
- If each agenda has its own directory with documents, the URLs (links) should have the following format:
http://<IP-address of the DICENTIS server PC>:31415/Default.aspx?meeting=<name of the directory used in this meeting>&agenda=<name of the directory which has the documents used for this agenda item>

Refer to:

- *Meeting details, page 53*
- *Topic details, page 56*
- *Voting round details, page 57*

Check URLs (links)

1. Activate each meeting, and check that URLs (links) to the meeting documents are displayed when the **More info** hyperlink is pressed.
2. Optional: Also do this for each agenda item and each voting round of a meeting.

16.18 Configuring the date and time format of the DICENTIS Multimedia device

The DICENTIS Multimedia devices (DCNM-MMD and DCNM-MMD2) are using the following date and time settings from the server PC:

- Time-zone
- Daylight saving time settings
- Time format (Short time)
- Date format (Short date)

To make this work properly you need to execute the following steps:

1. Configure the date and time format on the server PC
 - Open **Control Panel**.
 - Select **Change date, time, or number formats**.
 - On the **Formats** tab-page (of Region) configure the **Short date** and **Short time**. You can also make your own date and time format if you like.
Note: if you make it too long it will not fit the device.
 - Select **Apply**.
2. Configure the server that the settings are part of the administrative settings.
 - Open the tab page **Administrative** (of Region).
 - Select the button **Copy settings...**
 - Check the box.
 - Welcome screen and systems accounts.
 - Select **OK**.
3. Wait a minute and see that the format on the DCNM-MMD is updated.

16.19 Using a fixed IP address for the DICENTIS server in a DICENTIS system with ARNI support

In order to use a computer in a DICENTIS system to which you want to assign a fixed IP address, you make the following settings:

1. Go to **Control Panel > Network and Internet > View network status and tasks > Change adapter settings**.
2. Select "Internet Protocol Version 4".
3. Select the **Properties** button.
4. **Use the following IP address:** should contain the IP address of the server or the computer, the Subnet mask and the Default Gateway.
Use the following DNS server addresses: should contain the IP address of the ARNI.
5. Click the **Advanced** button.
6. The Advanced TCP/IP settings DNS page should contain the following:
 - "Append primary and connection specific DNS suffixes" is checked
 - "Append parent suffixes of the primary DNS suffix" is checked
 - "DNS suffix for this connection: " parent.bosch.omneo
 - "Register this connection's addresses in DNS" is checked

- “Use this connection’s DNS suffix in DNS registration” is checked

Note: Make sure these settings match the definitions made in your network.

1. Do a quick test to verify the settings are correct by running the screen command: C :

```
\Program Files\Bosch\DNS-SD>BoschDNSSDClient.exe -b _ocasec
```

If you see a list of DICENTIS registered in the domain “parent.bosch.omneo” it is OK. The Bosch-ARNI is registered twice, once in the “local” domain and a second time in the “parent.bosch.omneo” domain, this is normal. If you only see the Bosch-ARNI registered in the “local” domain, the DNS settings are wrong.

16.20 Selecting a network interface to work with DICENTIS

Using the environment variable, DCNM_PREFERRED_NIC, the interface name, device name (it is called description if you use the ipconfig command) can be set that you want to be used by DICENTIS.

1. Use the Windows Network Connections menu to retrieve the Name or Device name of the interface.

2. Create a new environment variable via:

```
"This PC" \ Properties \ Advanced system settings \ Environment  
Variables \ System variables \ New
```

with variable name: DCNM_PREFERRED_NIC.

Note: The NIC name is case sensitive.

Note: If the preferred NIC does not receive an IP-address (e.g. the cable is not connected, or the name is incorrect), then the services will not start.

Note: If no environment variable was set and there are several network interfaces, the network interface that was found first will be used.

16.21 Powering down the server via the power button

The DICENTIS services run on the server computer. Because these are services, it is not necessary to start them manually or even log in to this computer. Just powering on the computer is enough to get the system working. The power button on the computer can be configured to power down the computer so you do not need to log in to the computer to power it down.

Note: It is not necessary to power down the computer, but you can.

To configure the power button to power down the computer:

1. Go to **Control Panel > Hardware > Power Options** to change the function of the power button.
2. Configure “Shut down” for the option **When I press the power button**.

16.22 Camera and presentation streams

The camera stream and presentation stream are distributed by the DICENTIS VideoSwitcher service to the DICENTIS devices.

You can use these streams in your own display or recording application:

- Camera stream: `Rtsp://<DICENTIS server>:9554/stream2`
- Presentation stream: `Rtsp://<DICENTIS server>:9554/stream1`

For the camera stream, the camera control needs to be enabled.

For the presentation stream, the presentation stream needs to be enabled.

16.23 Making a backup and restoring your Synoptic configuration

The configuration of the Synoptic layout is not in the database, but it is stored in a separate file in a different location.

To make a backup of the Synoptic configuration:

Make a backup of this directory: `D:\Inetpub\wwwroot\DcnmSynopticControl\Data` (the data will be stored on your largest drive; that is D in this example) for a backup of the layout.

To make a backup of the background image, copy: D:

`\Inetpub\wwwroot\DcnmSynopticControl\Images`

If you keep this information together with the database backup you created (see paragraph 13.6),

you can restore your configuration by:

1. Restoring the database (see paragraph 13.7 and 13.8)
2. Restoring the saved Synoptic configuration and background image by pasting them in the correct location

16.24 Configuring Dante™ compatible devices

The DICENTIS Conference System supports integration with third party Dante™ compatible devices (like for example, a laptop). Configuring which Dante™ inputs and outputs are routed to the Dante™ inputs and outputs of the DICENTIS Conference System is done via Audinate's Dante Controller which can be downloaded from the Audinate website.

Note: The Dante Virtual Device is running on the DICENTIS Conference System server for the Dante™ functionality. Only one Dante™ device can be active on a computer, therefore it is not possible to install any other Dante™ device on the DICENTIS Conference System server.

Note: The Dante Controller can be run from any computer in the network. Its serves to route Dante™ inputs and outputs between Dante™ compatible devices.

1. Open the Dante Controller **Network view**.
2. The new Dante™ devices from the APS are shown on the screen:
 - Dante Receivers:
DICENTIS <hostname server>
 - Dante In 1
 - Dante In 2
 - Dante Transmitters:
DICENTIS <hostname server>
 - Dante Out 1
 - Dante Out 2
 - All other devices that are visible on the network are shown as well.

Next, multicast streams need to be created from the transmitters, as the DICENTIS Conference System utilizes these:

1. Press **Ctrl-D** to open the **Device info** view.
2. Select the device you want to configure to work with DICENTIS.
3. Go to the **Transmit** tab.
4. Press **Ctrl-M** to create a multicast flow.
Make sure to select only 1 channel per multicast flow.

5. When the multicast flows have been created, switch back to the Dante Controller network view to create the connections you want. All successful connections are shown by a check mark.
For further details on configuring Dante™, refer to the “Dante Controller User Guide”.

16.25 Setting a PIN code for a Dante™ device

To increase security and prevent access from unauthorized parties, a technician should set a 4-digit PIN code to lock each Dante™ device in the network.

To set a PIN code for a Dante™ device:

1. Open the Dante Controller application
 2. Select the *Device Info* tab
 3. In the *Device Lock* column, left click the row of the device you wish to lock
 4. Enter a 4-digit code in the *PIN* field, and confirm the code in the *Confirm PIN* field
 5. Click the *Lock* button
- ⇒ The PIN code is now set for the Dante™ device.

16.26 Adding a third-party application to a device

The APK (Android application package) upload tool is used to add a third-party Android application to a multimedia device. Before you can add a third-party Android application, you must verify if the application is compatible with the multimedia device.



Caution!

All installed third-party applications (APKs) will be deleted when firmware is uploaded to a multimedia device.



Notice!

The APK upload tool cannot run at the same time as the OMNEO Firmware Upgrade Tool.

Add a third-party Android application to a multimedia device as follows:

1. Place the APK files on the server PC.
2. Click the **Browse** button.
3. Browse to the location of the APKs.
4. Select the multimedia device which needs the APK.
5. Select the APK.
6. Click **Upload**.



Notice!

If the new APK is not shown on the home screen of the multimedia device, try to click the home button several times, or reboot the multimedia device.

16.27 Adding additional keyboards to a device

If required, additional non-European keyboards, e.g. a Chinese or Korean keyboard, can be added to a DICENTIS device.

To have an Android keyboard in a different language, you first have to upload the APK for that keyboard and then follow the setup procedure below. For information on uploading APKs, refer to *Adding a third-party application to a device*, page 149.

Two examples of APKs are:

- `com.google.android.inputmethod.korean-0.91.apk`, korean language, 877 KB
- `com.google.android.inputmethod.pinyin-3.2.1.65352638.apk`, chinese language, 12.103 KB

Setup procedure

On the DICENTIS device:

1. Press the home icon, and then press **WWW** to open the Internet browser.
2. Press the address bar in the browser to display the keyboard.
3. Press the 'slider icon' in the bottom right corner of the keyboard.
4. Press **input languages**.
5. Uncheck **Use system language**.
6. Select a minimum of 2 languages from the list.
7. Go to the browser, and press the address bar to display the keyboard.
8. Press the 'keyboard icon' in the 'android bottom bar' next to the Bosch logo.
9. Press **Set up input methods**.
10. Check the other keyboards.
11. Go to the browser, and press the address bar to display the keyboard.
12. Press the 'keyboard icon' in the 'android bottom bar' next to the Bosch logo.
13. Select the keyboard you want to use.



Notice!

Additional keyboards have to be individually configured for each DCNM-MMD2 device.



Notice!

Additional keyboards will have to be reconfigured after a firmware upgrade.

16.28 Keeping third-party android apps on top on the multimedia device when changing agenda items

When a third-party app is used as UI for the multimedia device, the multimedia device navigates to the DiscussApp (active part of the discussion) when a new agenda item is opened.

The `com.bosch.mmd.ui.action.DISCUSS` intent is sent when an agenda item is opened. The third-party app can also receive this intent. Read more on how to make that happen at <https://developer.android.com/guide/components/intents-filters>.

The multimedia device will show a pop-up the first time this event is sent:

1. Tap the checkbox **Use by default for this action**.
 2. Tap the desired app.
- ⇒ The selected app will now be used as default.

You can find some information from the AndroidManifest.xml below:

```
<activity
android:name=".DiscussAppActivity"
android:label="@string/app_name"
android:launchMode="singleTask" >
<intent-filter>
<action android:name="android.intent.action.MAIN" />

<category android:name="android.intent.category.LAUNCHER" />

<action android:name="com.bosch.mmd.ui.action.DISCUSS" />
<action android:name="com.bosch.mmd.ui.action.SHOW_PRESENTATION" />

<category android:name="android.intent.category.DEFAULT" />
</intent-filter>
</activity>
```

16.29 Creating certificates using the command line tool

Next to the UI-tool, you can also create, install and uninstall certificates using a command line tool: `Bosch.TestUtils.CertificateGenerator.exe`.

The tool is installed by default in `C:\Program Files\Bosch\DICENTIS`. It can be run via the command prompt with Administrator rights.

You can use `/help` to get the commands and usage:

- **Create the root certificate:** `CreateRootCertificate -RootCertificateName <name> -RootCertificatePassword <password>`.
- **Install the root certificate on the Client:** `InstallRootCertificate -RootCertificateCrtFilePath <file path>`.
- **Create the server certificate:** `CreateServerCertificate -RootCertificatePfxFile <file path> -RootCertificatePassword <password> -ServerCertificateName <name> -ServerCertificatePassword <password> -IPAddresses <IP Addresses comma separated> -DnsNames <DNS Names comma separated>`.
- **Install the server certificate on the Server:** `InstallServerCertificate -ServerCertificatePfxFile <file path> -ServerCertificatePassword <password>`.
- **Uninstall the root or server certificate:** `UnInstallCertificate -CertificateName <name>`.

Example:

```
Bosch.TestUtils.CertificateGenerator.exe CreateRootCertificate -
RootCertificateName DICENTIS_ROOT_CA -RootCertificatePassword DICENTIS
```

This command will create the following two files:

- C:\Program Files\Bosch\DICENTIS\ DICENTIS_ROOT_CA-private.pfx
- C:\Program Files\Bosch\DICENTIS\ DICENTIS_ROOT_CA.crt

The PFX file, together with the root certificate password, is required to create the Server certificate. The CRT file is required for the clients to access the website.

16.30 Remove unused images

When the participants are removed their images are deleted. However, if only the database is removed, the participant images remain. They can be removed by the following actions:

1. Open a command prompt in **Administrator mode**.
2. Go to :\\inetpub\wwwroot\DcnmImageServer\bin, which is normally located on the largest drive.
3. Run CleanupUnusedImages.exe to remove the participant images of persons who are no longer present in the database.

Note: You can automate deleting unused images by running CleanupUnusedImages.exe /q in quiet mode.

16.31 ONVIF Camera discovery

In the 3.60 software version, the default time to live of the ONVIF camera discovery increases from 1 to 3. This allows the discovery of the ONVIF camera when it is connected to other switches than the switch the server is connected to.

Add an environment variable to the system to change the time to live or the hop count. Name the variable and set the desired time to live:

1. Create a new environment variable via:
File explorer \ "This PC" \ Properties \ Advanced system settings \ Environment Variables \ System variables \ New
with variable name: DCNM_ONVIF_DISCOVERY_TTL.
2. Restart the DICENTIS Server.

Note: If you want the server to only discover the camera connected to the same switch you might want to decrease the time to live to 1.

16.32 Secure login in the .net API for API applications (including Synoptic)

In the 4.40 software version, the user synoptic used so that the DICENTIS Webserver could connect to the services has been removed.

By using a jsonc file with the user configurations, it will also allow other API applications to use the same mechanism, and allow them access to the .net API without having to create a system user in the DICENTIS database.

The DICENTIS Webserver still requires a user with username and password to use the API to connect to the services. The username and password are now configured and stored on the computer running the services.

The configuration is stored in C:

\\ProgramData\Bosch\DICENTIS\API\Conference_Protocol_user.jsonc

This jsonc file contains:

- The username.
- The password (generated upon the installation of the software).

-
- The user rights.

**Notice!**

For security purposes, limit the user rights to only the required rights.

16.33**Renewing the registration of the tablets**

If the SSL certificate of the DcnmSynopticControl site changes, due, for example, to an update of the IP-address or the hostname, the existing tablet registrations become invalid and need to be renewed. The registrations can be renewed by registering the tablets again. Before registering the tablets, the following entry must be added to the file %programdata%\bosch\DICENTIS\ParticipantApplication\ParticipantApplicationSettings.json:

```
"Web Api": {  
  "CertificateFriendlyName": "friendly name"  
},
```

The friendly name of the certificate can be found on the Internet Information Services at the bindings of the DcnmSynopticControl site.

17 Troubleshooting

For troubleshooting, also refer to the DICENTIS Hardware Installation manual, section “Installation Test”.

Refer to the product related information on: www.boschsecurity.com.

17.1 Devices LED behavior

Multiple DICENTIS devices use different LED behavior to indicate their status:

DCNM-D / DCMN-DVT / DCMN-DSL / DCMN-DE / DCMN-FBD2	
LED of the microphone and its button: Alternates between green and red DCNM-DSL / DCMN-DE: Please upgrade appears in the display	Device is out of the box
DCNM-Dx: Microphone button LED steady green and microphone LED off -> Microphone button LED off and microphone LED blinks red DCNM-FBD2: Microphone button LED and microphone LED steady green	Device is booting
Microphone LED steady green DCNM-DE: No communication with DICENTIS server appears in the display	Device is booted, not connected to services, and has a Link local address
Microphone LED is steady red DCNM-DE: No communication with DICENTIS server appears in the display	Device is booted, not connected to services, and has a DHCP address
Microphone LED and microphone button LED off If the system is set to discussion mode Open (automatic): Microphone LED off and microphone button LED white DCNM-DE: The discuss screen appears in the display	Device is connected to services

DCNM-MMD2	
LED of the microphone and of its button: alternates between green and red Please upgrade appears in the display	Device is out of the box

Microphone LED blinks red / Rear LED blinks red	Device is booting
Microphone LED is steady green / Rear LED is steady red Cannot communicate with DICENTIS server appears in the display	Device is booted, not connected to services, and has a Link local address
Microphone LED steady red / Rear LED steady red Cannot communicate with DICENTIS server appears in the display	Device is booted, not connected to services, and has a DHCP address
Rear LED off The DICENTIS logo appears in the display	Device is not assigned to a seat
Microphone and button LEDs off The discuss screen appears in the display	Device is connected to services

DCNM-FSL	
Alternate blinking of the upper and lower buttons Please upgrade appears in the display	Device is out of the box
Both of the volume LEDs and both of the language LEDs illuminated constantly	Device is booted, but not connected to services, and has a DHCP address
Display off With no headphone connected, both of the volume LEDs and both of the language LEDs off With a headphone connected and languages configured, both of the volume LEDs and both of the language LEDs on	Device is connected to services

DCNM-IDESK	
LED of the microphone and of its button: alternates between green and red Please upgrade appears in the display	Device is out of the box

Microphone LED steady red / Rear LED steady red Cannot communicate with DICENTIS server appears in the display	Device is booted, but not connected to services
The DICENTIS logo appears in the display	Device is not assigned to a seat

**Notice!**

Click the More button on the right side of device to retrieve additional information, such as the Link local address or the DHCP address.

17.2**Network Docent**

Network Docent is developed to help AV operators in their daily job. The software scans and visualizes the network environment, giving insight into all devices and cable-connections of a network-based AV system. Network Docent is able to identify and provide guidance on solving common and simple network errors that cause disruption or improper operation of the AV system. As a result, Network Docent will reduce time and effort, when installing or operating a network-based AV system.

As of version 3.2, the Network Docent software is installed as part of the DICENTIS software package.

**Notice!**

Do not abort the DICENTIS software installation when installing Network Docent

Please refer to the Network Docent manual for more information on how to use the tool. The Network Docent software and manual can also be downloaded from:
<https://licensing.boschsecurity.com/omneo/>

17.3**Using DeviceBrowser to view connected devices**

DeviceBrowser.exe is a command prompt tool which allows a technician to get an overview of which devices are connected. It shows the type, quantity and which VLAN devices are connected to.

To start the tool:

1. Click the Windows Start button.
2. Type **command** in the search field and press Enter.
The Command Prompt will open.
3. Type **cd** and press Enter.
4. Type **cd "Program Files\Bosch\DICENTIS"** and press Enter.

5. Type **DeviceBrowser.exe** and press Enter.
The tool will automatically scan the network for DICENTIS devices.
The scan can be stopped by pressing CTRL + C.

17.4 Dumping logging information to a text file for technical support

The DICENTIS logging file can be very helpful to analyze a problem. The logging information can be exported to a text file and emailed to support.

When emailing the logging file to support, please include all relevant information related to the circumstances when the issue occurred.

To create the logging file:

1. Open a command prompt.
2. Go to: **C:\Program Files\Bosch\DICENTIS**.
3. Run `logdump <filename>`.

For a continuous logdump use `logdump -c <filename>`. The logging will stop when a key is pressed.

17.5 Adding and removing languages without interrupting the meeting

You can add and remove interpretation languages during a meeting without interruption.

When you remove a language:

- Participant devices with the removed language selected will switch to floor
- Interpreter desks with the removed language selected as the A-output will go to the blocked screen (DICENTIS logo)
- The microphone of the interpreter desk interpreting the removed language will be turned off

17.6 Known issues

Refer to the following sections for known issues and their solutions:

- *Releasing Dual License, page 157*
- *Network, page 158*
- *Software and hardware installation, page 158*
- *Meeting application and DICENTIS device, page 158*
- *Camera control, page 159*
- *MMD does not show logo and participant image, page 160*

17.6.1 Releasing Dual License

Issue:

If a device with a dual license is broken, the license will not be automatically returned.

Solution:

Restart the services on the server console, the licenses will be recalculated and the dual license will be released.

17.6.2

Network

Issue:

Delay of audio in a multi-subnet DICENTIS Conference System using Cisco c3560x with firmware 15.0.1 SE3 c3560e-universalk9-mz.150-1.SE3.bin

Solution:

Use the tested and supported firmware versions:

- 12.2.55 SE5 (c3560e-universalk9-mz.122-55.SE5.bin)
- 15.2.2E (c3560e-universalk9-mz.152-2.E.bin)

Issue:

Client PC does not connect to DICENTIS server when it is not in the same subnet.

Solution:

Define and configure the system in such a way that all Client PC's are in the same subnet as the DICENTIS server.

17.6.3

Software and hardware installation

Issue:

Failsafe devices are not automatically restored by the FWUT if they are not in the same subnet as the FWUT, e.g. a multi-subnet network with an ARNI.

Solution:

Disconnect all devices that are in failsafe mode and connect them to a system with one subnet and without an ARNI. The failsafe mechanism is based on multicast DNS, which causes this technical constraint. Failsafe works with multicast DNS; this is a technical constraint.

Issue:

Upgrading DICENTIS devices (DCNM-MMD) that have factory firmware prior to 1.2 does not work in a system with an ARNI, because the Firmware Upload Tool does not list the DCNM-MMDs.

Solution:

Upgrade the DICENTIS devices with the ARNI disconnected.

Note: Limit the system size to a maximum of 100 DCNM-MMDs while upgrading.

Issue:

The system stops working after a new user is created at the PC running the DICENTIS software services.

Solution:

Reboot the server PC.

17.6.4

Meeting application and DICENTIS device

Issue:

When using the home button in the browser and the **Back to Active** button (large green button), to return to the active meeting after browsing the internet, there is a delay of about 4 seconds.

Solution:

This is standard Android behavior.

When the back button in the browser is used, and then the **Back to Active** button, there is no delay.

Issue:

The Meeting application shows disabled buttons or missing buttons. The DICENTIS devices show the disconnected screen.

Solution:

Disable the sleep mode of the server PC, and then reboot the server.

Issue:

The Meeting application and the DICENTIS devices show a different time.

Solution:

Enable daylight saving on the PC running the Meeting application.

Issue:

Cannot access screens upon moving the screen splitters to the edge of the window.

Solution:

Delete the file `user.config` in C:

```
\Users\admin\AppData\Local\Bosch\Bosch.Dcnm.UserInterfaces_StrongName_4bkwh  
n14ajzhneng3j1ucxubjyvms2k\<software version>.0
```

17.6.5

The Interpreter desk displays the DICENTIS logo

Issue:

The device is not assigned to an Interpreter desk and booth

Solution:

Assign the device to an Interpreter desk and booth using the Interpreter desk or the Meeting application

Issue:

The Interpreter desk has no A-output language configured

Solution:

Configure an A-output language using the Interpreter desk or the Meeting application

Issue:

The A-language of the Interpreter desk is assigned to a source other than DICENTIS

Solution:

Set the source to DICENTIS in the **Rooms > Language** selection or in the prepared meeting

Issue:

The device has incorrect firmware

Solution:

Upload the firmware using the firmware upload tool that is installed on the DICENTIS server

17.6.6

Camera control

Issue:

Camera pre-positions cannot be set at the seats.

Solution:

1. Close the Meeting application.
2. Remove the file: **C:**
`\Users\«servername»\AppData\Local\Bosch\Bosch.Mmcn.UserInterfaces_...`
3. Restart the Meeting application.

17.6.7 MMD does not show logo and participant image

Issue:

After upgrading to DICENTIS Conference system 3.60, TLS1.0 is disabled for security reasons, and TLS1.2 is enabled. Since the Multimedia device does not support TLS1.2, it does not show logo and participant images anymore.

Solution:

Enable TLS1.0 on the server:

1. Open a command prompt in **Administrator mode**.
2. Run `\Tools\TLS_MMD\EnableTLS1.0.bat` from the DICENTIS ISO file.
3. Powercycle the server.

Note: This directory also contains a file to disable TLS1.0.

17.7 Customer service

If a fault cannot be resolved, please contact your supplier or system integrator, or go directly to your Bosch representative.



Support

Access our **support services** at <https://www.boschsecurity.com/xc/en/support/>.

Bosch Security and Safety Systems offers support in these areas:

- [Apps & Tools](#)
- [Building Information Modeling](#)
- [Commissioning](#)
- [Warranty](#)
- [Troubleshooting](#)
- [Repair & Exchange](#)
- [Product Security](#)



Bosch Building Technologies Academy

Visit the Bosch Building Technologies Academy website and have access to **training courses**, **video tutorials** and **documents**: <https://www.boschsecurity.com/xc/en/support/training/>

18 Support and Academy



Support

Access our **support services** at www.boschsecurity.com/xc/en/support/.

Bosch Security and Safety Systems offers support in these areas:

- [Apps & Tools](#)
- [Building Information Modeling](#)
- [Warranty](#)
- [Troubleshooting](#)
- [Repair & Exchange](#)
- [Product Security](#)



Bosch Building Technologies Academy

Visit the Bosch Building Technologies Academy website and have access to **training courses**, **video tutorials** and **documents**: www.boschsecurity.com/xc/en/support/training/

Bosch Security Systems B.V.

Torenallee 49

5617 BA Eindhoven

Netherlands

www.boschsecurity.com

© Bosch Security Systems B.V., 2025

Building solutions for a better life

202501241557