

DICENTIS

Conference System

Table of contents

1	Safety	5
2	About this manual	7
2.1	Intended audience	7
2.2	Alerts and notice signs	7
2.3	Copyright and disclaimer	7
2.4	Document history	7
3	System installation overview	9
3.1	Typical system setup	10
3.2	System extension	13
4	System installation design and planning	16
4.1	System capabilities	16
4.2	Hardware requirements	18
4.3	Power supply capacity calculation plan	21
4.3.1	Calculation using DCNM-APS2 or DCNM-PS2	21
4.3.2	Calculation using PoE switches	25
4.4	Redundancy options	27
4.4.1	Redundant cabling for DCNM-APS2/DCNM-PS2 units	28
4.4.2	Redundant server PC	30
5	Installation material and tools	31
5.1	DCNM-CBCPLR Cable couplers	31
5.1.1	Using a cable coupler to extend a cable	32
5.1.2	Using a cable coupler as a break-out box	32
5.1.3	Using a cable coupler as an interface between different types of cable	33
5.1.4	Using a cable coupler to insert power locally	34
5.1.5	Using a cable coupler to switch the system on	35
5.2	DICENTIS System cable assemblies	38
5.3	DCNM-CBCON Connectors for DICENTIS cable	39
5.4	DCNM-CBTK System Network Cable Toolkit	40
5.5	DCNM-CB250 System installation cable	41
5.6	DCNM-IDESKINT On-air & teleph. DCNM-IDESK	42
6	Mechanical installation of Central Equipment	46
6.1	Audio processor and powering switch and Powering switch	46
6.2	System server	50
6.3	Dante gateway	51
7	Mechanical installation of Contribution Devices	55
7.1	Connecting DICENTIS devices	55
7.2	DICENTIS tabletop devices	57
7.3	DICENTIS flush-mounted devices	60
7.3.1	DCNM-FBD2 Flush base device	65
7.3.2	DCNM-FMCP Flush microphone connection panel	68
7.3.3	DCNM-FMICB Flush microphone button panel	69
7.3.4	DCNM-FPRIOB Flush priority button panel	70
7.3.5	DCNM-FLSP Flush loudspeaker panel	70
7.3.6	DCNM-FVP Flush voting panel	73
7.3.7	DCNM-FSLP Flush language selection panel	73
7.3.8	DCNM-FAI Flush audio interface	76
7.3.9	DCNM-FHH / DCNM-FHHC Flush hand held microphones	82
7.3.10	DCNM-FIDP Flush identification panel	83

7.3.11	DCNM-FICH Flush ID card holder	84
7.3.12	Flush setups	85
7.3.13	DCNM-FSL Flush language selector	87
7.4	DCNM-IDESK / DCNM-IDESKVID Interpreter desk	91
7.5	DICENTIS Microphones	94
7.6	DCNM-MMDSP Anti-reflection foil	96
7.7	DICENTIS Card holders	97
7.7.1	DCNM-NCH Name Card Holder	97
7.7.2	DCNM-DICH ID card holder for DCNM-D	97
8	Installation Test	99

1 Safety

Prior to installing or operating products, always read the Important Safety Instructions which are available as a separate multilingual document: Important Safety Instructions (Safety_ML). These instructions are supplied together with all equipment that can be connected to the mains supply.

Safety precautions

Some of the DICENTIS Conference System products are designed to be connected to the public mains network.

To avoid any risk of electric shock, all interventions must be carried out with disconnected mains supply.

Interventions with the equipment switched on are authorized only when it is impossible to switch the equipment off. The operation must only be performed by qualified personnel.

Old electrical and electronic equipment

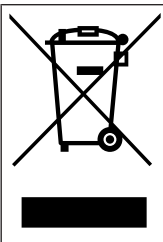

This product and/or battery must be disposed of separately from household waste. Dispose such equipment according to local laws and regulations, to allow their reuse and/or recycling. This will help in conserving resources, and in protecting human health and the environment.

Class A equipment (commercial broadcasting equipment)

This equipment is for professional (Class A) electromagnetic compatibility equipment. Seller or user should pay attention to this point. It is intended for use outside the home.



Warning!

Changes or modifications made to this equipment, not expressly approved by Bosch Security Systems B.V. may void the user's authority to operate the equipment.

FCC Statement - Wired Class A digital device (unintentional radiator)

This equipment has been tested and found to comply with the limits for a Class A digital device, pursuant to part 15 of the FCC Rules. These limits are designed to provide reasonable protection against harmful interference when the equipment is operated in a commercial environment. This equipment generates, uses and can radiate radio frequency energy and, if not installed and used in accordance with the instruction manual, may cause harmful interference to radio communications. Operation of this equipment in a residential area is likely to cause harmful interference in which case the user will be required to correct the interference at his own expense.

Note: The FCC Wired Class A statement applies to:

- OMN-DANTEGTW
- DCNM-MMD2
- DCNM-D
- DCNM-FBD2
- DCNM-FMCP
- DCNM-FMICB
- DCNM-FPRIOB
- DCNM-FLSP
- DCNM-MICSL5
- DCNM-MICSL6

- DCNM-FVP
- DCNM-FAI
- DCNM-FSLP
- DCNM-FIDP
- DCNM-FHH
- DCNM-FHHC

FCC and IC Wireless Statement

This device complies with Part 15 of the FCC Rules and with Industry Canada license exempt RSS standard(s). Operation is subject to the following two conditions:

- (1) this device may not cause harmful interference, and
- (2) this device must accept any interference received, including interference that may cause undesired operation.

Le présent appareil est conforme aux CNR d'Industrie Canada applicables aux appareils radio exempts de licence. L'exploitation est autorisée aux deux conditions suivantes:

- (1) l'appareil ne doit pas produire de brouillage, et
- (2) l'utilisateur de l'appareil doit accepter tout brouillage radioélectrique subi, même si le brouillage est susceptible d'en compromettre le fonctionnement.

Note: The FCC and IC Wireless statement applies to:

- DCNM-MMD2
- DCNM-DVT
- DCNM-DSL
- DCNM-DE
- DCNM-IDESK
- DCNM-IDESKVID
- DCNM-FIDP

2 About this manual

The purpose of this manual is to provide information required for installing the DICENTIS Conference System.

This installation manual is available as a digital document in the Adobe portable document format (PDF).

For more information, refer to the product related information on www.boschsecurity.com

2.1 Intended audience

This hardware installation manual is intended for installers of a DICENTIS Conference System.

2.2 Alerts and notice signs

Four types of signs can be used in this manual. The type is closely related to the effect that may be caused if it is not observed. These signs - from least severe effect to most severe effect - are:



Notice!

Containing additional information. Usually, not observing a ‘notice’ does not result in damage to the equipment or personal injuries.



Caution!

The equipment or the property can be damaged, or persons can be lightly injured if the alert is not observed.



Warning!

The equipment or the property can be seriously damaged, or persons can be severely injured if the alert is not observed.



Danger!

Not observing the alert can lead to severe injuries or death.

2.3 Copyright and disclaimer

All rights reserved. No part of this document may be reproduced or transmitted in any form by any means, electronic, mechanical, photocopying, recording, or otherwise, without the prior written permission of the publisher. For information on getting permission for reprints and excerpts, contact Bosch Security Systems B.V.

The content and illustrations are subject to change without prior notice.

2.4 Document history

Release date	Documentation version	Reason
2023-01	V4.2	Update to DCNM-CB250-I and OMN-DANTEGTW. Added: – DCNM-SERVER3 – DCNM-FBD2

Release date	Documentation version	Reason
		<ul style="list-style-type: none">- DCNN-CB250-CPR- INT-TXO.
2023-04	V4.4	Added: <ul style="list-style-type: none">- DCNM-FVP- DCNM-FSLP- DCNM-FAI- DCNM-FHH- DCNM-FHHC- DCNM-FIDP- DCNM-FICH.
2023-08	V5.1	Update to the subchapter Flush setups.
2024-01	V6.1	Update to the Safety chapter, DCNM-CBCPLR, and DCNM-FAI.

3 System installation overview

It is advisable to participate in the DICENTIS Conference System training before you install, configure, prepare, and operate a DICENTIS Conference System.

The DICENTIS Conference System is an IP based conference system which runs on an OMNEO compatible Ethernet network. It is used for distributing and processing audio, video and data signals.

The DICENTIS Conference System can be quickly and easily configured as a daisy-chain configuration or as a star configuration:

- **Daisy-chain configuration:** Uses dedicated cabling, consisting of CAT-5e cables including two additional power conductors (see *Typical system setup, page 10*).
- **Star configuration:** Each DICENTIS device is connected with an individual standard CAT-5e cable. An Ethernet switch is also required for providing Power over Ethernet (PoE).

**Notice!**

When Power over Ethernet is used, DICENTIS devices cannot be daisy-chained.

3.1 Typical system setup

This system overview does not give information on redundant network options. For more information, refer to *Redundancy options*, page 27.

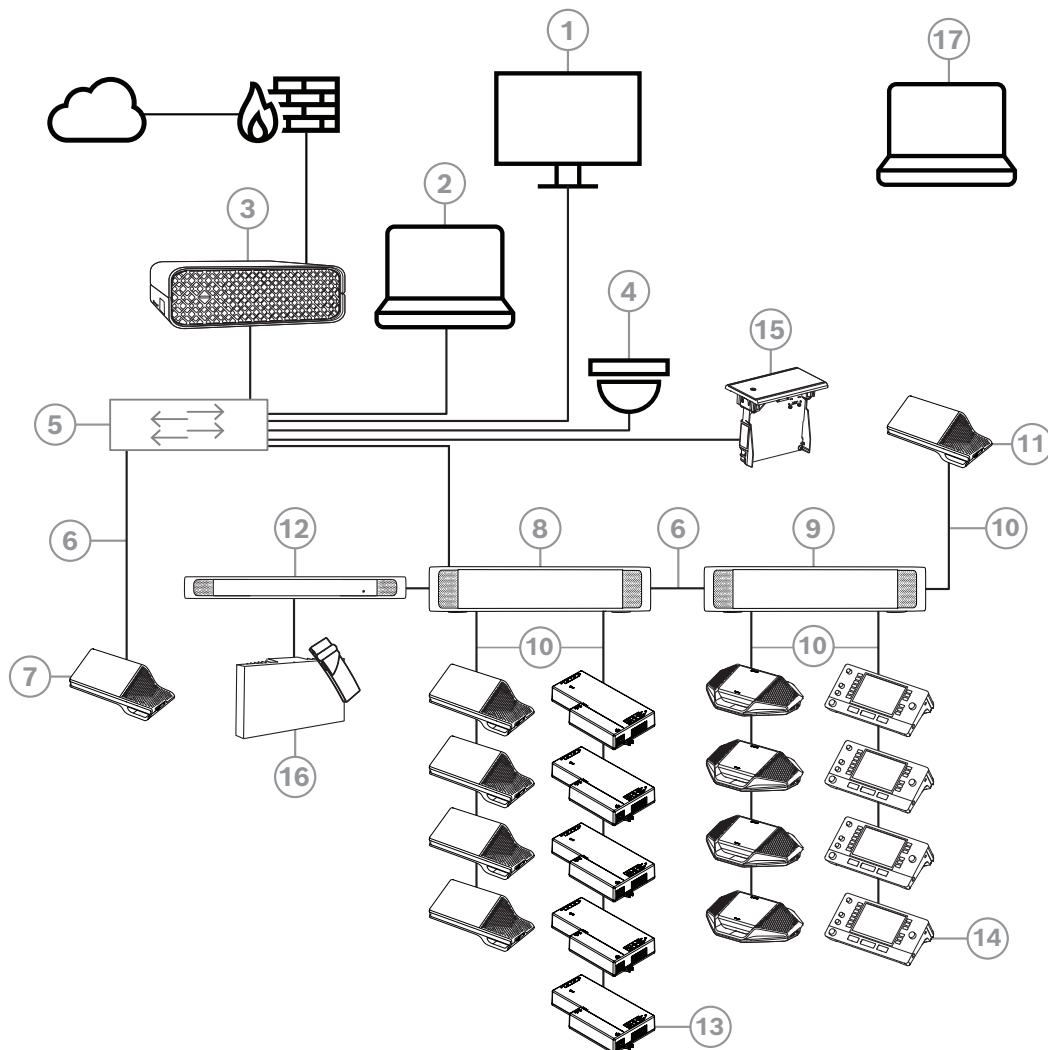

Figure 3.1: Typical DICENTIS Conference System setup

A typical DICENTIS Conference System consists of:

1. Hall display of the conference room:
 - Shows a synoptic layout of the meeting or meeting notes.
2. Client PC:
 - Can be used to: Manage meetings, prepare meetings and configure the system.
3. DICENTIS System server:
 - The heart of the system. It licenses functionality, configures and controls the system.
4. Optional video camera (Onvif Profile-S compatible cameras, Sony IP cameras via CGI commands, or Panasonic HD Integrated IP) + external power supply:
 - Captures the image of a speaking participant.
5. Ethernet switch:
 - Ethernet switch with PoE on some ports.
 - Routes de system data via Ethernet.
 - Provides power to the DICENTIS devices via PoE.
6. CAT-5e Ethernet cable (minimum requirement).

7. Multimedia device:
 - Only one DICENTIS device should be connected here.
8. Powering switch:
 - Used to increase the number of DICENTIS devices connected to the system.
9. Audio processor and powering switch:
 - Controls the system audio, routes audio from and to the system and supplies power to the DICENTIS devices.
10. System Network Cable:
 - Connects DICENTIS devices, the Audio processor and powering switch, and one or more Powering switches to each other.
11. Multimedia device:
 - This device is used for “system power on/off”. It is always connected to the powered socket of the Audio processor and powering switch or Powering switch.
Note: Only one DICENTIS Multimedia device should be connected here.
12. Transmitter OMNEO:
 - This device allows for wireless language distribution.
13. Flush base device:
 - This device is intended for use in flush-mounted solutions, adding a number of functions.
14. Interpreter Desk:
 - Provides extensive facilities for professional interpretation for the DICENTIS Conference System.
Note: A maximum of 10 desks can be installed per booth.
15. Flush language selector:
 - This device allows the participants to easily choose their preferred language.
16. IR distribution:
 - Through infrared distribution, the signals from the INT-TXO are transmitted to the radiators in the room.
17. Laptop:
 - Used by a meeting participant joining remotely.

A typical camera setup in a DICENTIS Conference System consists of:

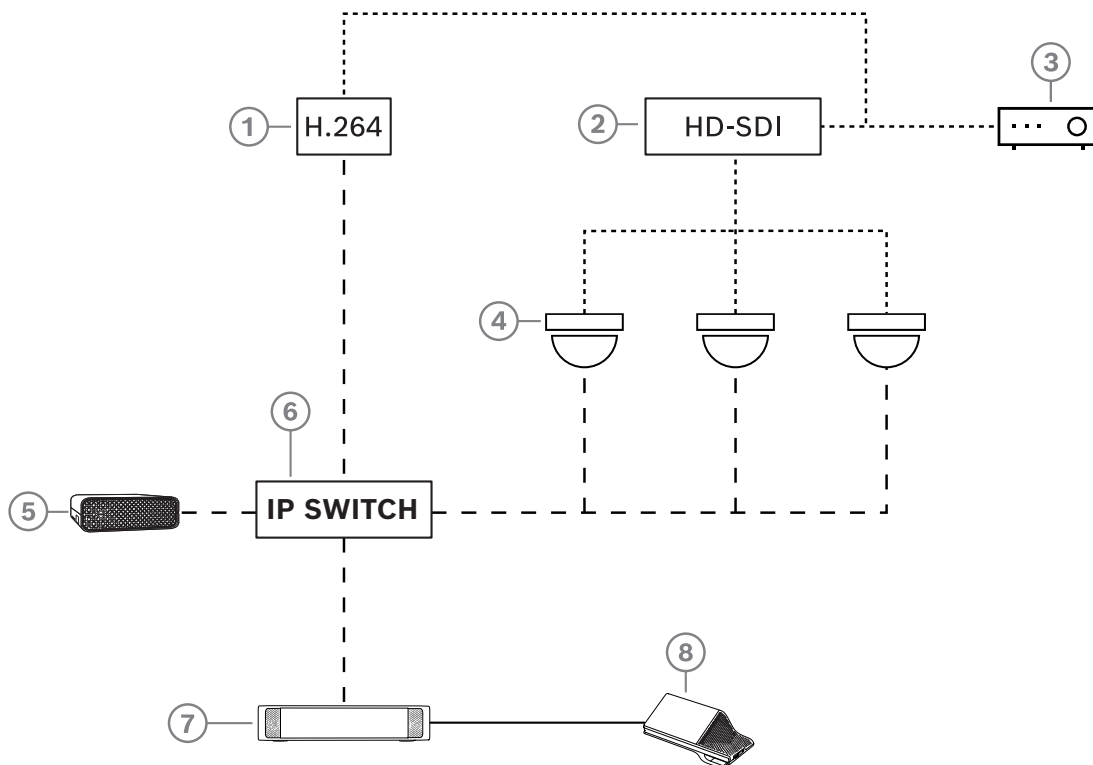

Figure 3.2: Typical camera setup

1	H.264 encoder to encode the HD SDI video to H.264 if the video camera is not able to supply the supported H.264 stream	2	HD-SDI switcher to switch the HD-SDI streams of the cameras
3	Projector to show the active speaker on the large screen	4	Video camera (Onvif Profile-S compatible camera, Sony, Panasonic)
5	DCNM-SERVER3	6	L3 Ethernet switch
7	DCNM-APS2	8	DCNM-MMD2, displaying the active speaker on the device
.....	HD-SDI (coax cable)	-----	Ethernet TCP/IP
_____	DCNM-Cables		

3.2 System extension

The DICENTIS Conference System is scalable from small to medium to large. This section describes what a small, medium and large system is and what the requirements are for these systems:

A small to medium DICENTIS Conference System (see *Typical system setup, page 10*) consists of:

- up to 450 DICENTIS nodes.
Refer to table **Node and device count of DICENTIS equipment** below about the node and device count of DICENTIS equipment.
- all DICENTIS devices in 1 subnet.
- 1 DICENTIS Audio processor and powering switch for the audio processing.
- 1 Server PC which hosts the DICENTIS services.

A large DICENTIS Conference System consists of:

- up to 1500 DICENTIS devices.
- multiple subnets connected by use of a router/L3 switch.
 - Each subnet can have up to 450 DICENTIS nodes.
Refer to the following table for the node count of DICENTIS equipment.
 - The first subnet has:
 - 1 DICENTIS Audio processor and powering switch for the audio processing.
 - 1 Server PC which hosts the DICENTIS services.
 - 1 ARNI-Enterprise to increase the size of the system.
 - All other subnets have 1 ARNI-Standard to increase the size of the system.
Note: There is no DICENTIS Audio processor and powering switch in the other subnets.

Device	Node count	Device count	IP addresses
DICENTIS Server	0	0	1
DICENTIS meeting application	0	0	0
DICENTIS Audio processor and powering switch	1	1	1
DICENTIS Powering switch	1	1	1
DICENTIS Multimedia device	2	1	2
DICENTIS Discussion device	1	1	1
DICENTIS Discussion device select language	1	1	1
DICENTIS discussion device voting	1	1	1
DICENTIS Discussion device extended	1	1	2
DICENTIS Interpreter desk	1	1	2
DICENTIS Interpreter desk with video	1	1	3
DICENTIS Flush base device 2	1	1	1
DICENTIS Flush language selector	1	1	1
INT-TXO Transmitter OMNEO	1	1	2

Device	Node count	Device count	IP addresses
OMN-DANTEGTW Dante gateway	1	0	1
PRS-4OMI4 OMNEO media interface	1	0	1
OMN-ARNIE ARNI-E OMNEO interface	0	1	1
OMN-ARNIS ARNI-S OMNEO interface	0	1	1

Table 3.1: Node and device count of DICENTIS equipment

An ARNI (Audio Routed Network Interface) is used to connect multiple DICENTIS system subnets. If more than one subnet is required, two types of an ARNI must be used.

- OMN-ARNIS (ARNI-S OMNEO interface): The ARNI-S is required for increasing the system size above 450 DICENTIS nodes. It supports up to 450 DICENTIS nodes in its subnet. It also acts as a DHCP server in its subnet.
- OMN-ARNIE (ARNI-E OMNEO interface): The ARNI-E is required for increasing the system size above 450 DICENTIS nodes. It supports up to 450 DICENTIS nodes in its subnet. It also acts as a DHCP server in its subnet. It can connect up to 40 subnets, each with an ARNI-S.

Defining subnets and subnet masks

A subnet is a logical, visible subdivision of an IP network. The number of DICENTIS devices that can be in the same subnet depends on the subnet mask.

A standard class C subnet (255.255.255 or /24) can contain 254 IP addresses. Some DICENTIS devices have 2 IP addresses. For this reason, Bosch advises to use 255.255.252.0 (or /22) as a subnet mask. This allows you to have 1018 IP addresses.

Multi subnet DICENTIS Conference System

The following figure illustrates a typical multi subnet DICENTIS Conference System with a total of 1500 DICENTIS devices.

- The system is divided over four (4) subnets, where two (2) subnets having a maximum of 450 DICENTIS nodes and an OMN-ARNIS are connected.
- The system has one OMN-ARNIE installed in the first subnet with a maximum of 450 DICENTIS nodes connected (Note that only one OMN-ARNIE is allowed within a multiple subnet DICENTIS Conference System).
- Subnet four (4): When using multiple subnets, make sure that all cameras needed to capture video of the seats are all connected to the same subnet.

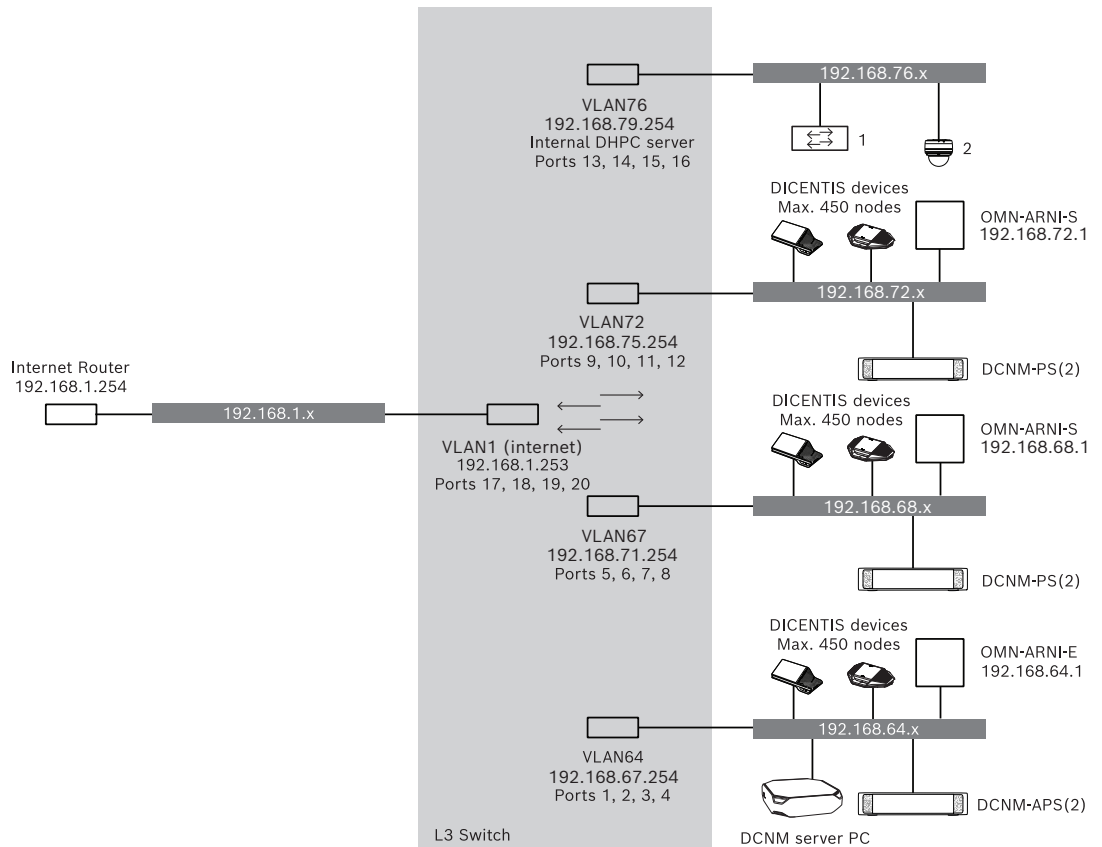

Figure 3.3: Typical DICENTIS Conference System with multiple subnets

- **1:** External video switcher.
- **2:** Dome camera.

Refer to

- *Typical system setup, page 10*

4 System installation design and planning

Before you start to install system devices and connect system cabling, you should make a system design and planning:

- Familiarize yourself with the product and system capabilities.
- Make a cable (connection) plan:
 - Calculate the system network cable length.
 - Calculate the system power consumption.
 - Calculate the required power capacity of the system.

**Notice!**

The DICENTIS Conference System uses the RSTP protocol when redundant cabling mode is enabled. If the DICENTIS Conference System needs to be connected with the locally present network, please consult the local IT department before continuing with the installation design.

**Notice!**

Make sure that the cable lengths and power consumptions do not exceed the specifications. Not doing so will result in malfunctioning at any moment of the DICENTIS Conference System and products.

**Caution!**

When the relative humidity is below 40%, synthetic materials can cause static discharge and result in malfunctions.

4.1 System capabilities

The capability of the DICENTIS Conference System and DICENTIS products depends on:

- The lengths of the system network cables.
- The number of connected devices.
- The system power supply capacity.

Cable length

System network cables (DCNM-CBxx-I) lengths (2, 5, 10 or 25 m) have a direct effect on the available power supply capacity. The longer the system network cable, the less power supply capacity is available to drive the connected devices. Therefore, choose the lengths of the system network cables carefully.

**Notice!**

Custom network cables must never exceed the maximum Ethernet specification of 100m (IEEE 802.3ab).

Keep your network hierarchy as flat as possible. This means having as few levels as possible. It is recommended not to exceed 7 levels. See the following example: 1: 1st level = Root switch, 2: 2nd level = switch, 3: 3rd level = switch.

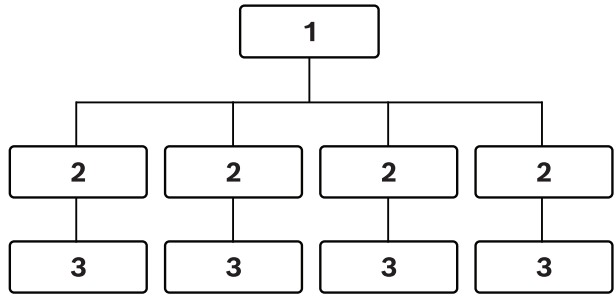

Figure 4.1: Example: Switch-levels

Power supply capacity

The total system network cable length and connected devices determine the required power supply capacity. The power within the DICENTIS Conference System is supplied by:

- The Audio processor and powering switch and the Powering switch, or
- Off-the-shelf PoE Ethernet switches.

Calculation tool

The calculation tool can be used to calculate the total power capacity of the system. This makes the design and planning of the DICENTIS Conference System easier. The calculation tool uses the power consumption of the devices and the system network cable lengths to calculate the needed system power supply capacity.

The calculation tool is on the DVD supplied with the Audio processor and powering switch and is part of the DICENTIS software DCNM.iso file. The DCNM.iso file can be downloaded from the Bosch website at: <https://licensing.boschsecurity.com/software>

4.2 Hardware requirements

Switches

The following minimum requirements and recommendations apply to switches used in a DICENTIS:

Requirement	Standard	Settings
Gbit Ethernet	IEEE802.3	Switch latency is maximally 10µSec with Gbit. Valid for both copper and/or fiber ports.
Packet forwarding in HW per port >1.2Mpps	n.a.	If SW is responsible for packet switching, this would result in variable latency which is unacceptable.
Quality of Service With strict priority	DiffServ	To make sure PTP synchronization packets and audio packets get priority over control packets. OMNEO uses QoS on IP level to avoid synchronization and audio problems on busy networks. Although the system does work without problems on relatively quiet networks (< 10% network load) it is important to configure your network switches correctly. The used QoS is Differentiated Services or DiffServ, which is part of the Type of Services field (ToS) in the IP header. For more details on DiffServ & IP header, see Wikipedia.

Warning: IEEE802.1p is also used for QoS, but is limited to layer 2. Since OMNEO uses IP communication, this mechanism is not suitable, so make sure the used equipment uses DiffServ QoS!

The table below gives an overview of the used **DSCP values** which need to be configured in the switch:

Data	DSCP dec	DSCP hex	DSCP Label	TOS byte (hex)	Switch Priority queue
PTP sync, delay req	56	0x38	CS7	0xE0	Highest
PTP follow-up, delay response, audio	46	0x2E	EF	0xB8	High
(reserved)	8	0x08	CS1	0x20	Low
Control	0	0x00	Best effort	0x00	None

Warning: Please check thoroughly if your switch's highest priority queue is label as #1 or e.g. #8, because this may differ per brand. Unfortunately this is not consistent over the different brands. Setting it wrong is worse than not having priority.

Switches must be configured to support DiffServ (DSCP) quality of service The switch needs to have 4 priority queues for the DiffServ mechanism to work.		
Warning: Never use VOIP QoS settings!		
Requirement	Standard	Settings
MAC table >1000	n.a.	To avoid the switch starts broadcasting unicast packets because it runs out of space.
Disable EEE	IEEE 802.3az	Most implementations of EEE cause problems because of implementation flaws. A good implementation should work, but does not save energy since the PTP synchronization avoids this. Therefore, EEE (green or low power Ethernet) <i>must</i> always be disabled.
Disable RSTP (when no cable loops are used)		Rapid Spanning Tree Protocol (RSTP) is required when (cable) loops are created for redundancy. When no loops are created, RSTP needs to be <i>disabled</i> for optimal operation. When enabled, it can cause slow connections to the switch.
Possibility to create VLANS	n.a.	VLAN separation is recommended instead of IGMP snooping, because most switches are unable to handle the multicast changes in the system. Filtering multicast data may be necessary for some devices, such as 100 Mb devices (Sony cameras, TVOne, AMX, and others).
IGMPv3 IGMPv2 snooping in hardware		IGMPv3 or IGMPv2 snooping. To optimize bandwidth usage, IGMP snooping can be used. This is useful in systems with >10 multicast streams, although not absolutely required. Sufficient performance for handling a large number of IGMP query responses, depends on the number of (directly or indirectly) connected devices to that switch. Hardware support for IGMP snooping is strongly recommended.
Requirements when Redundant wiring is used	Standard	Settings
RSTP	IEEE802.1D-2004	RSTP is used to allow the creation of loops for redundancy. The switch must support changing the following parameters to the listed values: <ul style="list-style-type: none"> - Hello_Time = 9 seconds - Forwarding_delay = 30 seconds - Max_age = 22 seconds
Diagnostics		
Link Layer discovery	IEEE 802.1AB	For network diagnoses using Network Docent.

Requirement	Standard	Settings
SNMP	SNMP	For network diagnoses using Network Docent.

Routers

The following minimal requirements apply to routers:

- 1 Gbit or higher Ethernet ports.
- Supports PIM-DM or Bidirectional PIM.
- Performs IP routing in hardware (i.e. a ‘layer 3 switch’) to minimize the routing delay.
- Packet forwarding rate > 1,000,000 packets per second per port (e.g. 8 Mpps for an 8-port router).
- Non-blocking backplane per switching port, i.e. 2 Gbit per port (e.g. 16 Gbps for an 8-port router).
- MAC address table of at least 1000 addresses per directly connected subnet.

4.3 Power supply capacity calculation plan

How to start



Notice!

It is advisable to use the power calculation tool. The calculation tool is on the DVD supplied with the Audio processor and powering switch and is also part of the DICENTIS software DCNM.iso file, which can be downloaded from the Bosch website at: <https://licensing.boschsecurity.com/software>

Decide how to supply power to the DICENTIS devices:

- Using the Audio processor and powering switch and one or more Powering switches.
- Using one or more PoE Ethernet switches.

If you want to use PoE Ethernet switches, continue with chapter *Calculation using PoE switches*, page 25.

Refer to

- *Calculation using DCNM-APS2 or DCNM-PS2*, page 21
- *Installation material and tools*, page 31
- *Calculation using PoE switches*, page 25

4.3.1 Calculation using DCNM-APS2 or DCNM-PS2



Notice!

If you want to use customized cables, or a more accurate power supply capacity calculation plan is needed, you should use the power calculation tool.

To calculate the total power supply capacity:

1. Count all DICENTIS devices.
2. Know the exact location where the devices are installed.
3. Count each system network cable of the same length.

Device type	Power consumption (Watts)
DCNM-D	3.10
DCNM-DSL	3.60
DCNM-DVT	3.70
DCNM-DE	5.00
DCNM-MMD	11.30
DCNM-MMD2	12.00
DCNM-IDESK	15.00
DCNM-IDESKVID	18.00
DCNM-FBD2 (single seat on both sides)	8.5
DCNM-FBD2 (dual seat on both sides)	9.6

Device type	Power consumption (Watts)
DCNM-FBD2 (maximum power consumption)	11.5
DCNM-FSL	2.6*
INT-TXO	10
DCNM-CB02-I	1.19
DCNM-CB05-I	2.43
DCNM-CB10-I	4.50
DCNM-CB25-I	10.71

Table 4.2: Power consumption (Watts)



Notice!

*The DCNM-FSL is powered by PoE and not via the DCNM-APS or DCNM-PS. See *Calculation using PoE switches*, page 25 for more information.

Ordering number	Cable lengths	
	m	ft
DCNM-CB02-I	2	6.56
DCNM-CB05-I	5	16.40
DCNM-CB10-I	10	32.81
DCNM-CB25-I	25	82.02

Table 4.3: Cable types and lengths

Rear view

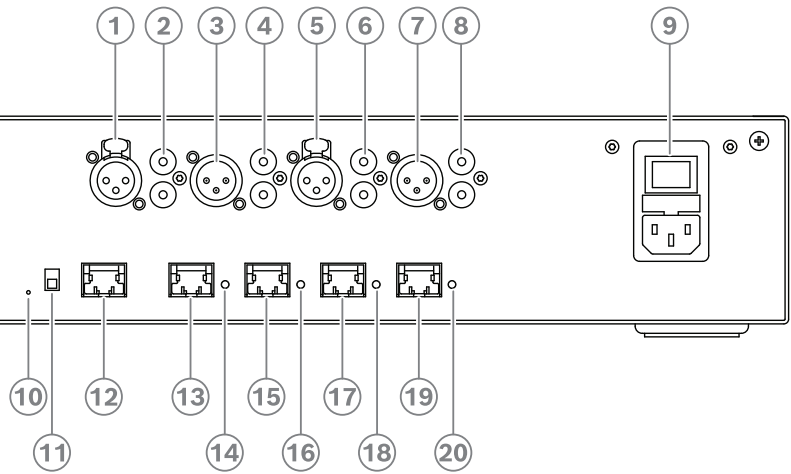

Figure 4.2: Audio processor and powering switch

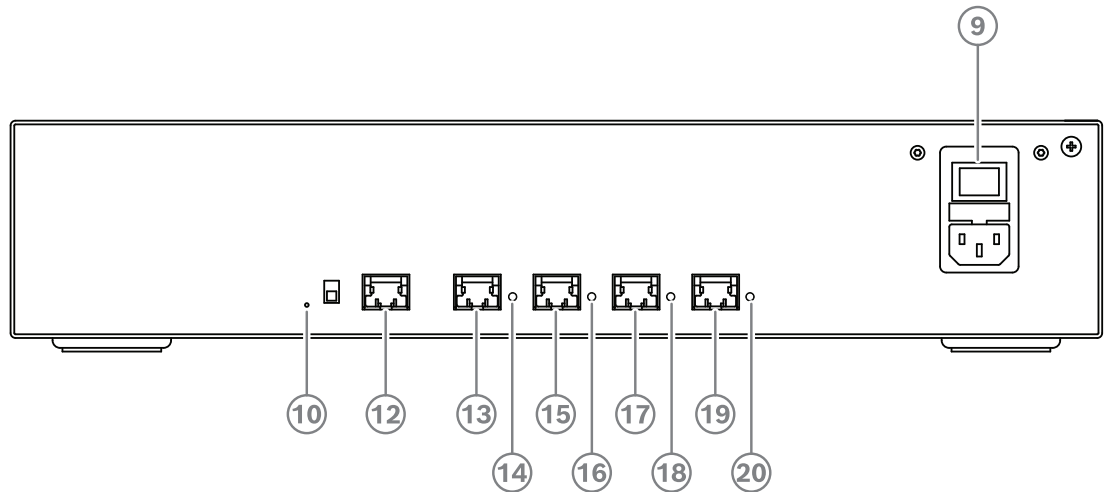

Figure 4.3: Powering switch

Item	Description
1, 5	XLR line inputs 1 and 2.
2, 6	RCA line inputs 1 and 2.
3, 7	XLR line outputs 1 and 2.
4, 8	RCA line outputs 1 and 2.
9	Mains inlet, mains switch and fuse holder.
10	Reset button.
11	Ground switch (grounded or floating).
12	Socket 1 without power.
13	Socket 2 low power.
15, 17, 19	Socket 3, 4, 5 high power.

Item	Description
14, 16, 18, 20	<p>Overload LED for sockets 2-5:</p> <p>Green: Power OK.</p> <p>Red: Overload. Remove cable and wait a few seconds for the system to reset the overload.</p>

Network and Power connector	Max. power output (W)	Max. devices
Socket 1 (12)	No power capacity	---
Socket 2 (13)	15	1
Socket 3 (15)	144	40
Socket 4 (17)	144	40
Socket 5 (19)	144	40

Table 4.4: Power supply capacity DCNM-APS2 / DCNM-PS2

Calculation examples

The following example gives you an indication of the maximum load to each socket of an Audio processor and powering switch or Powering switch.

- **Socket 2:** 50 m cable + DCNM-MMD2 = **12 W**¹
- **Socket 3:** 10 m cable + DCNM-MMD2 + 9x (2 m cable + DCNM-MMD2)
= (4.5 + 12) + 9x(1.19 + 12) = **135.21 W**².
- **Socket 4:** 10 m cable + DCNM-D + 19x (2 m cable +DCNM-D)
= (4.5 + 3.1) + 19x(1.19 + 3.1) = **89.11 W**².
- **Socket 5:** 10 m cable + DCNM-DE + 19x (2 m cable + DCNM-DE)
= (4.5 + 5) + 19x(1.19 + 5) = **127.11 W**².

¹ For socket 2, the cable power consumption of the cable does not need to be counted if only one device is connected to this output.

² The shortest redundant cable does not need to be counted.

Refer to

- *Calculation using PoE switches, page 25*

4.3.2 Calculation using PoE switches

Select one or more PoE Ethernet switches to supply power to the DICENTIS devices. Each DICENTIS device must be connected to an individual PoE enabled output of an Ethernet switch.



Notice!

Some PoE Ethernet switches can only supply power to a limited number of ports. Others can supply power to every port, but the total power the Ethernet switch can supply is limited. Please consult the documentation of the PoE Ethernet switch used.



Notice!

Using PoE, DICENTIS devices cannot be daisy-chained connected. Using PoE does not provide redundant cabling.

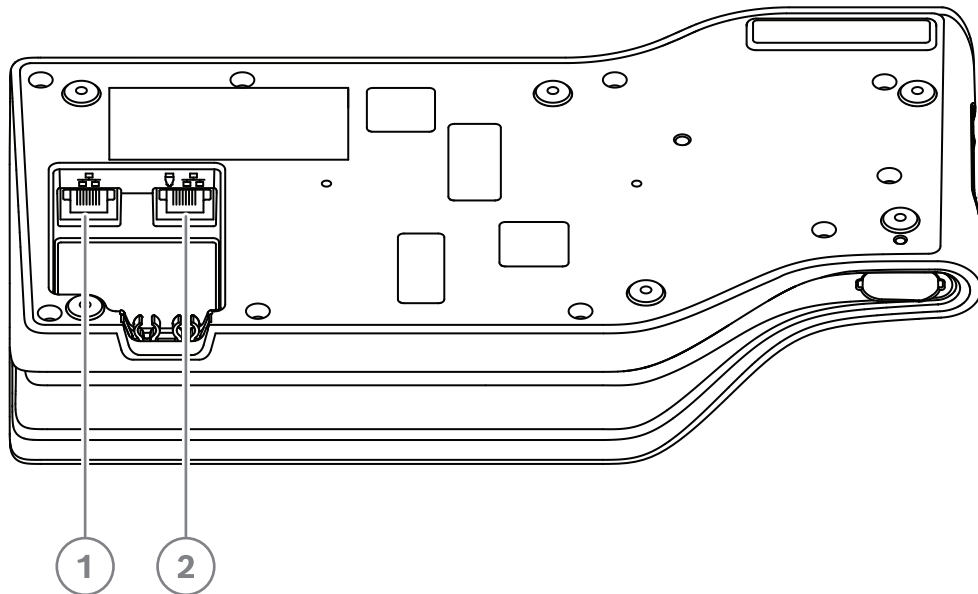

Figure 4.4: Bottom view DICENTIS devices (DCNM-MMD / DCNM-MMD2)

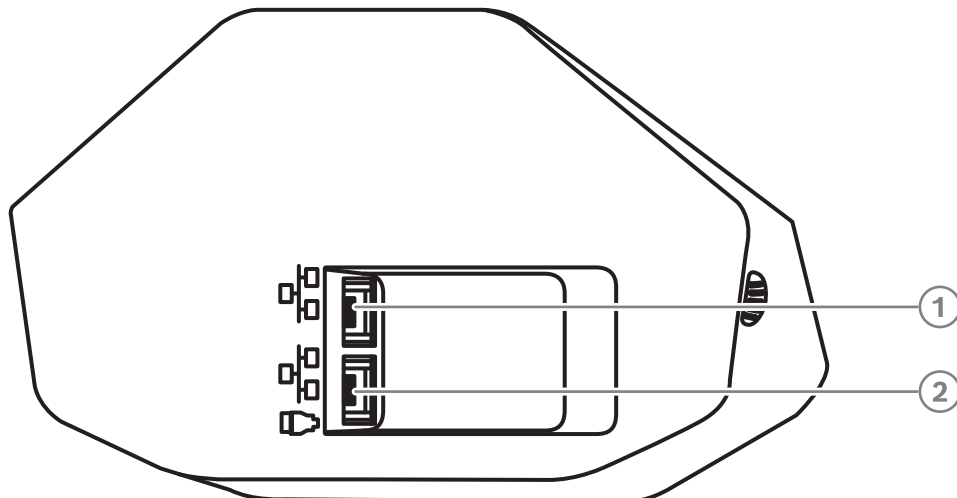

Figure 4.5: Bottom view DICENTIS devices (DCNM-D / DCNM-DVT / DCNM-DSL / DCNM-DE)

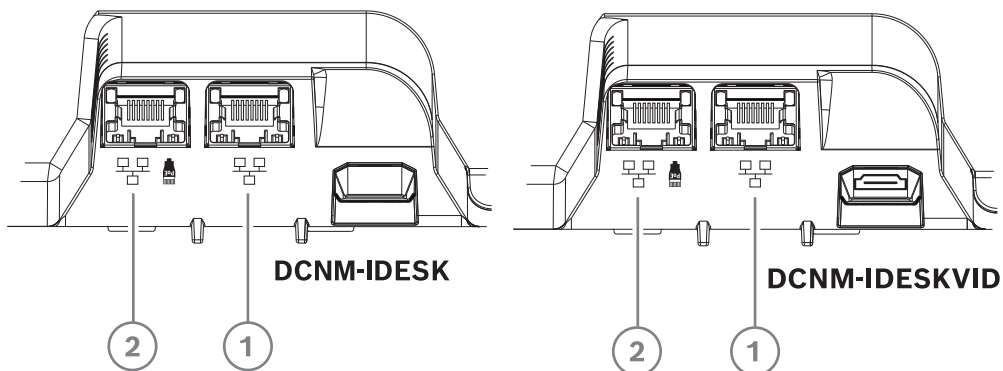

Figure 4.6: Bottom view DICENTIS Interpreter devices (DCNM-IDESK / DCNM-IDESKVID)

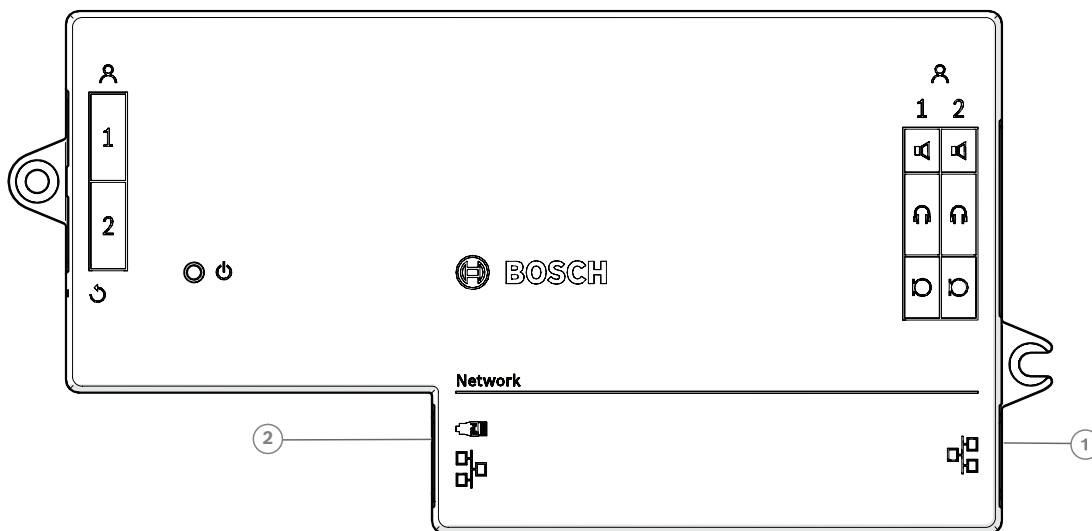

Figure 4.7: Topview view DICENTIS Flush base device (DCNM-FBD2)

Item	Description
1	Network connector
2	Network / PoE connector

4.4 Redundancy options

DICENTIS Conference Systems can be created with network redundancy. This ensures that the system will continue to work if:

- a network cable is defective or accidentally disconnected.
- one of the components fails.

Different levels of redundancy can be created in the system depending on:

- the type of unit used in the system (DCNM-APS2 / DCNM-PS2)
- the number of redundant components used in the system.
- the amount of redundant network cabling.

The following sections explain the redundancy options that can be used when designing your DICENTIS Conference System. Each option can be combined in the DICENTIS Conference System, providing you observe the redundant cabling limitations. Refer to:

- *Redundant cabling for DCNM-APS2/DCNM-PS2 units, page 28.*
- *Redundant server PC, page 30.*

**Notice!**

Rapid Spanning Tree Protocol (RSTP) must be enabled in the DICENTIS Conference System for these redundancy options to work correctly.

**Notice!**

Follow these steps when setting up redundancy options for your system:

First, set up your system without cable redundancy and RSTP configuration in the system and DICENTIS.

Secondly, configure RSTP in the switches and DICENTIS.

Thirdly, enable the cable loops.

4.4.1 Redundant cabling for DCNM-APS2/DCNM-PS2 units

This section describes how to create redundant cabling for DCNM-APS2 / DCNM-PS2 type units. The maximum number of Ethernet devices in the largest possible loop (including the root switch) is 22. In a system with no Ethernet switch(es), the APS is the root switch.

The total number of devices allowed in a loop depends on:

- The type of device connected in the loop (for example, DCNM-MMD2 devices consume more power than DCNM-DE devices).
- The length of the loop (cable also consumes power).

The figure shows how to calculate the number of devices in the loop. The grey line shows the largest loop. The # sign shows the way the devices are counted.

In the example below up to 19 (22 - 3 = 19) discussion devices can be connected.

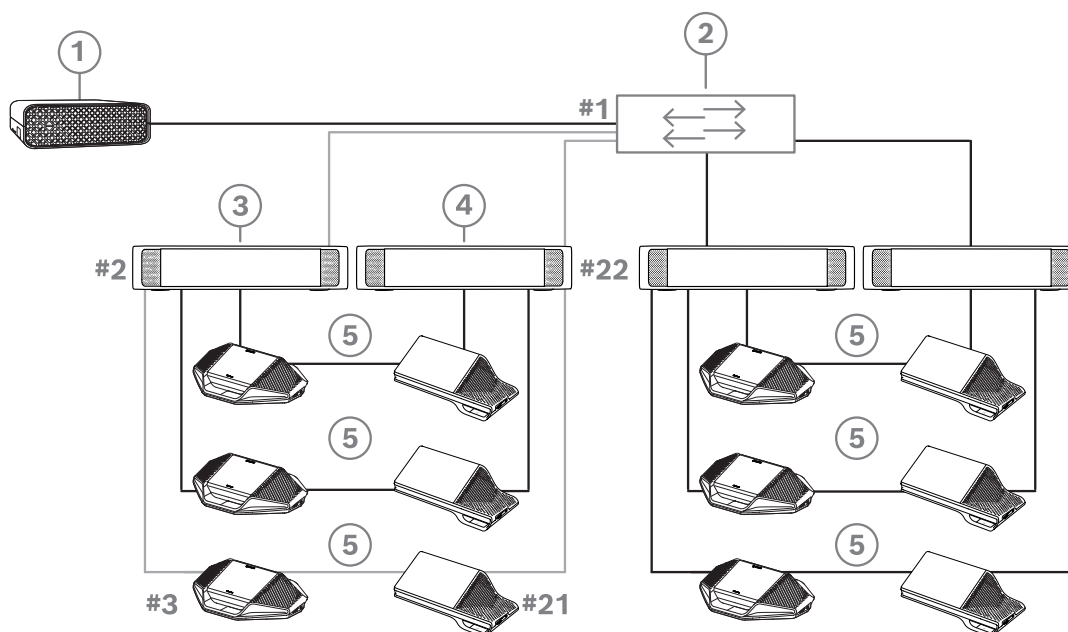

Figure 4.8: DICENTIS discussion devices connected with redundant cabling between DCNM-PS2 / DCNM-APS2 type units

1	DICENTIS system	2	Network switch (with optional redundant power supply)
3	DCNM-APS2	4	DCNM-PS2
5	DICENTIS cabling (redundant loop)		

Maximum number of DICENTIS devices in a string:

- The max age timer should be set to 22 when RSTP is used for cable redundancy to prevent a defective cable or powering switch from influencing the system.
- Each time data hops from one switch to another, the age is increased by one. This timer can be reached or exceeded, because a daisy chain can be used to loop through the DICENTIS devices.
- This timer (or restriction) cannot be reached when there is no cable redundancy. This is because the power limitation will be reached before the max age restriction is reached.
- The timer can be reached when:
 - you use cable redundancy,
 - the system is incorrectly wired.

Cabling possibilities (DCNM-APS2/DCNM-PS2)	Limitations/requirements
<p>Create a redundant loop by connecting the DICENTIS devices in a daisy chain configuration from a high power socket on a DCNM-PS2 / DCNM-APS2 to a high power socket on another DCNM-PS2.</p> <p>The redundant loop between two DCNM-PS2 units is for power and signal. If one of the DCNM-PS2 units fails, the other DCNM-PS2 unit will supply power and signal to the DICENTIS devices in the daisy chain.</p>	<p>The redundancy is for power and control. If the DCNM-APS2 fails, the devices remain connected, but audio is lost.</p> <p>To enable redundancy:</p> <ul style="list-style-type: none"> - Rapid Spanning Tree Protocol (RSTP) must be enabled in the DICENTIS Conference System. - a network switch with redundant power supply, should be connected to the DCNM-PS2 / DCNM-APS2 units, as shown in the previous figure.
<p>You can use any of the high power sockets (3, 4, or 5) on either of the DCNM-PS2 units to create the daisy chain/redundant loop. For example, high power socket 3 on one unit can be connected to high power socket 4 on another unit.</p>	<p>Note: The redundant loop must be connected to another DCNM-PS2 type unit. You cannot use DCNM-PS / DCNM-APS type units to create redundant loops for power.</p>
<p>You can create a redundant loop for signal only, by connecting the DICENTIS devices in a daisy chain configuration to the same DCNM-PS2 or DCNM-APS2, although this is not recommended.</p> <p>The DCNM-PS2 unit is designed to reduce cost of ownership, for example, by allowing a maximum of three redundant loops to be connected between two DCNM-PS2 units.</p>	<p>The redundant loop will protect against cable outages, but not against failure of a DCNM-PS2.</p>



Notice!

Rapid Spanning Tree Protocol (RSTP) must be enabled in the DICENTIS Conference System for these redundancy options to work correctly.

4.4.2 Redundant server PC

System availability can be improved by connecting a redundant DICENTIS server PC and the associated components and cables to the DICENTIS Conference System. The maximum number of Ethernet devices in the largest possible loop (including the root switch) is 22.

The total number of devices allowed in a loop depends on:

- The type of device connected in the loop (for example, DCNM-MMD2 devices consume more power than DCNM-DE devices).
- The length of the loop (cable also consumes power).

The figure shows how to calculate the number of devices in the loop. The grey line shows the largest loop. The # sign shows the way the devices are counted.

In the example below up to 17 (22 - 5 = 17) devices can be connected.

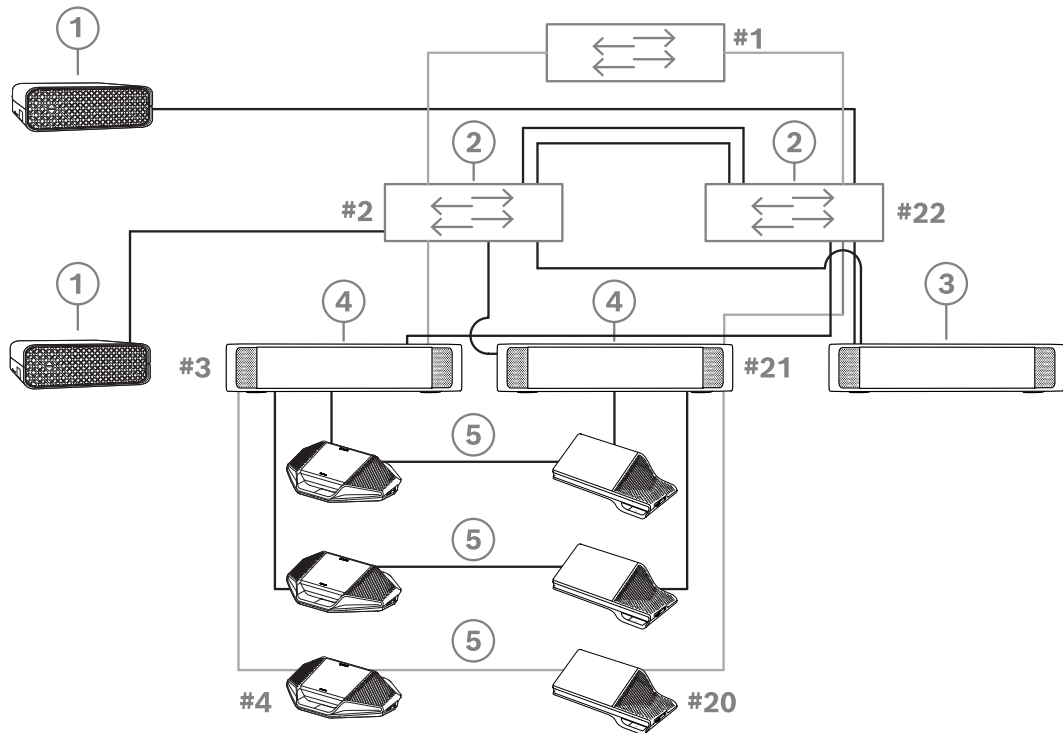

Figure 4.9: Redundant DICENTIS server PC with redundant components and cables

1	DICENTIS system	2	Network switch (with optional redundant power supply)
3	DCNM-APS2	4	DCNM-PS2
5	DICENTIS cabling (redundant loop)		

For this option to work the DICENTIS Conference System has to be run in combination with EverRun Enterprise software from Stratus Technologies. For more information, refer to the Stratus Technologies website.

Other options that can be used for guaranteeing the reliability of the DICENTIS Conference System include:

- Remote SQL servers.

5 Installation material and tools

This section describes installation material such as cables, connectors and tools.

Recommendations

- Always use manufacturer specified installation products, materials and tools.
- In general, use different cable ducts for the system network cables, audio cables and mains supply cables.
- In public areas where people can touch or move above the connectors and cables, use metal protection covers.



Warning!

Do not exceed the bend limitations of system network cables (DCNM-CBxxx):
The minimum bend radius of the system network cable is a 35 mm radius.

5.1 DCNM-CBCPLR Cable couplers

Cable couplers can be used:

- to extend cables,
- in a floor pod as break-out box,
- as an interface between DICENTIS cable and “standard” CAT-5E cable combined with a separate power cable,
- to insert power locally to the participant devices,
- to switch the system on by using two cable couplers and a switch.

Cable couplers are delivered in a box that contains 6 cable couplers. They can be used for all types of DICENTIS cables.

Mounting

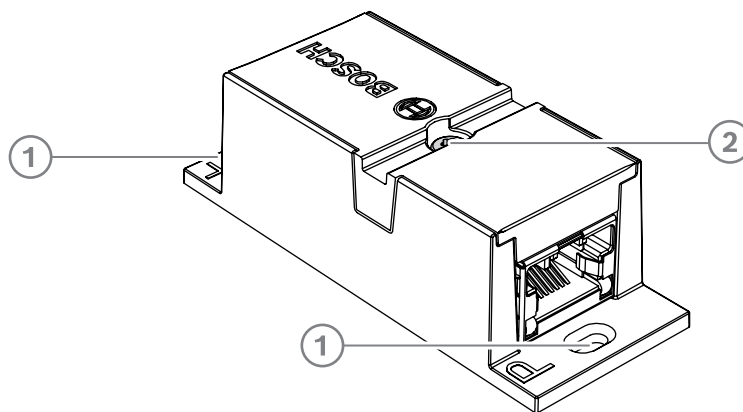

To secure the DCNM-CBCPLR to a flat surface, insert two 2.5 mm screws in the existing holes on the flaps (1). You can also fix the DCNM-CBCPLR by wrapping a cable tie around the device using the existing recess (2) to prevent side movement.

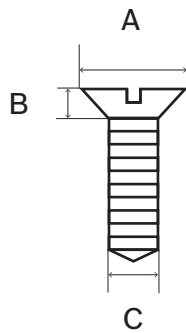

Figure 5.1: Screw max dimensions

	Flat head
A	8 mm
B	2 mm
C	2.5 mm

5.1.1

Using a cable coupler to extend a cable

The DICENTIS Cable coupler can be used to extend cables, as it allows you to connect DICENTIS Cable assemblies together. This way, it is possible to connect, for example, three 25 m (DCNM-CB25-I) cables together to form a 75 m cable.

Note:

- The cable length is not allowed to exceed 100 m.
- No more than 2 cable couplers can be used in one trunk.

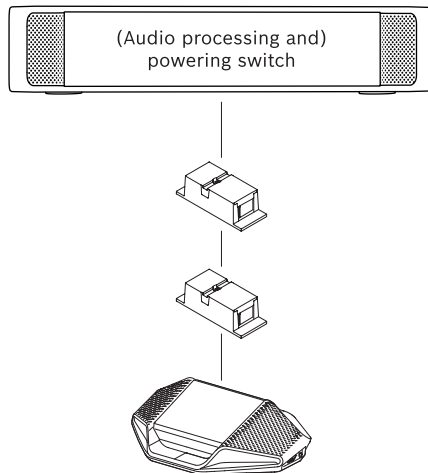

5.1.2

Using a cable coupler as a break-out box

The DICENTIS Cable coupler can be used in a floor pod as a break-out box, for example, if you want to connect temporary devices like a rostrum microphone. The cable coupler can be fixated using the screw holes (2.5 mm) or via a tie wrap through the recessed area.

Note:

- The cable length is not allowed to exceed 100 m.
- No more than 2 cable couplers can be used in one trunk.

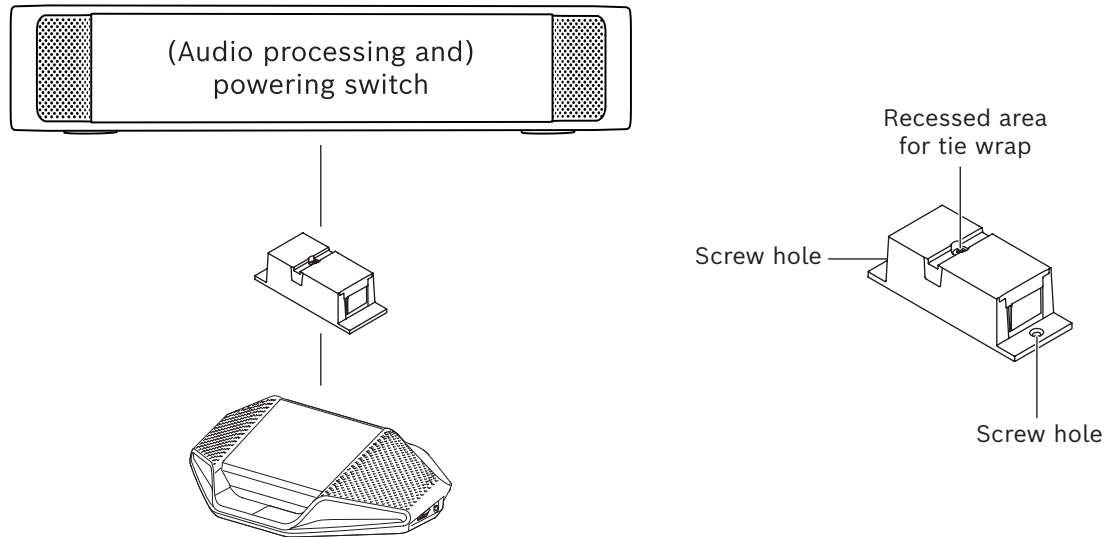

Figure 5.2: Installation in a floor pod as break-out box

5.1.3

Using a cable coupler as an interface between different types of cable

The cable coupler can be used as an interface between DICENTIS cable and “standard” CAT-5E cable, optionally combined with a separate power cable. This can be used, for example, when standard CAT-5E cabling coming from the technical room has to be connected with DICENTIS cable in the conference room.

To set this up:

1. Open the housing of the cable coupler.
2. Connect the power cables to the screw terminals + and -.
3. Remove the break-out of the housing to guide the power cables through.
4. Create a tension release.



Warning!

Risk of electric shock. Exposed power cables are a potential hazard. Make sure all power cables are securely fastened by fixing them with a tie wrap on the inside of the box (see drawing ‘Creating a tension relief’).

5. Close the housing and fix the screw with torque 0.4 Nm.

Note:

- The cable length is not allowed to exceed 100 m.
- No more than 2 cable couplers can be used in one trunk.
- Use a 20 AWG (0.5 mm²) cable

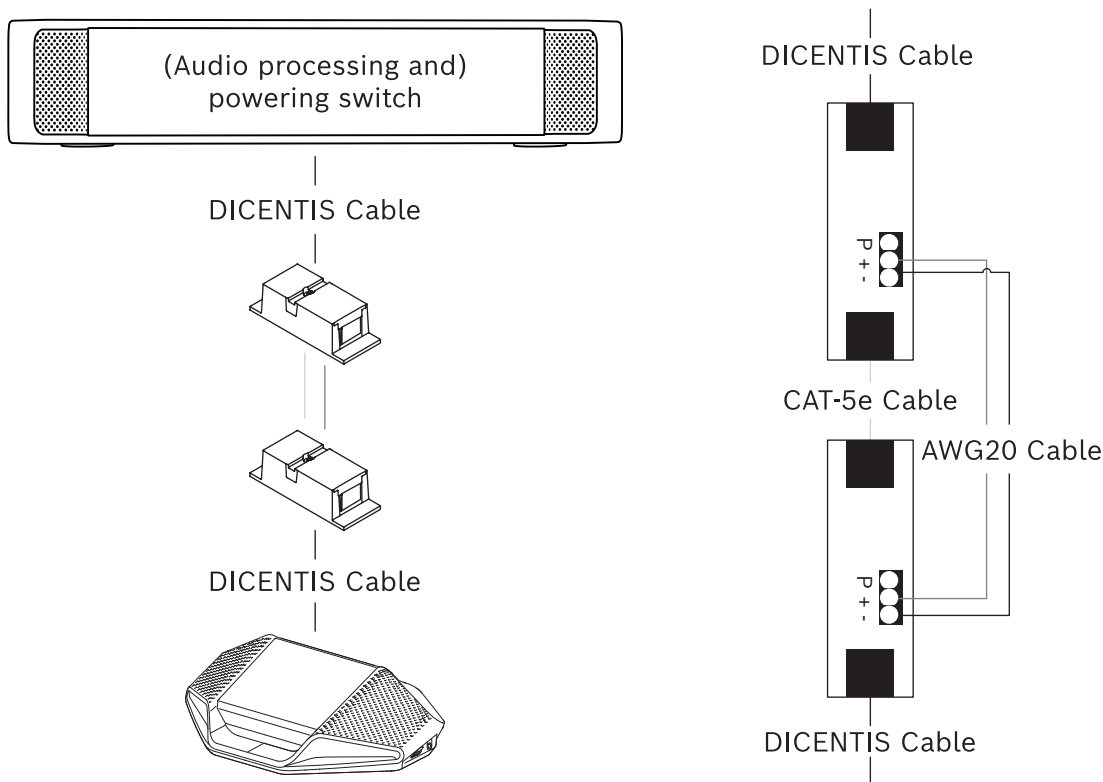

Figure 5.3: Cable coupler used as interface

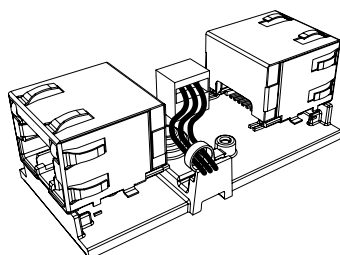

Figure 5.4: Creating a tension relief, tie wrap prevents the power cables from being pulled out accidentally.

5.1.4

Using a cable coupler to insert power locally

The cable coupler can be used to insert a local power supply, enabling you to place a third-party 48 VDC power close to the participant devices.

To set this up:

1. Open the housing of the cable coupler.
2. Connect the power cables to the screw terminals + and -.
3. Remove the break-out of the housing to guide the power cables through.
4. Create a tension release.



Warning!

Risk of electric shock. Exposed power cables are a potential hazard. Make sure all power cables are securely fastened by fixing them with a tie wrap on the inside of the box (see drawing 'Creating a tension relief').

5. Close the housing and fix the screw with torque 0.4 Nm.

Note:

- Requirements for the power supply:
 - nominal output of 48 VDC (ranging from 47 - 49 VDC)
 - the ripple should be less than 200 mV pk-pk
 - maximum output current should not exceed 3.0 A (or limited to 3.0 A, because DICENTIS cables and devices have a maximum rating for this current)
- Requirement for the power cable:
 - Use a 20 AWG (0.5 mm²) cable
- Advice
 - It is strongly advised that the power supply has its own short circuit protection with a short circuit output current ranging from 4.3 to 5.0 A.
 - When the power supply has an automatic restart after a short circuit, this restart function should have an interval time of 3 to 4 seconds and should have no more than 4 restart attempts.
 - Upon powering off the power supply, the output should be less than 9 V, 1 mA.
- The maximum distance between the (A)PS and the conference device is limited to 100 m due to the Ethernet properties.

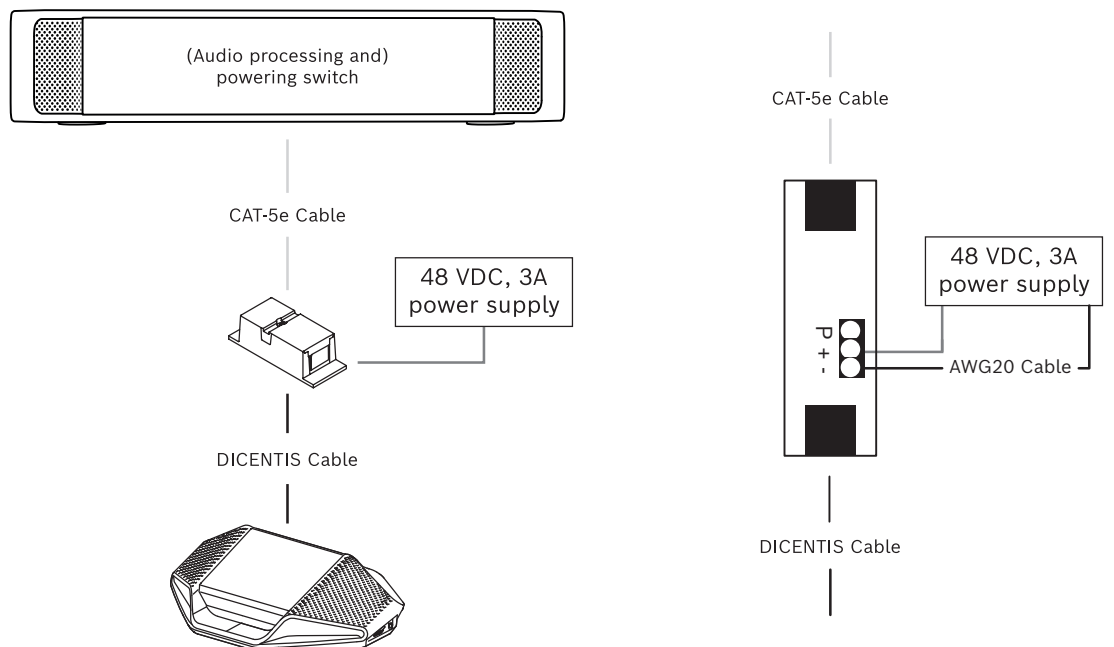

Figure 5.5: Transporting the power via cable

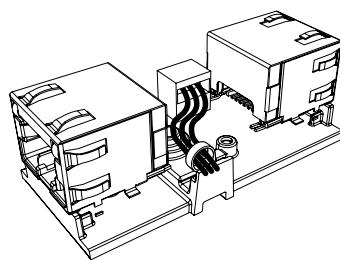

Figure 5.6: Creating a tension relief, tie wrap prevents the power cables from being pulled out accidentally.

5.1.5

Using a cable coupler to switch the system on

The DICENTIS system automatically goes into “standby” mode when:

- the option to automatically switch off the system after a period of inactivity is configured in the Meeting Application, and
- the system is not used for a specific period of time.

You can use the cable coupler in combination with a custom made switch to create a wake-up switch for the system (see following figure). To do this:

1. Open the housing of the cable coupler.
2. Remove the 0 Ohm resistor of the cable coupler connected to the always powered output. Leave the 0 ohm resistor in the cable coupler which is connected to output 3 of the (A)PS.
3. Remove the break-out of the housing to guide the power cables through.
4. Connect the wires according the figure below.
5. Create a tension release.

**Warning!**

Risk of electric shock. Exposed power cables are a potential hazard. Make sure all power cables are securely fastened by fixing them with a tie wrap on the inside of the box (see drawing 'Creating a tension relief').

6. Close the housing and fix the screw with torque 0.4 Nm.

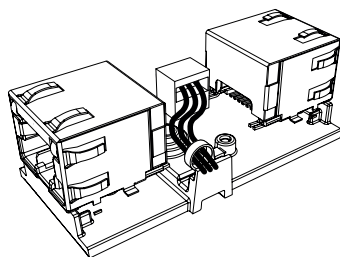

Figure 5.7: Creating a tension relief, tie wrap prevents the power cables from being pulled out accidentally.

Note:

- The cable length is not allowed to exceed 100 m.
- No more than 2 cable couplers can be used in one trunk.

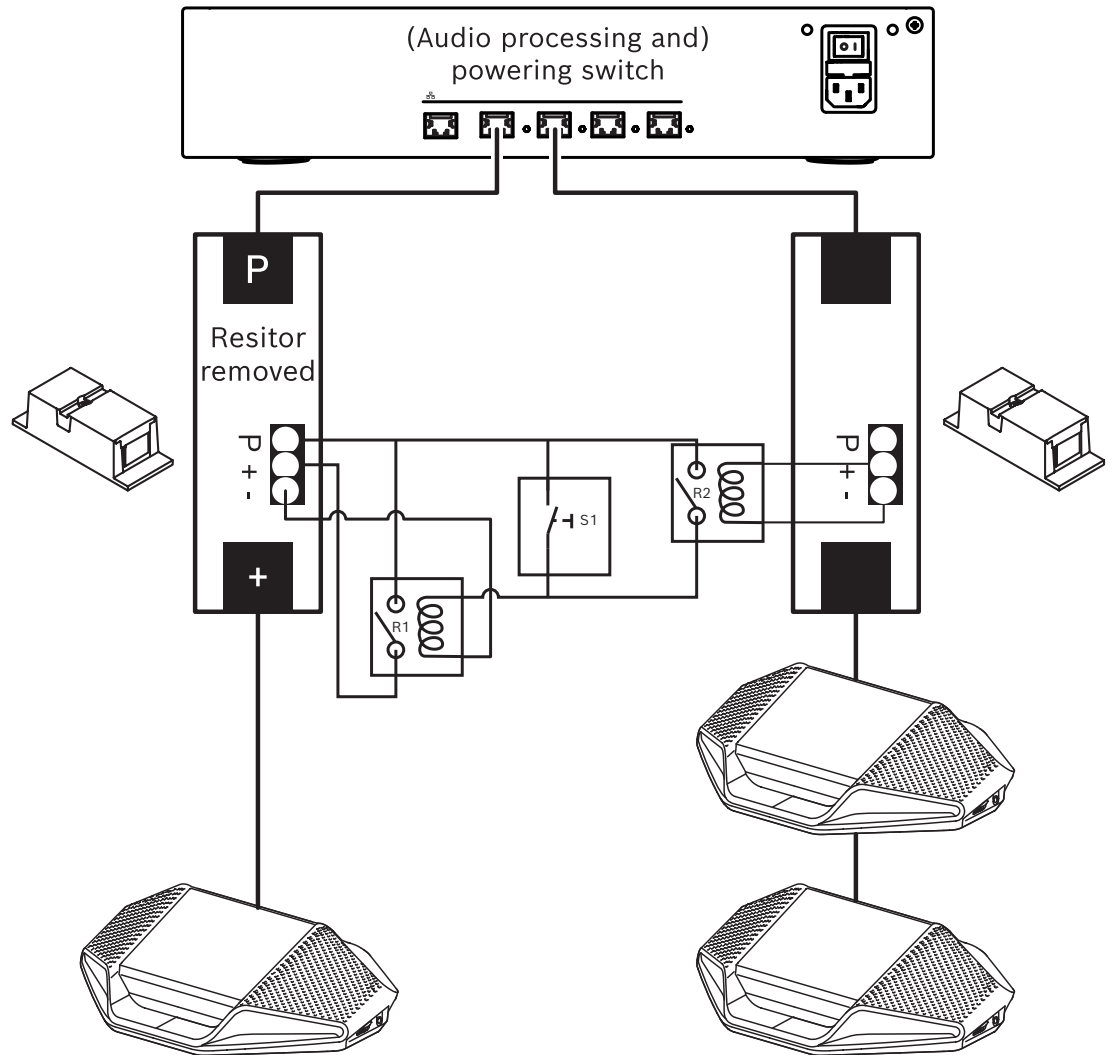

Figure 5.8: Using cable couplers and custom made switch to create a wake-up switch

The schematic works as follows:

1. By pressing S1 (pulse switch), the device connected to the always powered output receives power and powers up.
2. The device powers up and is discovered by the services. When a device is discovered, the 3.0A outputs of the (A)PS are enabled and any devices connected to these outputs are also powered up.
3. Relay R1 has a timer of 1 minute, so the switch will stay closed for 1 minute after releasing switch S1 or powering down the system.
4. When the high power trunks are powered up, the switch of relay R2 will power relay 1 to keep the switch closed.

5.2 DICENTIS System cable assemblies

The DICENTIS System Cable Assemblies, terminated with connectors on both ends, are available in different lengths and are used to connect DICENTIS devices to each other.

Ordering number	Cable lengths	
	m	ft
DCNM-CB02-I	2	6.56
DCNM-CB05-I	5	16.40
DCNM-CB10-I	10	32.81
DCNM-CB25-I	25	82.02

Table 5.5: Cable types and lengths

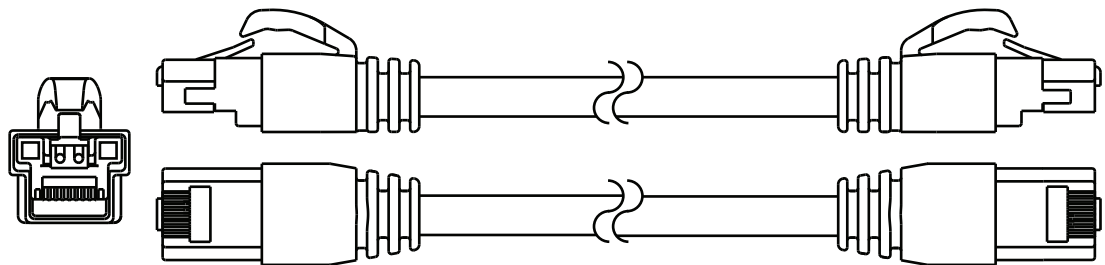

Figure 5.9: DCNM-CBxx-I cable and connector view

5.3 DCNM-CBCON Connectors for DICENTIS cable

The connectors are used to make your own system network cables or to replace a connector. The cable can be used for solid core cable (DCNM-CB02-I, DCNM-CB05-I, DCNM-CB10-I, DCNM-CB25-I, DCNM-CB250-I, DCNM-CB250), as well as stranded core cable (DCNM-CB02, DCNM-CB05, DCNM-CB10, DCNM-CB25, DCNM-CB02B, DCNM-CB05B, DCNM-CB10B, DCNM-CB25B, DCNM-CB250B).

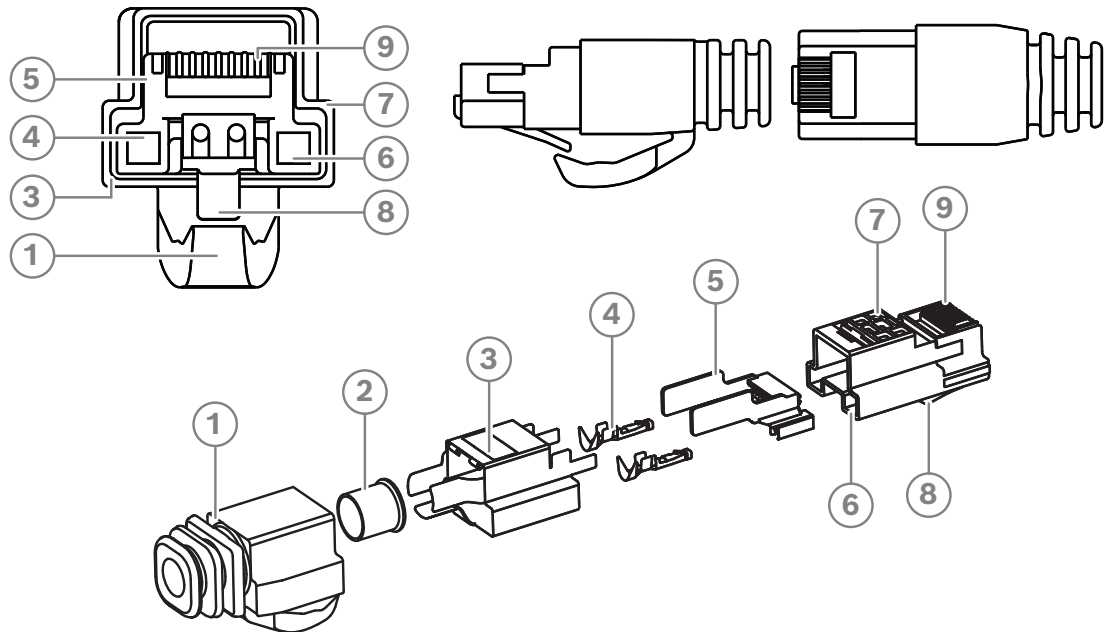

Figure 5.10: DCNM-CBCON Front and exploded view

Item	Description
1	Strain relief boot
2	Ferrule
3	Plug connector shield
4	Power contacts (Qty: 2)
5	Load bar
6	Power contact cavity (2 places)
7	Housing
8	Locking latch
9	Signal contact cavity (8 Places)

Refer to

- *DICENTIS System cable assemblies, page 38*
- *DCNM-CB250 System installation cable, page 41*
- *DCNM-CBTK System Network Cable Toolkit, page 40*

5.4 DCNM-CBTK System Network Cable Toolkit

The system network cable toolkit is used to connect the *DCNM-CBCON Connectors for DICENTIS cable, page 39* to the *DCNM-CB250 System installation cable, page 41* or *DICENTIS System cable assemblies, page 38*.

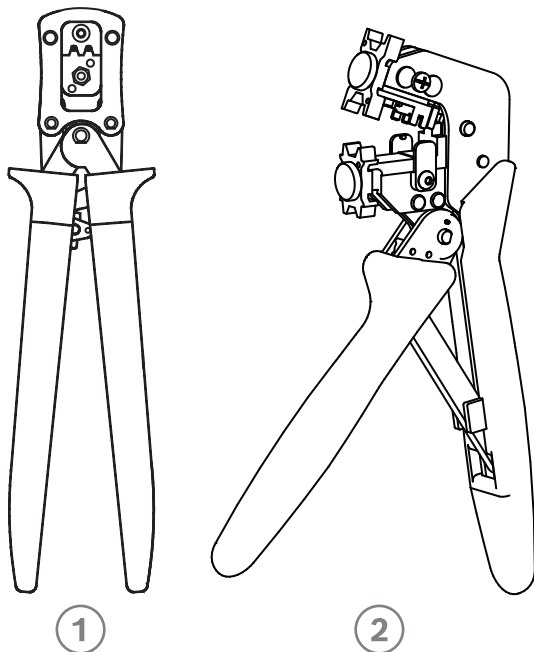

Item	Description
1	Power wiring tool.
2	Signal wiring tool.

Table 5.6: Toolkit content



Notice!

Please consult the “custom length for system network cables” section on the DVD, which can be downloaded at: <https://licensing.boschsecurity.com/software>

Refer to

- *DICENTIS System cable assemblies, page 38*
- *DCNM-CBCON Connectors for DICENTIS cable, page 39*
- *DCNM-CB250 System installation cable, page 41*

5.5 DCNM-CB250 System installation cable

The system installation cable, without connectors, is available in a length of 250 meters and is used for making your own system network cable. Refer also to the sections *DCNM-CBCON Connectors for DICENTIS cable, page 39* and *DCNM-CBTK System Network Cable Toolkit, page 40*.

The DCNM-CB250-I cable can be used to create cable assemblies and leader cables.

The DCNM-CB250-CPR complies with EN 50575:2014 + A1:2016 Reaction to fire B2a-S1a,d0,a1. Do not use DCNM-CB250-CPR if you are going to connect and disconnect it often.

**Notice!**

The maximum system network cable length is: 100 m / 328,9 ft.

**Notice!**

Please consult the “custom length for system network cables” section on the DVD, which can be downloaded at: <https://licensing.boschsecurity.com/software>

Refer to

- *DCNM-CBCON Connectors for DICENTIS cable, page 39*
- *DCNM-CBTK System Network Cable Toolkit, page 40*

5.6 DCNM-IDEKINT On-air & teleph. DCNM-IDEK

The DCNM-IDEKINT On-air & teleph. DCNM-IDEK is an accessory that is connected to the DICENTIS Interpreter desk. It has 3 functions:

- to control a booth on-air indicator outside the booth,
- to display on the Interpreter desk that the telephone system outside the booth is ringing; and
- to display on the Interpreter desk that a sensor inside the booth detects a too high CO2 level.

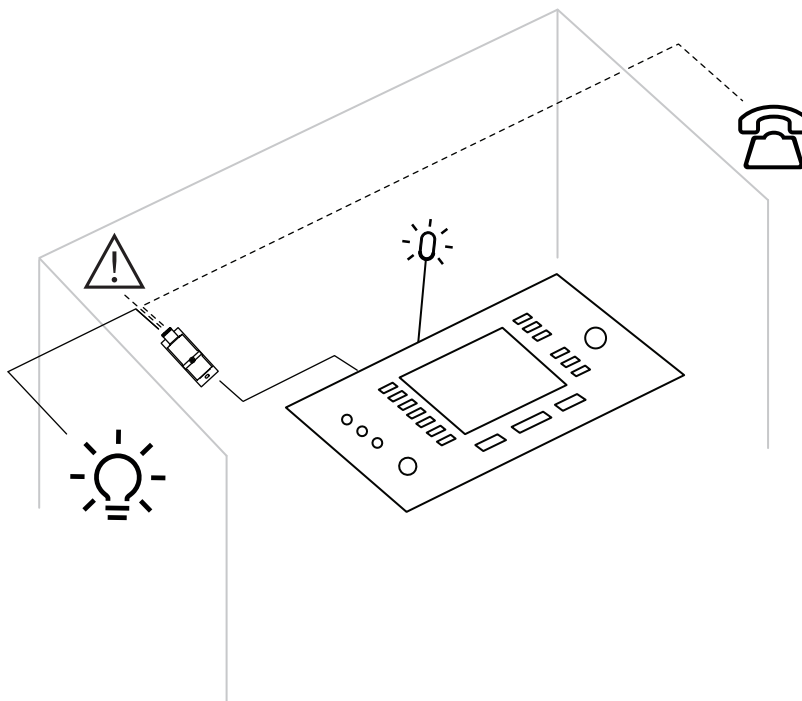

Figure 5.11: Interpreter's booth

Description of the device

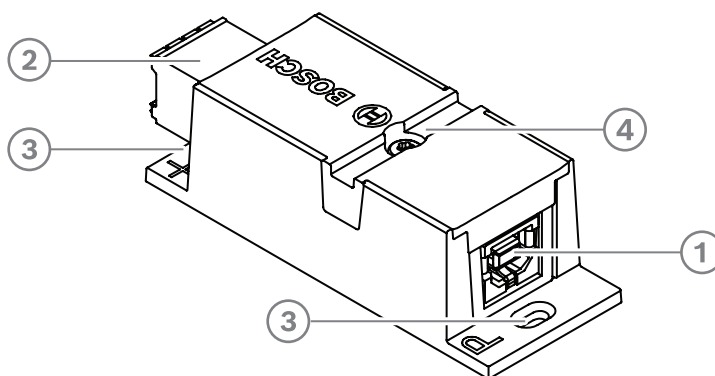

Figure 5.12: DCNM-IDEKINT

1	USB-B connector	Connects the device to the DCNM-IDEK's USB-A input
2	8-pin Phoenix connector	Connects the device to an external booth on-air LED and an external telephone system

3	Screw holes	Used to mount the device on a flat surface
4	Cable tie recess	Used to secure the device, preventing side movement

Mounting

To secure the DCNM-IDESKINT to a flat surface, insert two 2.5 mm screws in the existing holes on the flaps (3). You can also fix the DCNM-IDESKINT by wrapping a cable tie around the device using the existing recess (4) to prevent side movement.

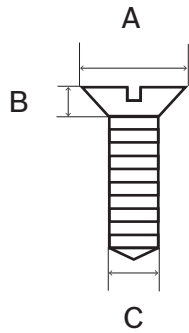

Figure 5.13: Screw max dimensions

	Flat head
A	8 mm
B	2 mm
C	2.5 mm

Connection

USB-B to USB-A

The interface is connected to the USB-A port of one of the DCNM-IDESK devices inside the interpreter’s booth. The maximum length of the USB cable is 5 m.

Note: the USB cable must be purchased separately.

8-pin Phoenix connector

The 8-pin Phoenix connector interfaces with the external telephone system and booth on-air LED. The input of the connector is used for the external telephone system, while the output is used for the external booth on-air LED. See the image and table below for reference.

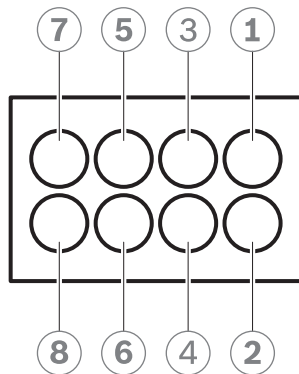

Figure 5.14: 8-pin Phoenix connector

Pin #	Function	Specifications	Description
1	Switch to set the booth on-air LED on/off	50 V/1 A potential free contact Galvanic separated	OUTPUT
2			OUTPUT
3			
4			
5	Input for an external telephone system ringing indicator	inactive: < 1 VDC active: > 3 VDC max.: 24 VDC Galvanic separated	INPUT Negative (-)
6			INPUT Positive (+)
7	Input for an external system for warning indicator	inactive: < 1 VDC active: > 3 VDC max.: 24 VDC Galvanic separated	INPUT Negative (-)
8			INPUT Positive (+)

Table 5.7: Connector pinout

Note: the female plug to be used with the 8-pin connector is supplied pre-assembled with the product. You will need to make the wire connections, which only require simple push-in action to lock.

Wiring

The connection to the Phoenix connector has to be made using ferrules.

The tables below give more details on the connection.

Conductor cross section max. (solid and flexible)	1.5 mm ²
Conductor cross section flexible, with ferrule without plastic sleeve max.	1.5 mm ²
Conductor cross section flexible, with ferrule with plastic sleeve max.	0.75 mm ²

Table 5.8: Connection data

Ferrules without insulating collar (according to DIN 46228-1)	Cross section: 0.22 mm ² to 1.5 mm ² Length: 5 mm to 10 mm
---	---

Table 5.9: Specifications for ferrules

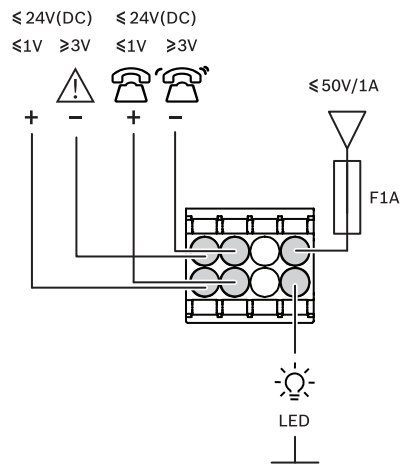

Figure 5.15: Connection diagram

6 Mechanical installation of Central Equipment

6.1 Audio processor and powering switch and Powering switch

The Audio processor and powering switch is used:

- to control system audio signals,
- to route audio signals to/from devices,
- to supply power to devices,
- as an Ethernet switch to connect the PC and the participant and interpreting DICENTIS devices.

The Powering switch is used to:

- supply power to devices.

Scope of delivery

The Audio processor and powering switch and Powering switch are shipped with the following parts:

- 1x Mains power cord.
- 1x Safety instructions.
- 1x Set of 19 inch mounting brackets.
- 4x bottom feet.
- 1x DVD containing manuals (only with Audio processor and powering switch).

Front view

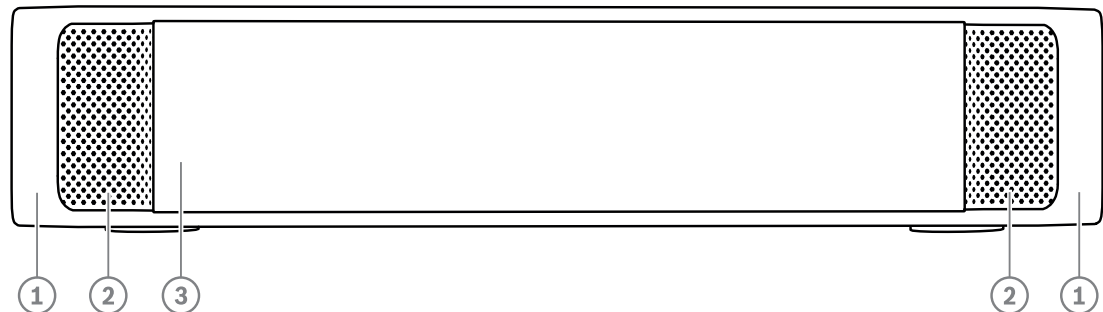

Figure 6.1: Audio processor and powering switch / Powering switch

Item	Description
1	19" mounting brackets.
2	Ventilation inlet.
3	<p>Indication LED:</p> <p>Off: Switched off.</p> <p>Green: Switched on.</p> <p>Amber: Standby.</p> <p>Blinking: Services on the server PC are not running.</p> <p>Alternating green amber: When a software download is required.</p>

Rear view

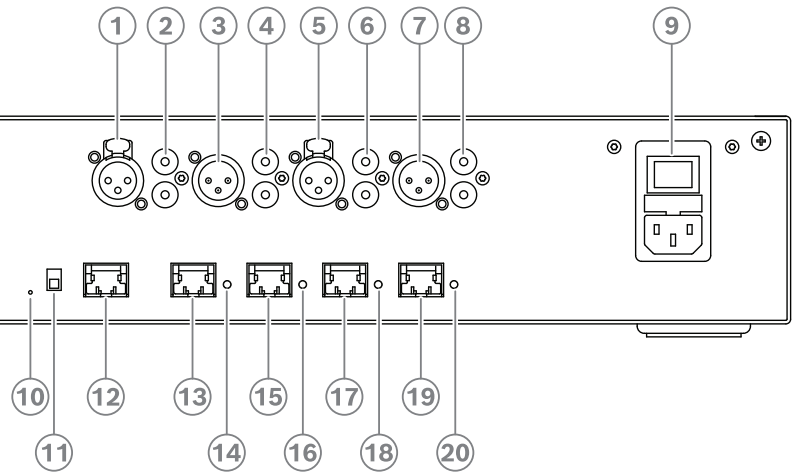

Figure 6.2: Audio processor and powering switch

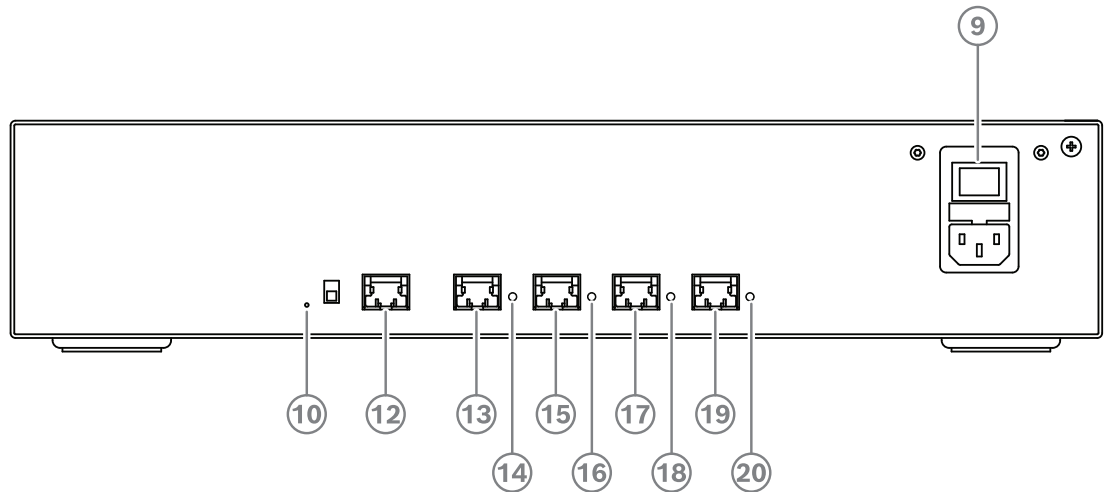

Figure 6.3: Powering switch

Item	Description
1, 5	XLR line inputs 1 and 2.
2, 6	RCA line inputs 1 and 2.
3, 7	XLR line outputs 1 and 2.
4, 8	RCA line outputs 1 and 2.
9	Mains inlet, mains switch and fuse holder.
10	Reset button.
11	Ground switch (grounded or floating).
12	Socket 1 without power.
13	Socket 2 low power.
15, 17, 19	Socket 3, 4, 5 high power.

Item	Description
14, 16, 18, 20	Overload LED for sockets 2-5: Green: Power OK. Red: Overload. Remove cable and wait a few seconds for the system to reset the overload.

How to install

- ▶ Install the Audio processor and powering switch or Powering switch in a 19 inch device rack system or on a flat surface. Two 19 inch mounting brackets and four bottom feet are supplied with the Audio processor and powering switch and Powering switch. Refer to the following illustration.
- ▶ Connect all required cabling.
- ▶ Connect the mains supply.

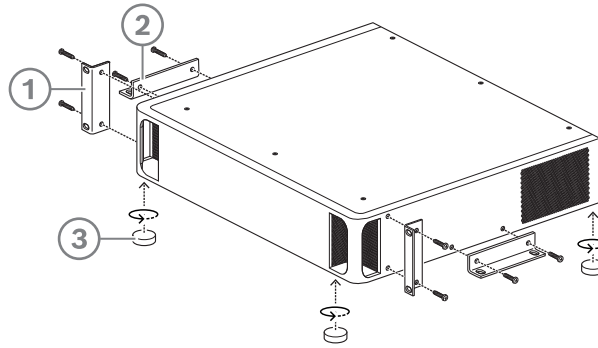

Figure 6.4: 19 inch rack, flat surface and feet mounting

Item	Description
1	19 inch rack mounting (bracket)
2	Flat surface mounting (bracket)
3	Feet mounting



Notice!

The unit extends 30 mm in front of the 19” mounting brackets when installed in a 19” rack system.



Caution!

Do not obstruct the airflow vents on the front side and rear left and right sides.

6.2 System server

The DICENTIS System server is provided with pre-installed and configured Windows Server® for Embedded Systems - Telecommunications (16 Core), pre-installed DICENTIS Conference System software, and pre-configured DHCP server.

Note: please refer to the datasheet for the technical specifications.



Notice!



The DICENTIS System server contains a printed Microsoft End User License Agreement (EULA) that needs to be handed over to the End User.

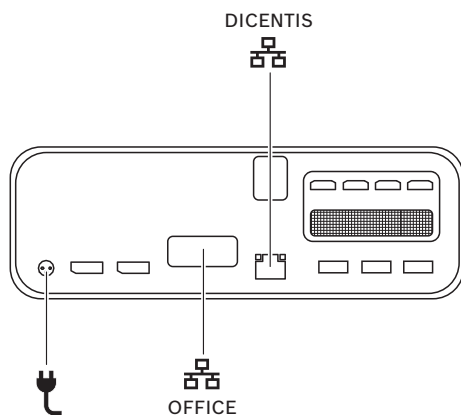

Notice!

Mounting accessories are available from HP.



<p>DICENTIS</p> 	<p>Network port to connect the DICENTIS system.</p>
<p>OFFICE</p> 	<p>Network port to connect to a network other than the DICENTIS network.</p>
	<p>Power supply input.</p>

How to install

The DICENTIS System can be mounted under a desk, behind a display or in a rack.

To install the system server:

1. Connect the DICENTIS System to the DICENTIS system (i.e. DCNM-(A)PS2 or network switch) using a CAT-5E cable.
2. Connect the OFFICE network port to non-DICENTIS devices, such as cameras and SDI switches, room control systems or the office network.
3. Connect the mains supply.
4. Power on the system by pressing the power button.

Note: you can power off the system by pressing the power button for 4 seconds.

6.3 Dante gateway

OMNEO offers a professional-grade media networking solution that uses Dante™ as one of the possible media transmission protocols while providing additional features such as encryption. The OMN-DANTEGTW makes it easier for system designers to take advantage of these unique OMNEO features and manage their network configurations with additional multicast management and RSTP network topologies when combining OMNEO and standard Dante™ networks.

The OMN-DANTEGTW features:

Audio streams	64 in both directions
Sampling rate	48 kHz
Audio	24-bit
Audio encryption	16 streams in both directions

Mechanical	
Mounting	Mounted in a 19" rack
Dimensions (WxHxD) with mounting brackets Rack unit	483 mm x 44 mm x 400 mm (19 in x 1.75 in x 15.7 in.) 19 in., 1U
Case: Material Color	Steel RAL9017
Frame: Material Color	Zamak RAL9022HR
Weight	6.14 kg



Notice!

In a large system (with over 450 DICENTIS nodes), the OMN-DANTEGTW must be installed in the VLAN where the OMN-ARNI-E is available. In large systems, the OMN-DANTEGTW becomes the clock master and the OMN-ARNI-E can distribute it to the other VLANs / OMN-ARNI-S devices.

Rear panel

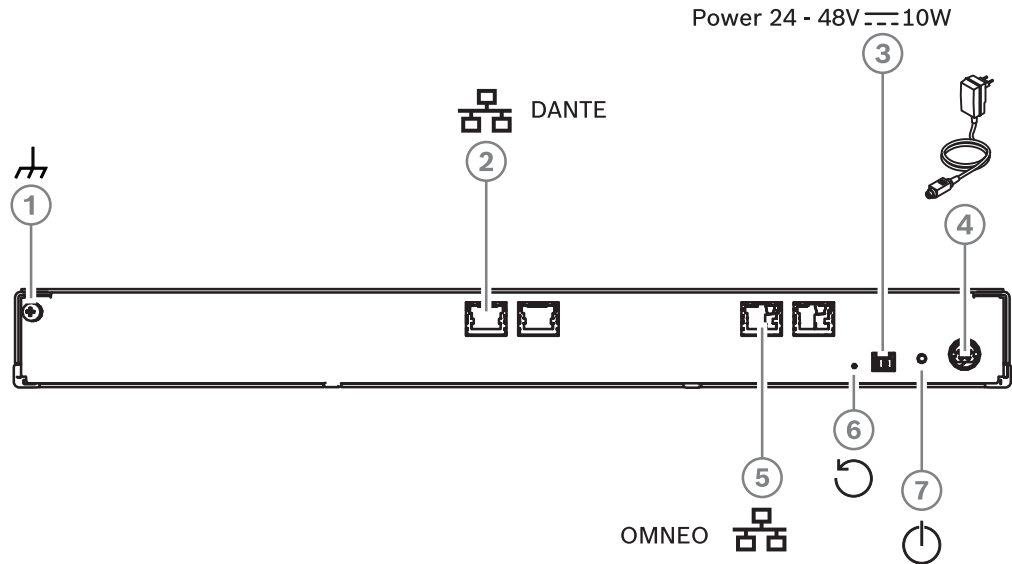

Figure 6.5: OMN-DANTEGTW rear panel description

Item	Description
1	Ground connection.
2	Dante connection.
3	Power input 24-48 VDC 10 W (optional).
4	Power supply.
5	OMNEO connection.
6	Press and hold for over 10 seconds to reset to factory defaults.
7	Power LED.

Network port LED color	Description
Green	1 Gbit/s connection. Blinking indicates activity (traffic). Preferred connection
Orange	100 Mbit/s connection. Blinking indicates activity (traffic). Supported connection, not preferred
Off	No connection or 10 Mbit/s connection. Connection not supported

Front panel

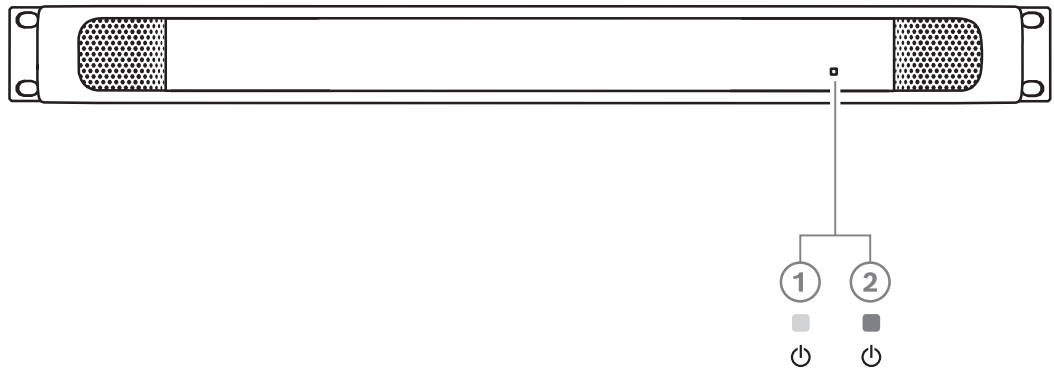

Figure 6.6: OMN-DANTEGTW front panel description

Power LED state	Description	How to solve
Steady yellow (1)	The Dante gateway is still booting/connecting to the network	<ul style="list-style-type: none"> - Wait until fully booted, this takes about 30 seconds. - Make sure at least one of the network connectors at the Dante™ side has a link indication.
Blinking yellow (1)	The Dante gateway is experiencing a problem	<ul style="list-style-type: none"> - Connect the OMNEO side to an Ethernet network. The Ethernet connector must show the link indication. - If there are multiple Dante gateway's in the same OMNEO network, make sure the Dante™ side of these gateways is also in the same Dante™ network. - Make sure there is no network connection between the Dante™ and the OMNEO side. This is never allowed. - If there is only a single Dante gateway, use the Dante controller to set the Dante gateway as preferred clock master. - If these tips do not solve the problem, the device is broken and needs to be exchanged.
Steady green (2)	The device is fully operational and discoverable at both the Dante™ and the OMNEO sides	N/A

Power LED state	Description	How to solve
Alternating yellow/green	The AES70 identify function is active	– Disable the Identify function (e.g. via Docent). Rebooting the device will also cancel this function.
OFF	The device has no power	– Check the Ethernet connector LEDs: <ul style="list-style-type: none"> – If they are lighted, power-cycle the Dante gateway to restart it. – If the Ethernet LEDs are off, the power supply is probably broken and needs to be exchanged.

How to install

To install the Dante gateway:

- ▶ Connect the Dante network port in the OMN-DANTEGTW to a network port in the Dante network.
- ▶ Connect the OMNEO network port in the OMN-DANTEGTW to the OMNEO network.
- ▶ Connect the mains supply.

7 Mechanical installation of Contribution Devices

The DICENTIS (tabletop and flush-mounted) devices are used to:

- participate in a meeting or conference.
- monitor and control a meeting or conference (chairperson use, depending on the configuration).

7.1 Connecting DICENTIS devices

The DICENTIS Conference System can be quickly and easily configured as a daisy-chain configuration or as a star configuration:

- **Daisy-chain configuration:** Uses dedicated cabling, consisting of CAT-5e cables including two additional power conductors (see *Typical system setup*, page 10).
- **Star configuration:** Each DICENTIS device is connected with an individual standard CAT-5e cable. An Ethernet switch is also required for providing Power over Ethernet (PoE).



Notice!

When Power over Ethernet is used, DICENTIS devices cannot be daisy-chained.

The star configuration makes use of connectors underneath the devices, ensuring for a neat, tidy system installation, especially advantageous for TV coverage.

To connect the system network cables to the DICENTIS devices (refer to the following figure):

1. Insert the system network cable/connector (2).
2. Lead the system network cable through the cable guides (3).

Installing DICENTIS devices

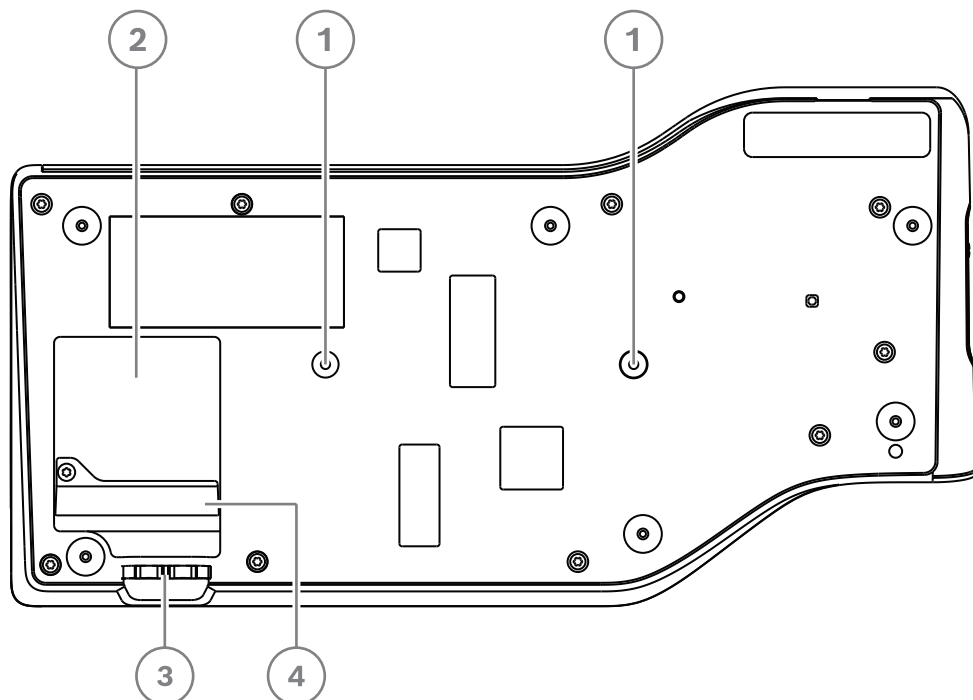

Figure 7.1: Bottom view discussion DICENTIS devices (DCNM-MMD / DCNM-MMD2)

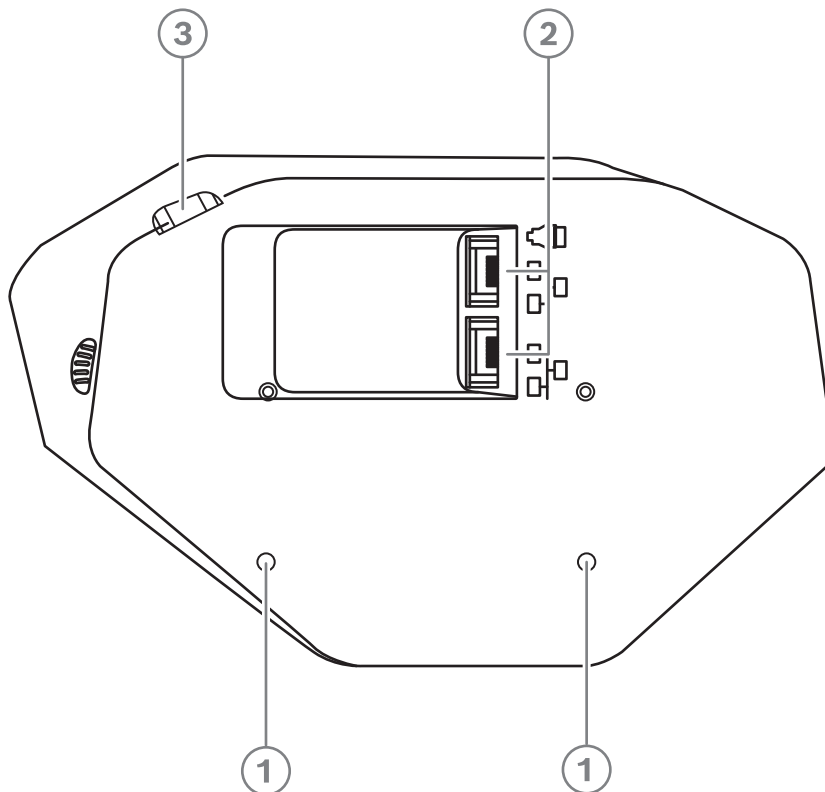

Figure 7.2: Bottom view DICENTIS devices (DCNM-D / DCNM-DVT / DCNM-DSL / DCNM-DE)

Item	Description
1	Screw insert for fixed installation.
2	2x RJ45 connection input/output for system power cable.
3	Cable guides.
4	USB connector, for future use (DCNM-MMD / DCNM-MMD2 only).

Refer to

- *Typical system setup, page 10*

7.2 DICENTIS tabletop devices

DCNM-MMD / DCNM-MMD2

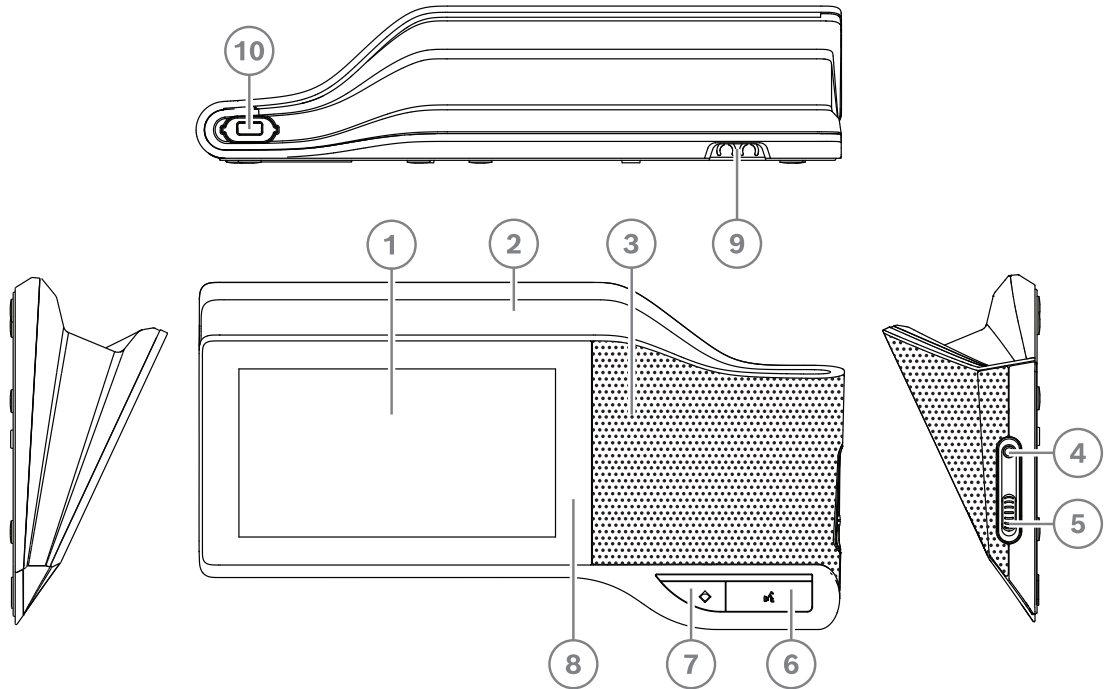

Figure 7.3: Front, top, rear and side views

Item	Description
1	7" capacitive touch screen.
2	LED strip.
3	Two-way loudspeaker.
4	3.5 mm stereo jack for headphone or headset with integrated microphone.
5	Headphone volume control.
6	Microphone request button.
7	Chairperson priority or microphone mute button.
8	Near Field Communication (NFC) reader (DCNM-MMD2 only).
9	Cable guides.
10	Microphone input connector.

- DCNM-MMD2 is compliant with the Radio Equipment Directive (RED) 2014/53/EU.
- Operating frequency is 13.56 MHz. Maximum field strength is 8.05 dBµA/m @ 3m.



Warning!

This equipment is compliant with Class A of CISPR 32. In a residential environment this equipment may cause radio interference. This equipment is intended for environment Class A.

DCNM-D / DCNM-DVT / DCNM-DSL / DCNM-DE

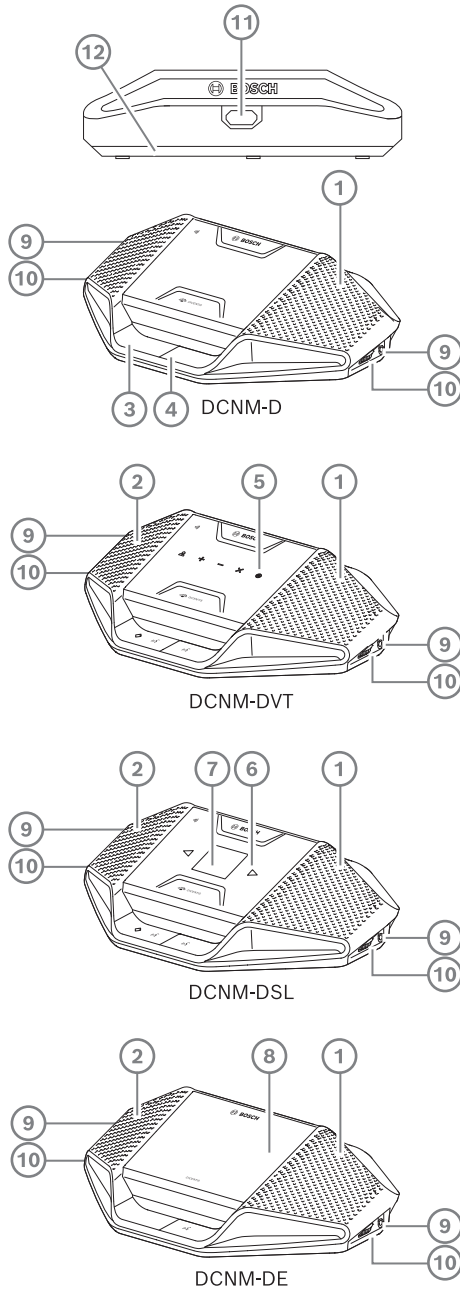

Figure 7.4: Front, top, rear and side views

Item	Description
1	Two-way loudspeaker.
2	Near Field Communication (NFC) reader.
3	Chairperson priority button, microphone mute button, or microphone request button for second participant.
4	Microphone request button.
5	Voting buttons.

Item	Description
6	Language selection buttons.
7	Language display.
8	4.3" capacitive touch screen.
9	3.5 mm stereo jack for headphone.
10	Headphone volume control.
11	Microphone input connector.
12	Cable guides.

- DCNM-DE, DCNM-DVT and DCNM-DSL are compliant with the Radio Equipment Directive (RED) 2014/53/EU.
- Operating frequency is 13.56 MHz. Maximum field strength is -8.4 dB μ A/m @ 10m.

Refer to

- *DICENTIS System cable assemblies, page 38*
- *DCNM-CB250 System installation cable, page 41*

7.3 DICENTIS flush-mounted devices

The flush-mounted devices create individual participant positions. They are ideal for use in permanent installations, because they offer great flexibility due to their modular set-up. You can select different flush-mounted devices depending on the functionalities you require.

Snap mounting

Use the snap-mounting method to install flush-mounted devices in panels with a thickness of up to 2 mm. The snap-mounting method uses the click-to-fit mechanism of the flush-mounted devices. Simply ‘click’ the flush-mounted devices in the recess.

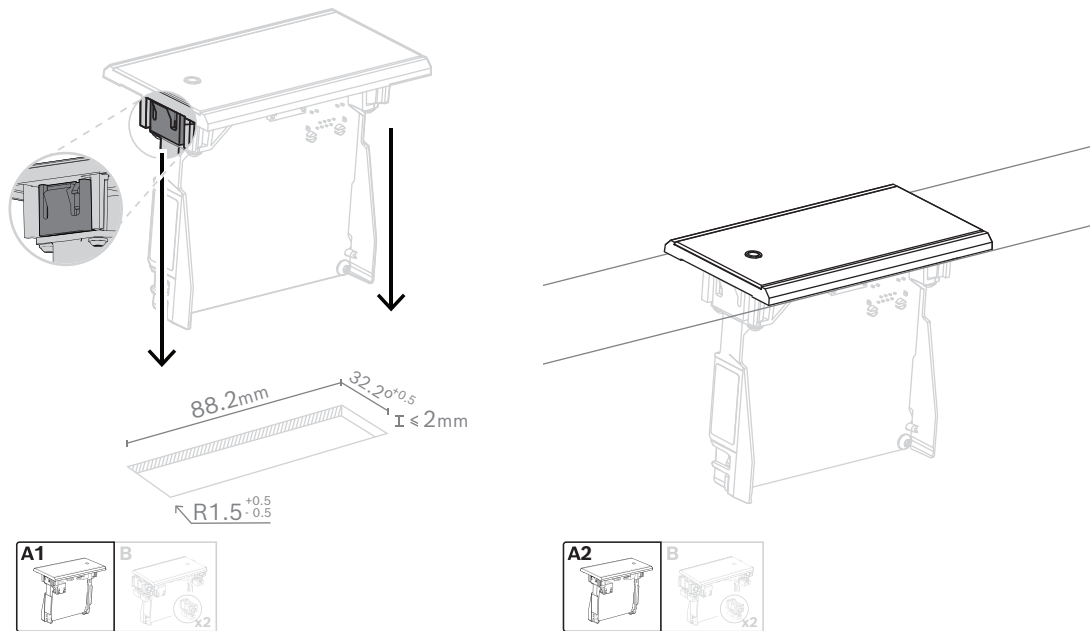

Click-to-fit mechanism

Note: Refer to the figure for the dimensions of a recess for the snap-mounting method.

The length (x) of a recess depends on the number-size factor (NSF) of the flush-mounted device that must be installed in the recess. To calculate the length of a recess:

- Get the number-size factor (NSF) of the flush-mounted device.
- Use the NSF to get the length (x) of the recess from the table.

Total NSF	x (mm)
1	38.2
2	88.2

Table 7.10: Lengths, snap-mounting method

Block-mounting

Use the block-mounting method to install the flush-mounted devices in surfaces with a thickness > 2 mm. The block-mounting method uses the DCNM-FEC Flush end caps, the DCN-FCOUP Couple Pieces and the DCNM-FPT Flush positioning tools.

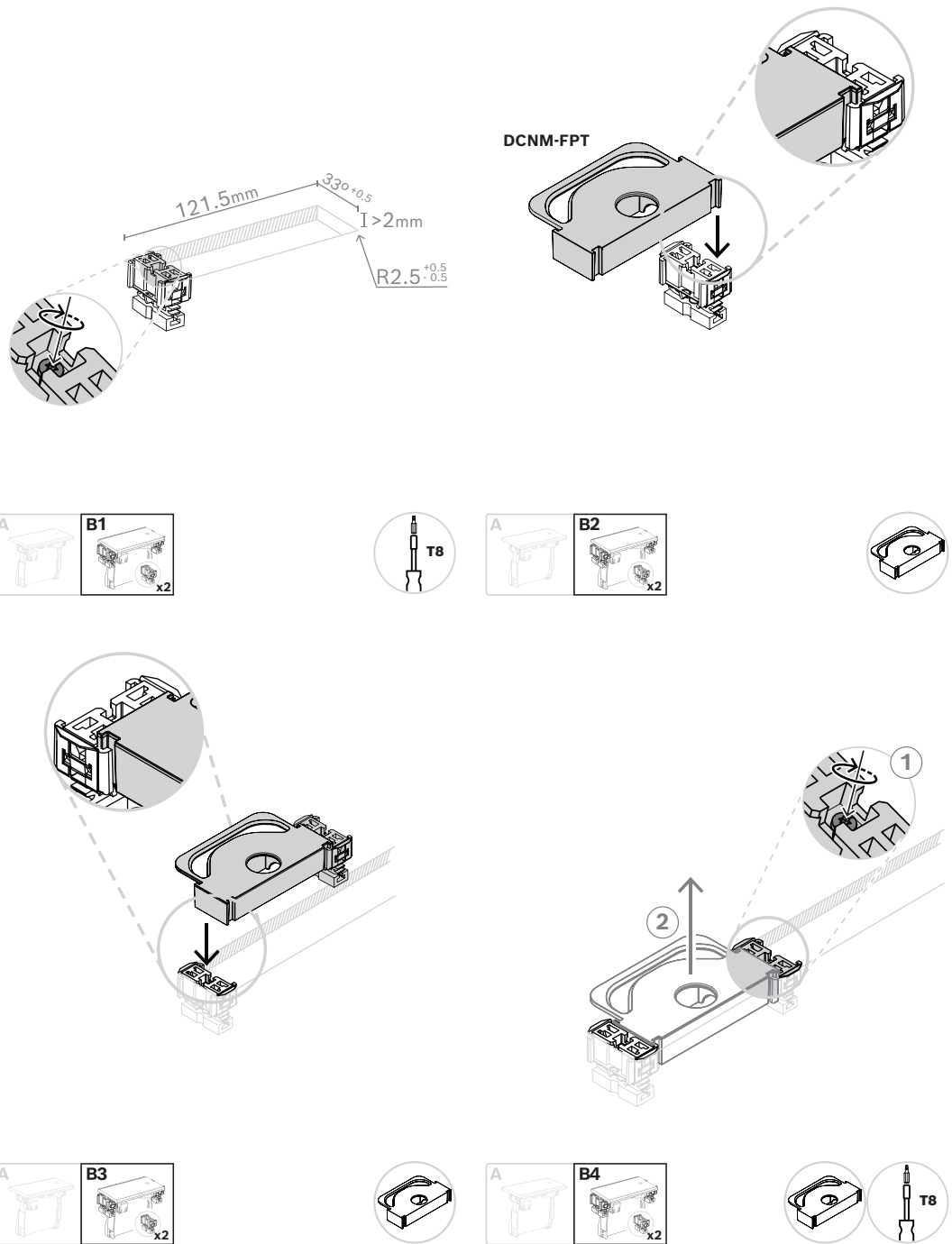

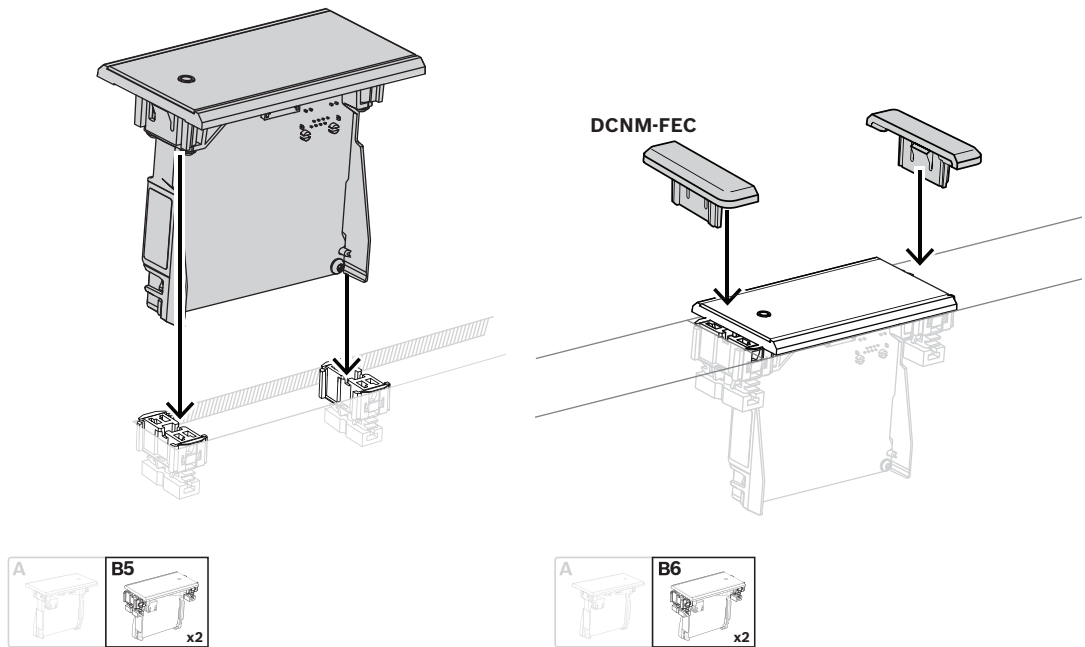

Block mounting method

Note: Refer to the figure for the dimensions of a recess for the block-mounting method.

The length (x) of a recess depends on the total number-size factor (NSF) of the flush-mounted devices that must be installed in the recess. To calculate the length of a recess:

1. For each flush-mounted device, get the number-size factor (NSF).
2. Add the NSF's of the flush-mounted devices to get the total NSF.
3. Use the total NSF to get the length (x) of the recess from the table. The length includes the DCN-FCOUP couple pieces.



Notice!

Install DCNM-FEC Flush end caps on the couple pieces at the two ends of the recess.

Total NSF	x (mm)
1	71.5
2	121.5
3	171.5
4	221.5
5	271.5
6	321.5
7	371.5
8	421.5
9	471.5
10	521.5

Total NSF	x (mm)
11	571.5
12	621.5

Table 7.11: Lengths, block-mounting method

Number-size factor

The length of a recess depends on:

- The number of flush-mounted devices that are installed in the recess.
- The size of the flush-mounted devices that are installed in the recess.

To calculate the length of a recess, you must use the number-size factor (NSF, refer to the table) of the flush-mounted devices.

Flush-mounted device	NSF
DCNM-FMCP	1
DCNM-FMICB	1
DCNM-FPRIOB	1
DCNM-FVP	2
DCNM-FSLP	2
DCNM-FIDP	1
DCNM-FLSP	2
DCNM-FSL	2
DCNM-FBPS	1
DCNM-FBPW	2

Table 7.12: Number-size factors

Removing a flush-mounted device

To remove a flush-mounted device installed on a surface, use the DCNM-FET Flush extraction tools.

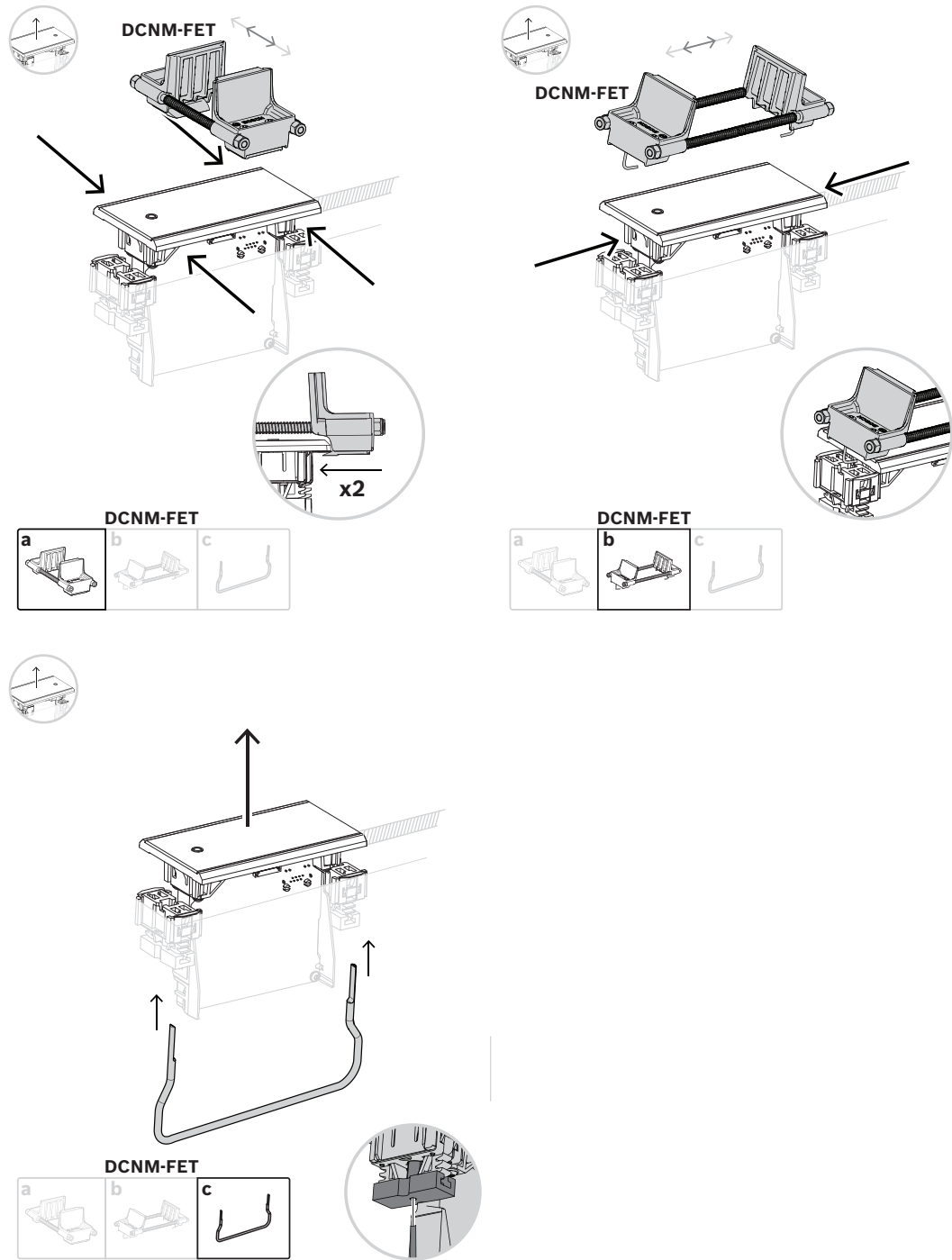

Removing a flush-mounted device

7.3.1 DCNM-FBD2 Flush base device

The flush base device is at the center of the various possible setups with the flush range. Besides the ports to connect the other flush products, it has two connectors for you to daisy-chain with the DICENTIS cables. Refer to *Connecting DICENTIS devices*, page 55.

Control connection

The flush base device has RJ12 connectors to power and control the button panels DCNM-FMICB or DCNM-FPRIOB. You can connect a maximum of four buttons, combining the DCNM-FMICB and the DCNM-FPRIOB.

Four cables with RJ12 plugs are supplied with the DCNM-FBD2. Use a 2 m cable to connect a panel to the DCNM-FBD2 and a 30 cm cable to loop through to the other panels.



Notice!

Use only one long cable per side to prevent the instability of the system due to drawing too much power from the DCNM-FBD2.

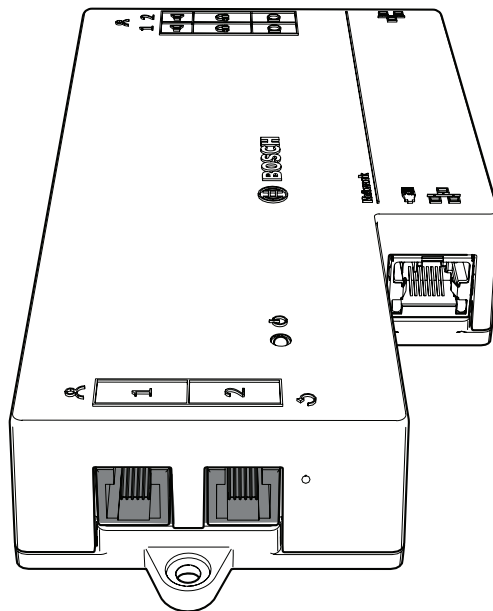

Notice!

The DCNM-FBD only supports the following panels:

- DCNM-FMCP
- DCNM-FMICB
- DCNM-FPRIOB
- DCNM-FLSP.

The DCNM-FBD2 supports the other panels.

Audio connection

The Flush base device has two rows of terminal block connectors for:

- Two loudspeaker outputs for loudspeaker connection with the DCNM-FLSP.
- Two microphone connectors for a balanced microphone connection with the DCNM-FMCP.

Pin	Signal	Function	Remark
1	Loudspeaker positive	Loudspeaker 🔊	8 Ω speaker, minimum 2 W.
2	Loudspeaker negative		
3	Headphone signal	Headphone/ headset 🎧	Headset not supported.
4	Headphone/headset plug detect		
5	Headphone GND		
6	Headset microphone signal		Pin not used.
7	Microphone GND	Microphone 🎤	Balanced, maximum input 5.5 dBV.
8	Microphone signal negative		
9	Microphone signal positive		

Table 7.13: Audio inputs/outputs

Refer to *DCNM-FMICB Flush microphone button panel*, page 69.

Fixating cables

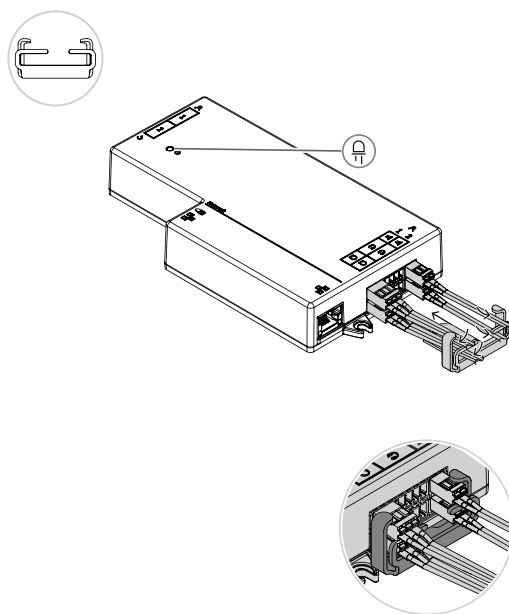

DCNM-FBD2 LED behavior

LED	Description
Off	The device is powered off.
Steady green	The device is ready or fully operational.
Blinking green	The device is not connected to DICENTIS services.
Steady orange	The device is booting.
Alternating between green and orange	The device needs to be updated or it has factory-software.

Panels per DCNM-FBD2

	DCNM-FMICB	DCNM-FPRIOB	DCNM-FIDP	DCNM-FVP	DCNM-FAI	DCNM-FSLP	DCNM-FLSP	DCNM-FMCP
Panels per side	2	2	2	2	2 ¹	1	1	1
Note	You can connect up to four of these panels on each side of the DCNM-FBD2.							
¹ You can connect two DCNM-FAI per side to provide two custom microphone buttons. Each side only has one audio input.								

DCNM-FMICB	Flush microphone button panel
DCNM-FPRIOB	Flush priority button panel
DCNM-FIDP	Flush identification panel
DCNM-FVP	Flush voting panel
DCNM-FAI	Flush audio interface
DCNM-FLSP	Flush loudspeaker panel
DCNM-FMCP	Flush microphone connection panel
DCNM-FSLP	Flush language selection panel

7.3.2

DCNM-FMCP Flush microphone connection panel

The flush microphone connection panel connects the pluggable microphones, DCNM-MICSLS and DCNM-MICSLL, to the flush base device. For this purpose, with the DCNM-FMCP comes a 2 m cable with a 3-pole terminal block.

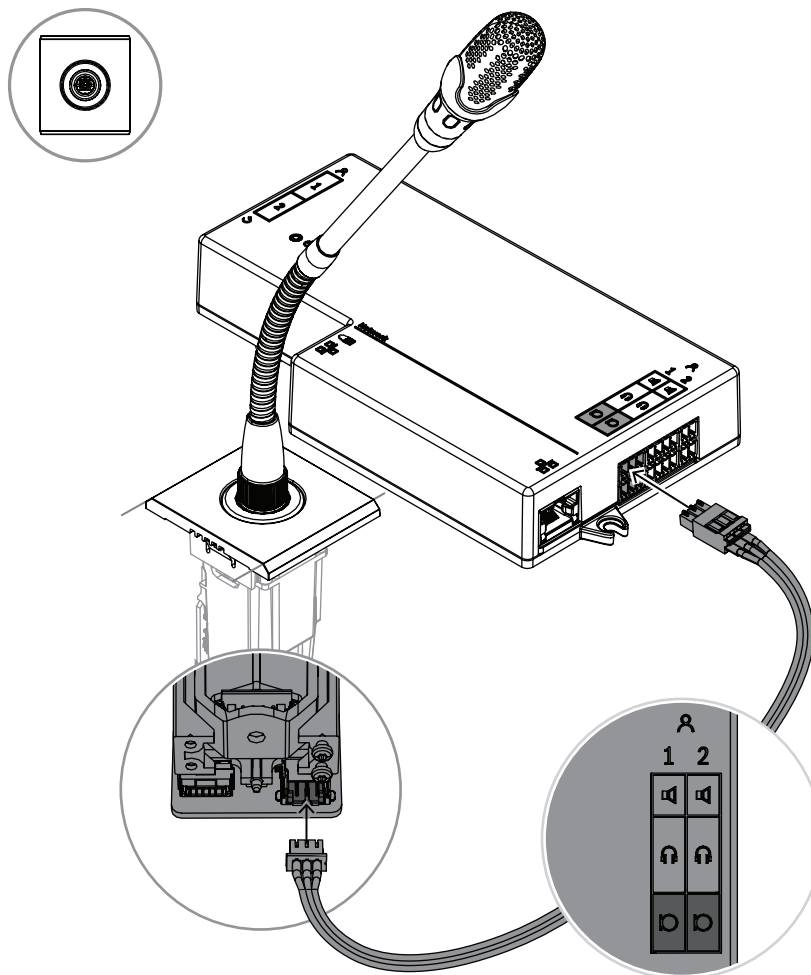
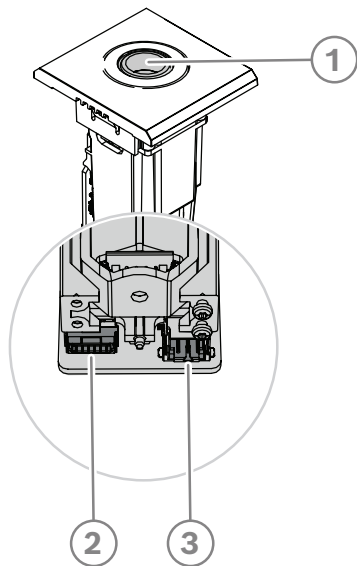

Figure 7.5: Connecting the DCNM-FMCP to the DCNM-FBD2

The DCNM-FMCP also connects to one of the button panels, DCNM-FMICB or DCNM-FPRIOB, which allows for control of the microphone's LED and for powering the microphone. For this connection, use the 30 cm cable that comes with the panel.



1	Connect the DCNM-FMCP to the DCNM-MICSL/DCNM-MICSL, as described in <i>DICENTIS Microphones</i> , page 94	2	Connect the DCNM-FMPC to the DCNM-FMICB/DCNM-FPRIOB/DCNM-FAI for power and control of the LEDs of the microphone and the DCNM-FMCP pre-amplifier
3	Connect the DCNM-FMCP to the DCNM-FBD2 for the audio		

7.3.3

DCNM-FMICB Flush microphone button panel

The flush microphone button panel has three connectors: two RJ12 connectors to connect to the DCNM-FBD2 or to another button panel, and one connector to power and control the microphone LEDs.

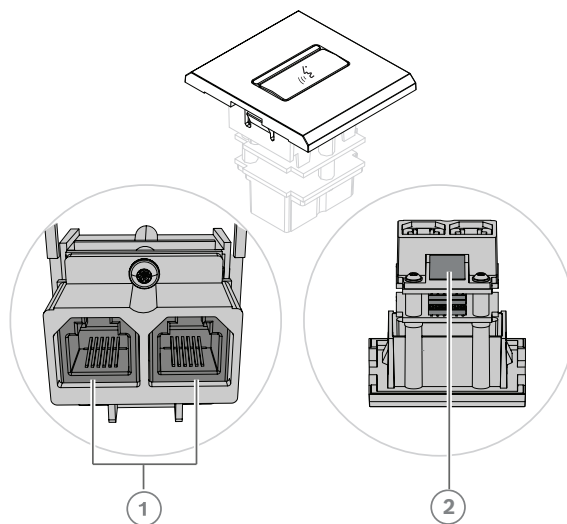

1	Connect the DCNM-FMICB to the DCNM-FBD2/other button panels	2	Connect the DCNM-FMICB to the DCNM-FMCP to enable the LEDs and pre-amplifier of the microphone connection panel
---	---	---	---

7.3.4

DCNM-FPRIOB Flush priority button panel

The flush priority button panel has three connectors: two RJ12 connectors to connect to the DCNM-FBD2 or to another button panel, and one connector to power and control the microphone LEDs. Use the 30 cm cable supplied with the DCNM-FPRIOB to loop through to the other panels.

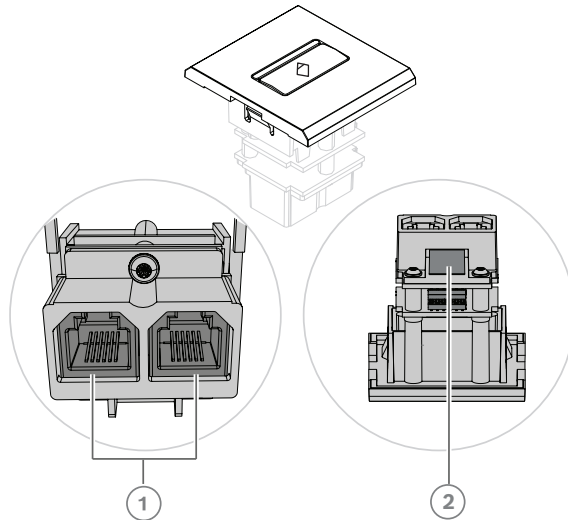

1	Connect the DCNM-FPRIOB to the DCNM-FBD2/other button panels	2*	Connect the DCNM-FPRIOB to the DCNM-FMCP to enable the LEDs and pre-amplifier of the microphone connection panel
---	--	----	--

*You only need to use this connector if:

- The seat does not have a DCNM-FMICB.
- Your setup has two microphones. DCNM-FMICB powers one and DCNM-FPRIOB powers the other.



Notice!

The DCNM-FPRIOB only functions as a priority button when the seat or participant has priority rights. If the seat or participant does not have priority rights, the DCNM-FPRIOB will be a mute or request-to-speak button, depending on the configuration in the discussion settings. The LEDs will be turned off.

7.3.5

DCNM-FLSP Flush loudspeaker panel

The flush loudspeaker comes with a fixed 2 m cable ended in a 2-pole terminal block to connect to the flush base device. The DCNM-FBD2 has two ports for loudspeakers, creating two participant seats. The DCNM-FLSP can be active at the same time as the microphone, making sure the speech intelligibility is excellent.

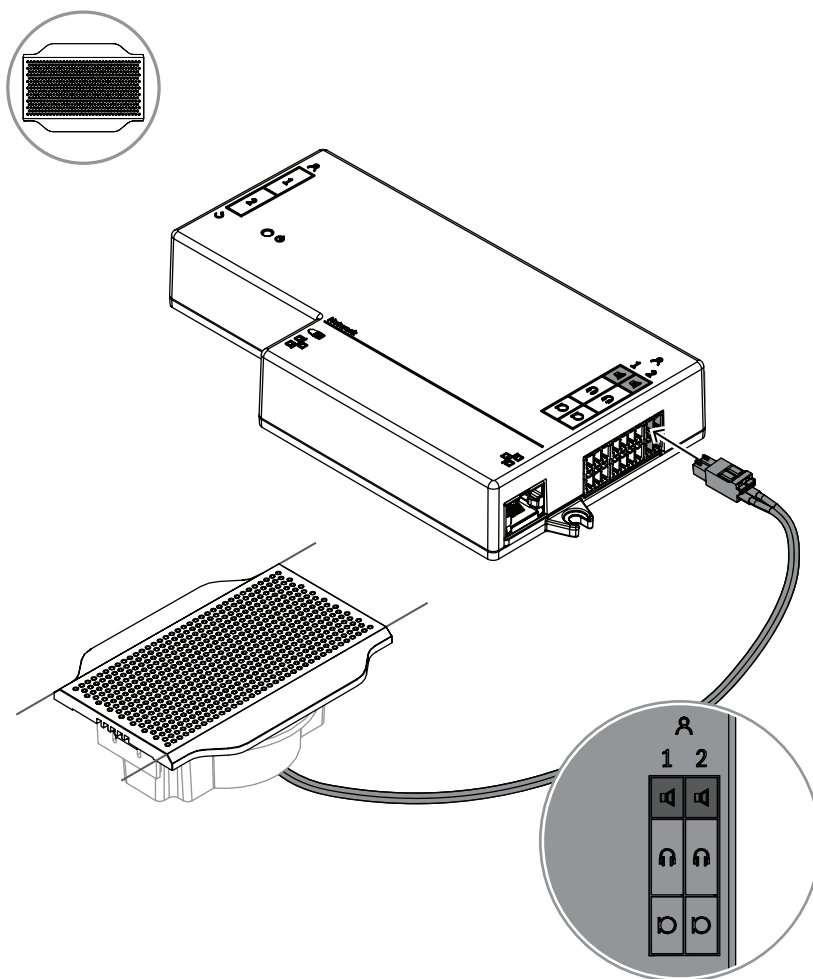
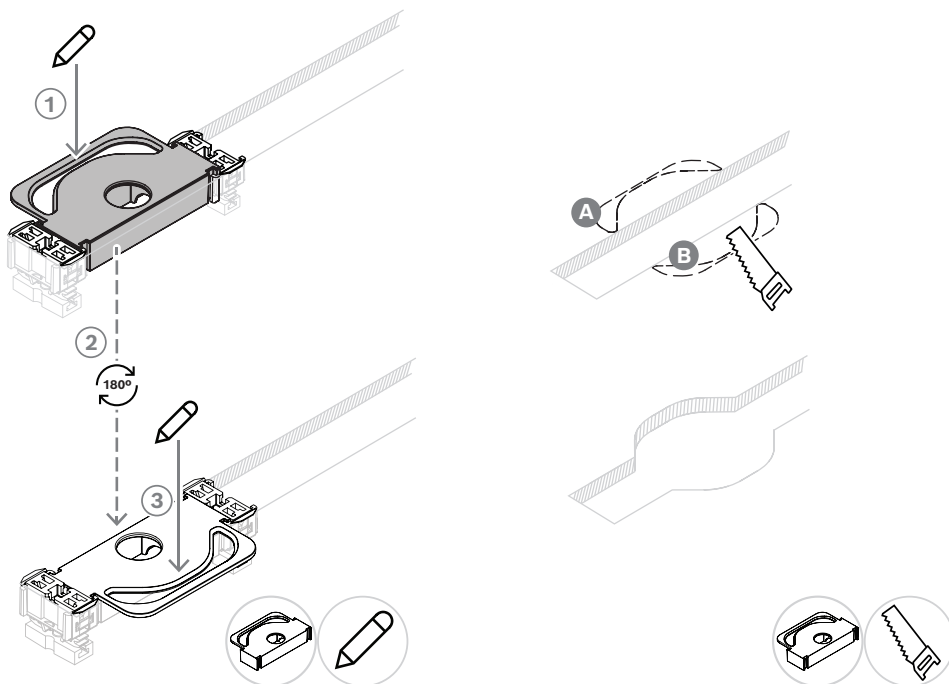

Figure 7.6: Connecting one DCNM-FLSP to the DCNM-FBD2

To use the DCNM-FPT to change a table cut for the DCNM-FLSP, position the 100 mm tool in the existing slot. Use it as a template to draw the lines by which you need to cut: the outside of the tool is the maximum cut, the inside of the tool is the minimum.



To use the DCNM-FPT to create a new table cut for the DCNM-FLSP, position the coupling pieces and use them to draw the lines by which you need to cut.

7.3.6

DCNM-FVP Flush voting panel

The flush voting panel comes with a 30 cm cable to connect, through RJ12, to the DCNM-FBD2 or to daisy-chain to the other panels.

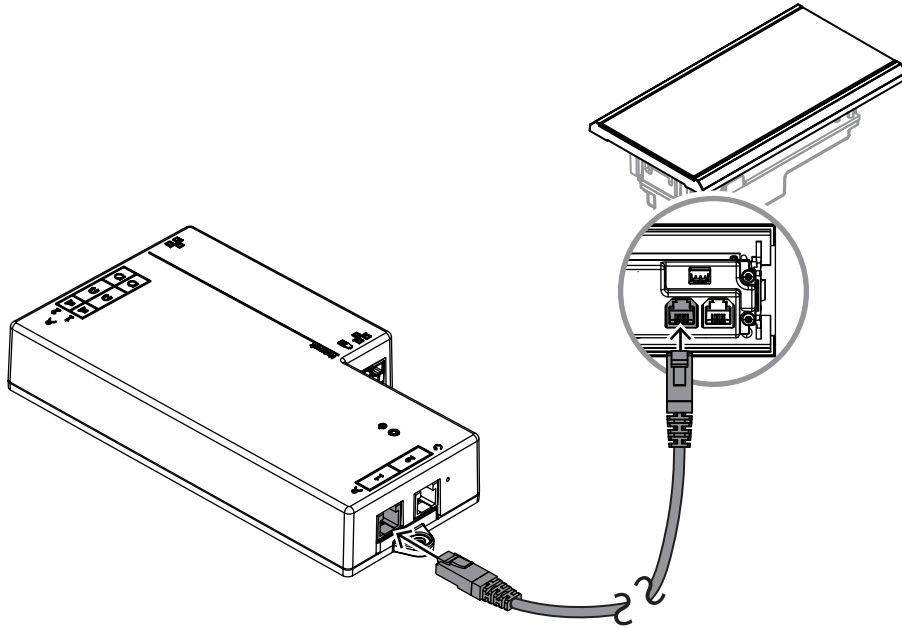
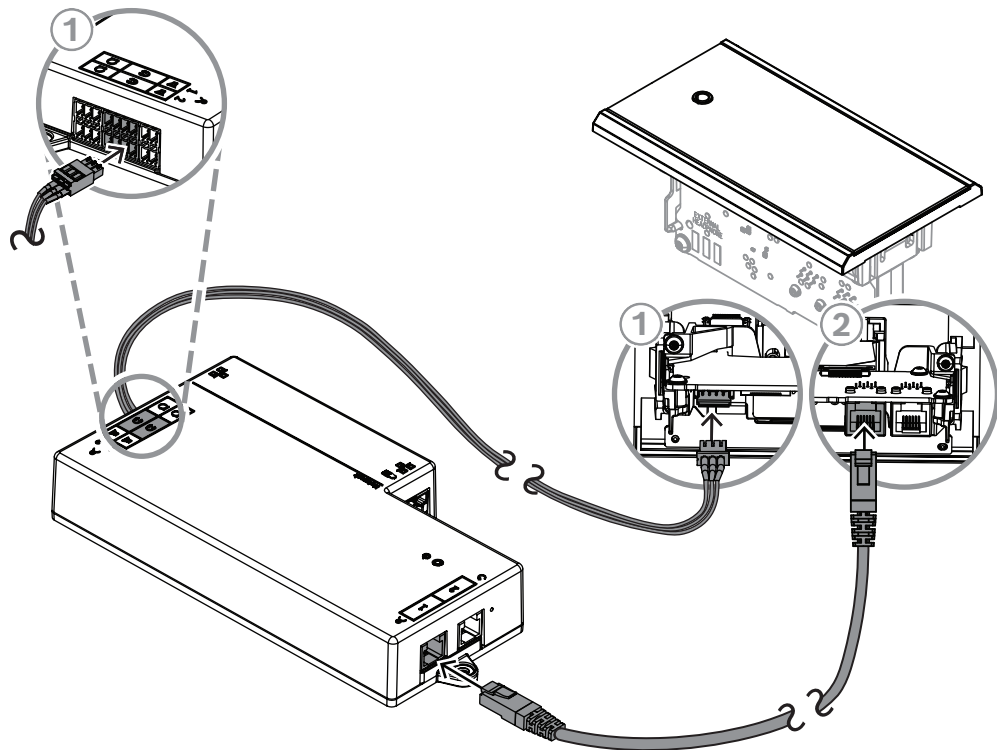

Figure 7.7: Connect the DCNM-FVP to the DCNM-FBD2 for control

7.3.7

DCNM-FSLP Flush language selection panel

The language selection panel comes with a 30 cm cable and with a headphone connection cable. Use the 30 cm cable to connect, through RJ12, to the DCNM-FBD2 or to daisy-chain to the other panels. Use the headphone connection cable to connect to the headphone connector of the DCNM-FBD2.



1 Connect the DCNM-FSLP to the DCNM-FBD2 or to the other panels for control

2 Connect the DCNM-FSLP to the DCNM-FBD2 for audio



Notice!

You can connect one language selection panel on each side of the DCNM-FBD2 to have a total of two in your setup.



Notice!

The loudspeakers will be muted if both headphones are used and each listens to a different channel.



Notice!

You can connect, for example, an AMP173977-3 socket to the language selector's external headphone plug.

External headphones socket

You can connect an external headphones socket to the language selector (e.g. a 3.5 mm headphones socket). The external headphones socket must be connected to a plug or to solder pads.

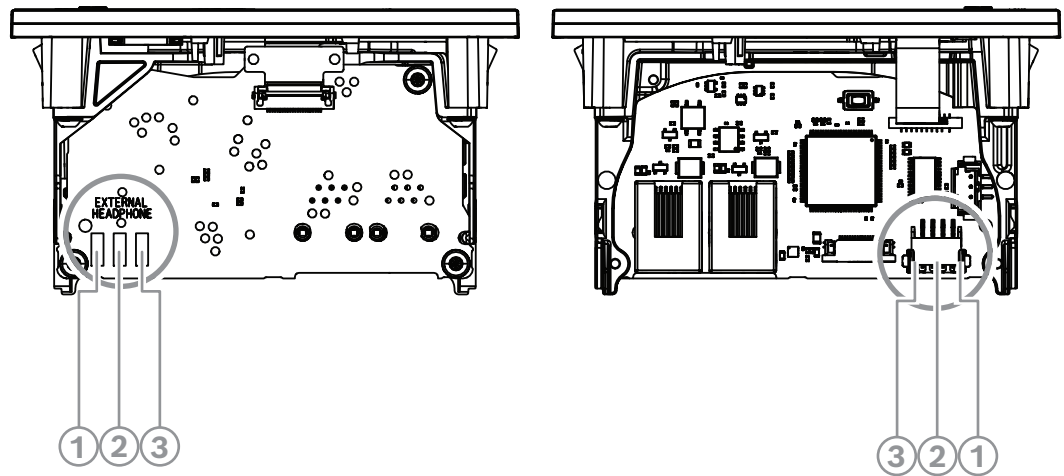

Figure 7.8: External headphones connection

The solder pads , external headphone connector, and built-in 3.5 mm socket are internally connected.

Plug (pin)	Solder pad	Signal
1	Left solder pad	Detect
2	Center solder pad	Signal
3	Right solder pad	GND

Table 7.14: External headphones connection



Notice!

You can connect, for example, an AMP173977-3 socket to the external headphones plug of the language selector.



Warning!

When using the external sockets of the DCNM-FSLP, make sure that all connections are electrically floating. In case any connections are part of an earth loop, unexpected system behavior can occur.



Warning!

To prevent the user from suffering an unpleasant ESD discharge while inserting the headphones into the connector, always use a headphone connector with a plastic front in combination with the external headphone connection.

External headphone connection

When using an external headphone connector, please install it according to the electrical diagram below (wiring and jack connector).

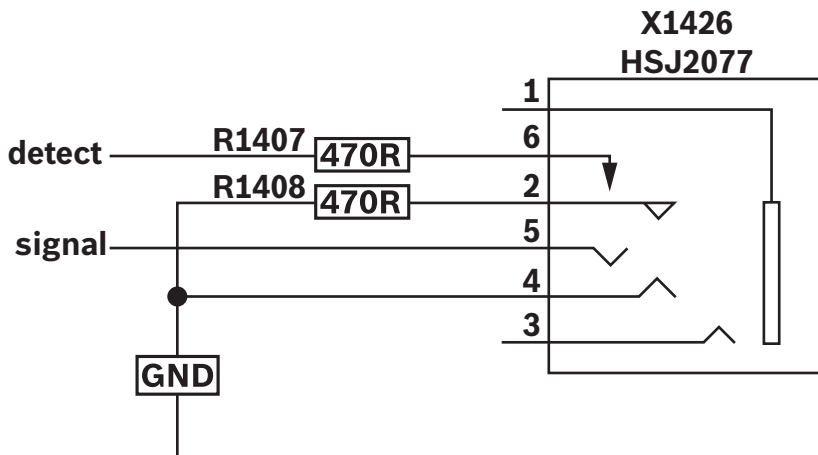

Figure 7.9: External headphone connector diagram

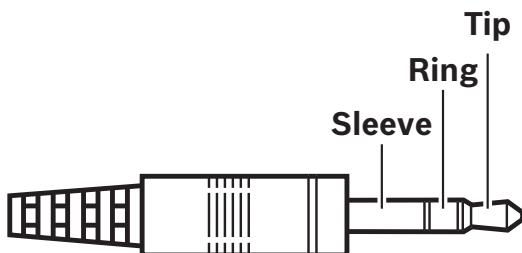

Figure 7.10: Headphone jack connection

	Tip	Ring	Sleeve
Normal	Audio R	Audio L	GND
DCNM-FSL	Signal	GND	<i>Not connected</i>

Table 7.15: Headphone jack connection

Notice!

The jack connector must include internal plug detection, which is used to enable the display. The display will not turn on if you use an incorrect connector (it should have a "jack inserted" switch). If you do not want to use this function, you must connect the detect signal to GND, so that the device thinks that a headphone is connected. Please note that this will cause the buttons' LEDs to be always on, which results in a shortened lifetime of the buttons' LEDs.



7.3.8

DCNM-FAI Flush audio interface

The flush audio interface connects to the flush hand held microphones to create participant seats and floor-standing positions. It also makes it easy to install a microphone that requires phantom power to the DICENTIS System flush-mounted setups.

You can use the DCNM-FAI for:

- Powering 1 or 2 DCNM-FCMP when you don't have a DCNM-FMICB or a DCNM-FRIOB.
- Connecting a DCNM-FHHC microphone to DICENTIS.

- Connecting a third party microphone or line level audio source to DICENTIS.
Note: In this setup, it can also provide phantom power.

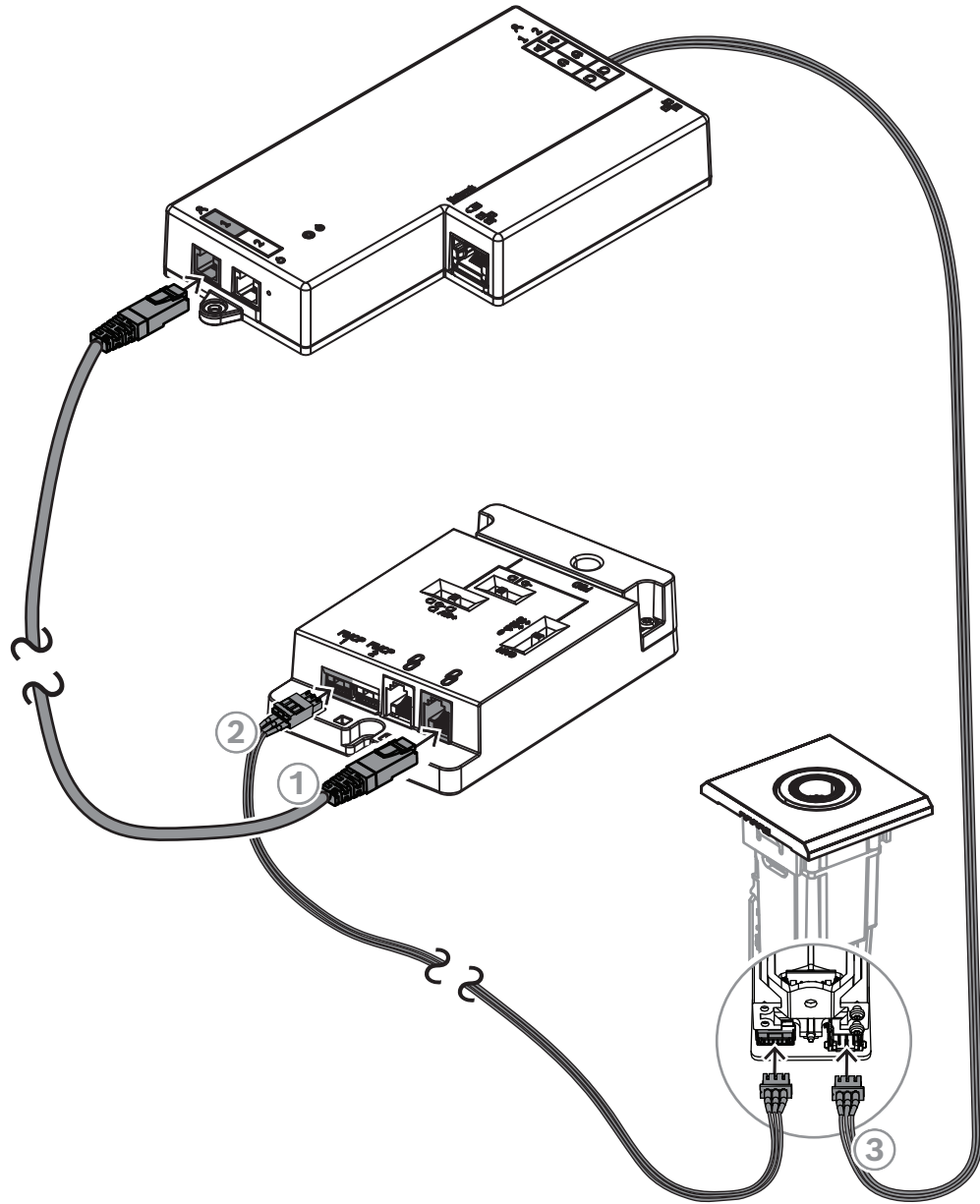

Figure 7.11: Connecting the DCNM-FMCP to the DCNM-FBD2 through the DCNM-FAI

1	Connect the DCNM-FAI to the DCNM-FBD2 for power and control	2	Connect the DCNM-FAI to the DCNM-FMCP to enable the LEDs and pre-amplifier of the microphone connection panel
3	Connect the DCNM-FMCP to the DCNM-FBD2 for the audio		

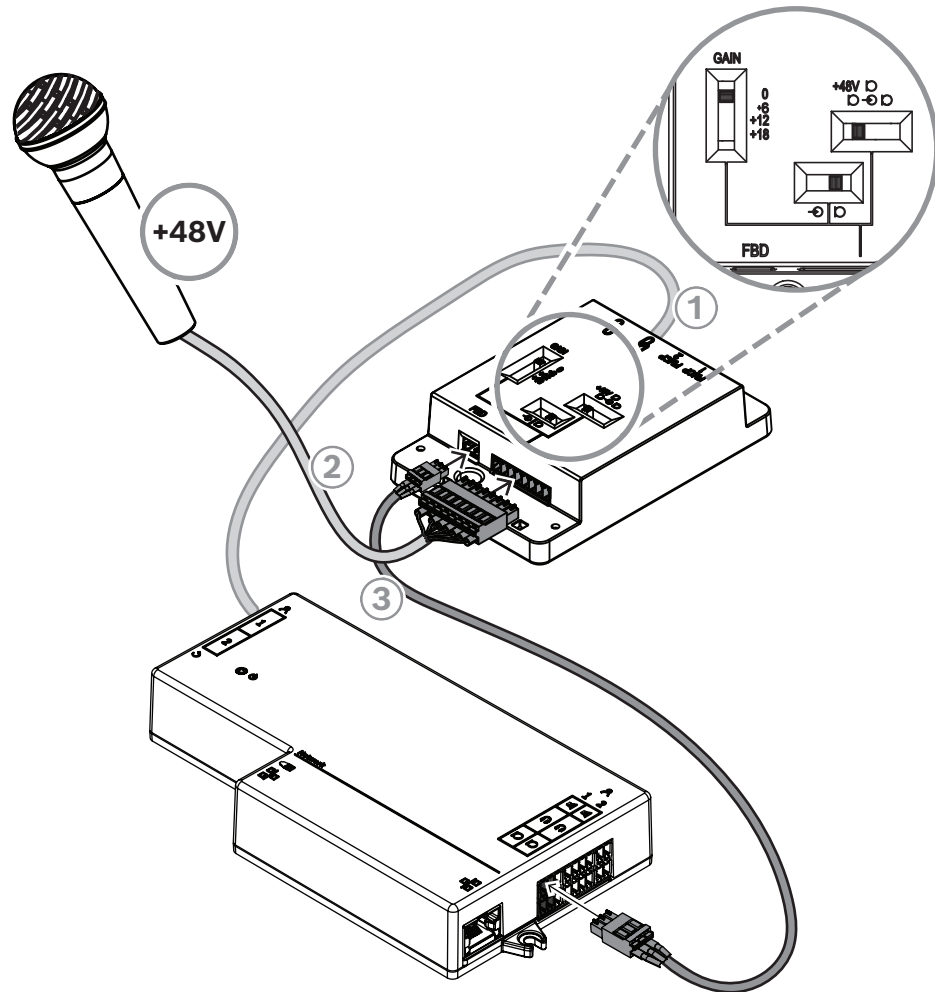

Figure 7.12: Connecting a phantom powered microphone to the DCNM-FBD2 through the DCNM-FAI

1	Connect the DCNM-FAI to the DCNM-FBD2 for power and control	2	Connect the DCNM-FAI to 3 rd party microphones and other audio equipment
3	Connect the DCNM-FAI to the DCNM-FBD2 for the audio		

To see how to connect the flush hand held microphones, refer to *DCNM-FHH / DCNM-FHHC Flush hand held microphones*, page 82.

Slide switches

The DCNM-FAI comes with the following preset from factory:

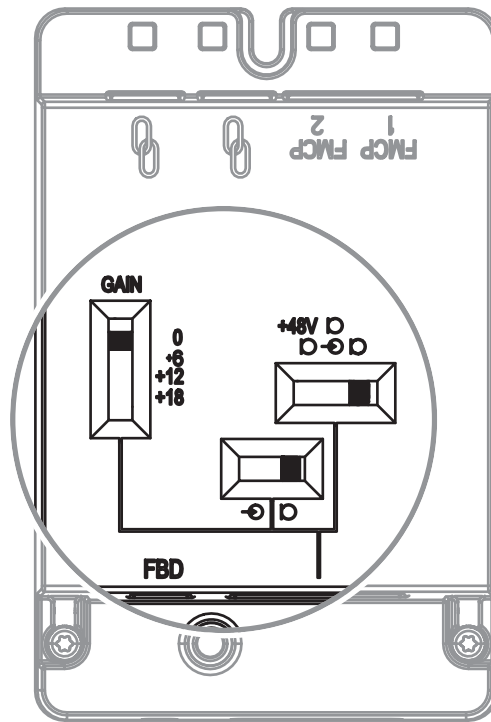

The DCNM-FAI has three slide switches to configure the audio settings:

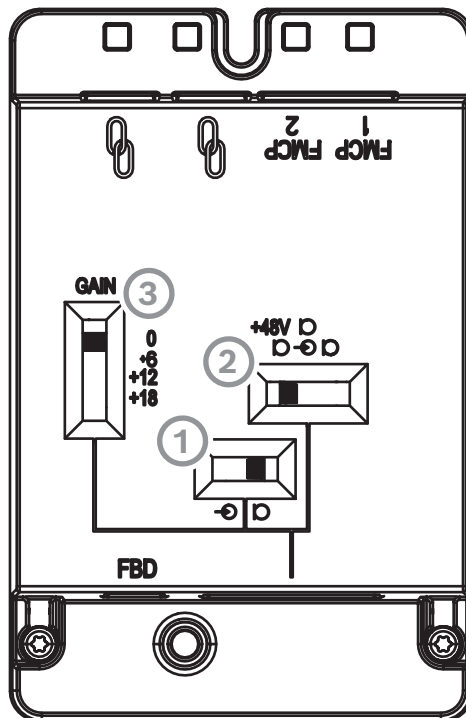

- The 1st switch selects Mic/Line levels. The input levels supported are:

Signal type	Nominal level	Maximum level
Line	-12 dBV	18 dBV
Microphone	-46 dBV	-16 dBV

Note: When the 2nd switch is set to no power, you can use the 1st switch to set the input to the Line level. In all other cases, the input level will be set to microphone level.

- The 2nd switch selects the power settings. The power settings supported are:

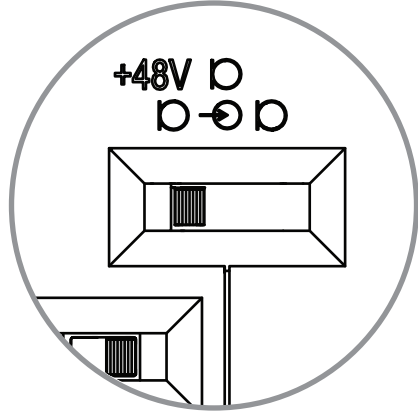
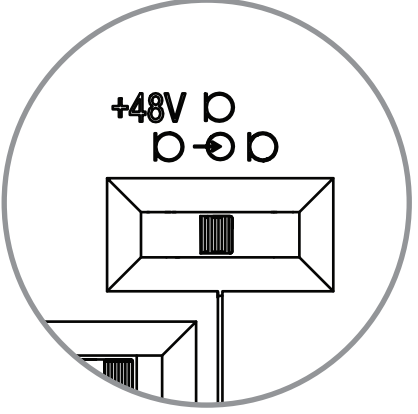
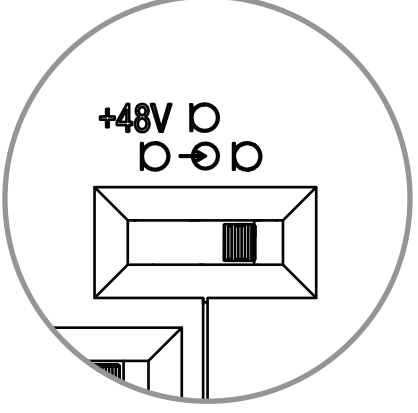
Phantom power of 48 V.	
No power on audio signal lines.	
Mic bias. This power setting does not support balanced signals.	

- The 3rd switch selects the gain settings between 0; 6; 12 and 18.

Note: When a microphone's output level is lower than the nominal level listed for the first switch, adjust the third switch. For example, if the nominal output of the microphone is -58 dB, set the switch to +12.

Pinout table

The DCNM-FAI also has an 8-pin connector with the signals for unbalanced and balanced audio, LED power for the microphone, and RTS button control.

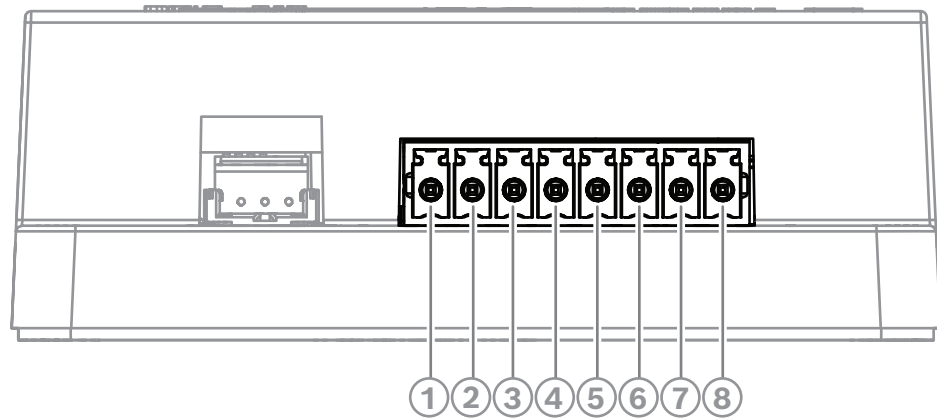

8-pin connector on FAI

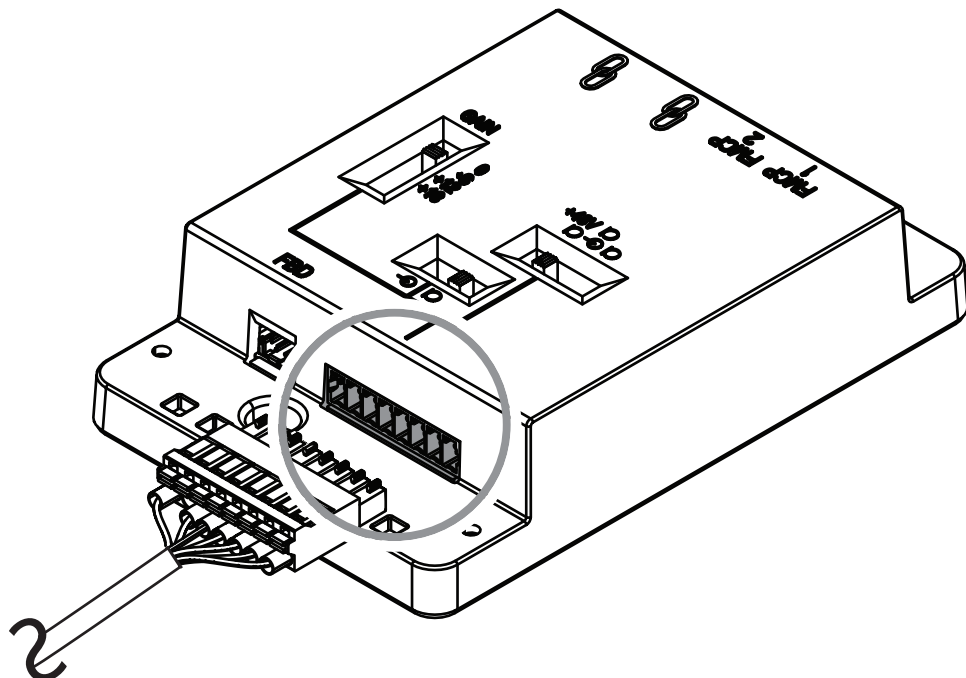

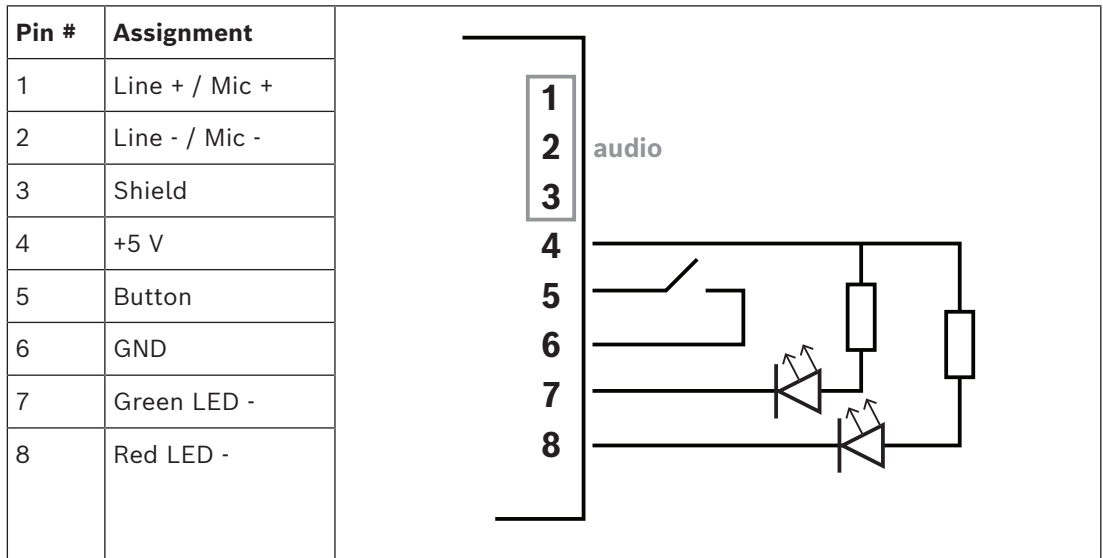

7.3.9

DCNM-FHH / DCNM-FHHC Flush hand held microphones

The Flush hand held microphones can be installed in participant seats without space for a tabletop or flush-mounted device. They can also create a floor-stand microphone position. Depending on your needs and preferences, choose the DCNM-FHH with a straight cable or the DCNM-FHHC with a coiled cable, both with 5 m.

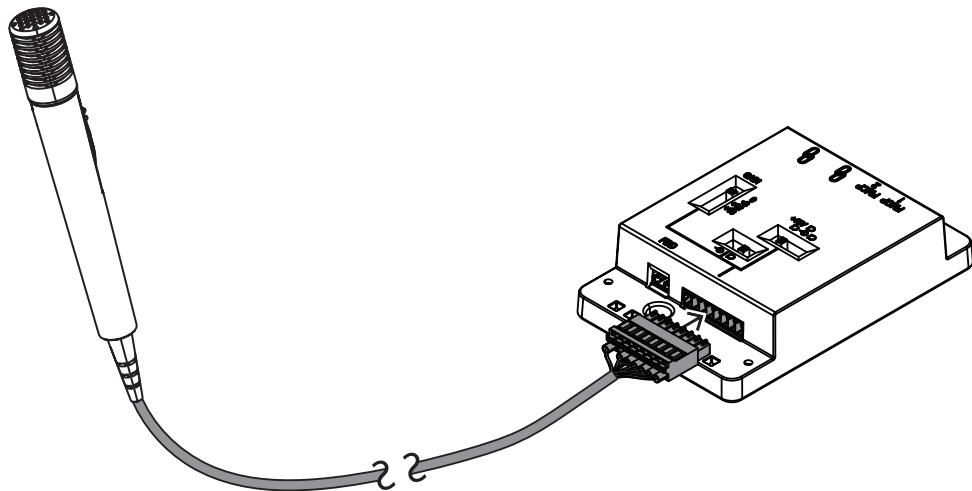

Figure 7.13: Connect the DCNM-FAI to the DCNM-FHH / DCNM-FHHC

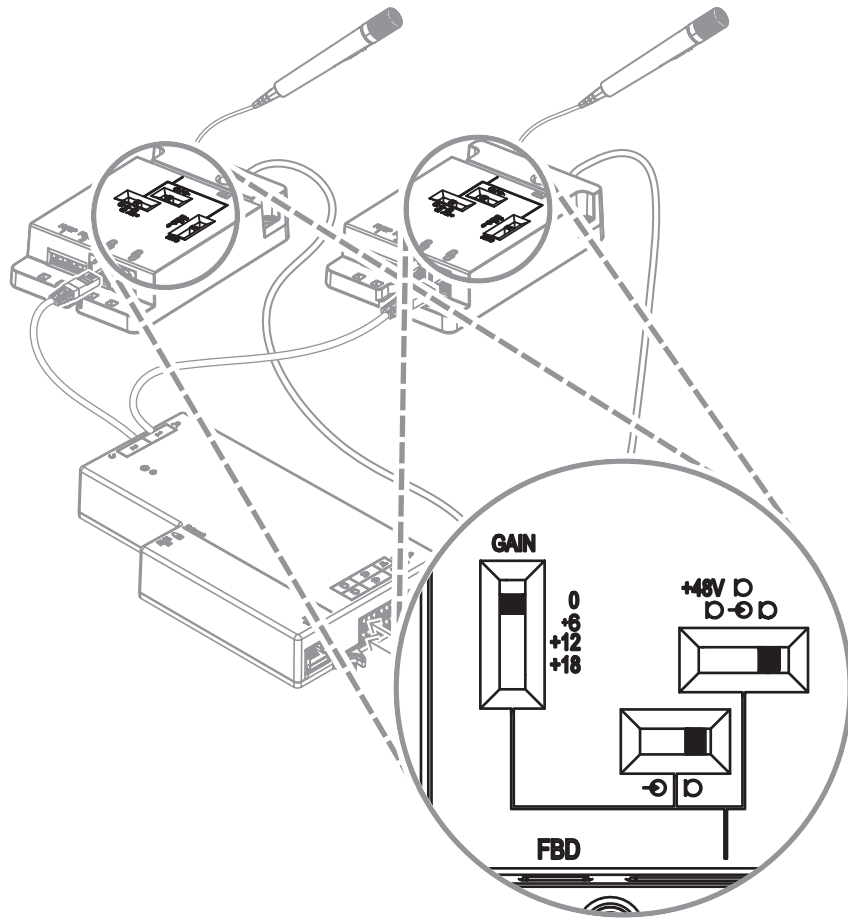

Figure 7.14: DCNM-FAI switch settings to connect the DCNM-FHH / DCNM-FHHC

7.3.10

DCNM-FIDP Flush identification panel

A flush identification panel is necessary for every seat that requires identification. The DCNM-FIDP comes with a 30 cm cable to connect, through RJ12, to the DCNM-FBD2 or to daisy-chain to the other panels. In dual use mode, four identification panels can be connected to the DCNM-FBD2.

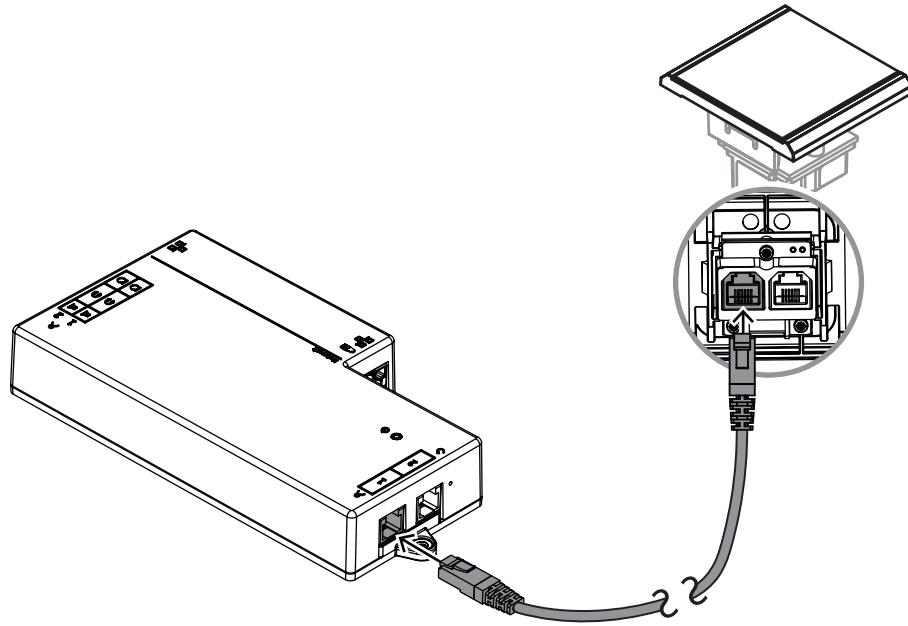

Figure 7.15: Connect the DCNM-FIDP to the DCNM-FBD2 for control

7.3.11

DCNM-FICH Flush ID card holder

NFC technology offers two methods of identification. The first is tapping the NFC as a way for a participant to quickly log in or out of a seat. Alternatively, NFC readers can read cards and keep users logged in as long as the card is detected by the reader.

The ID card holder makes sure that the ID card is correctly positioned next to the DCNM-FIDP for continuous and reliable identification. Mount it on the left or right of the DCNM-FIDP, at the end of the panels. The DCNM-FICH replaces the DCNM-FEC on that side.

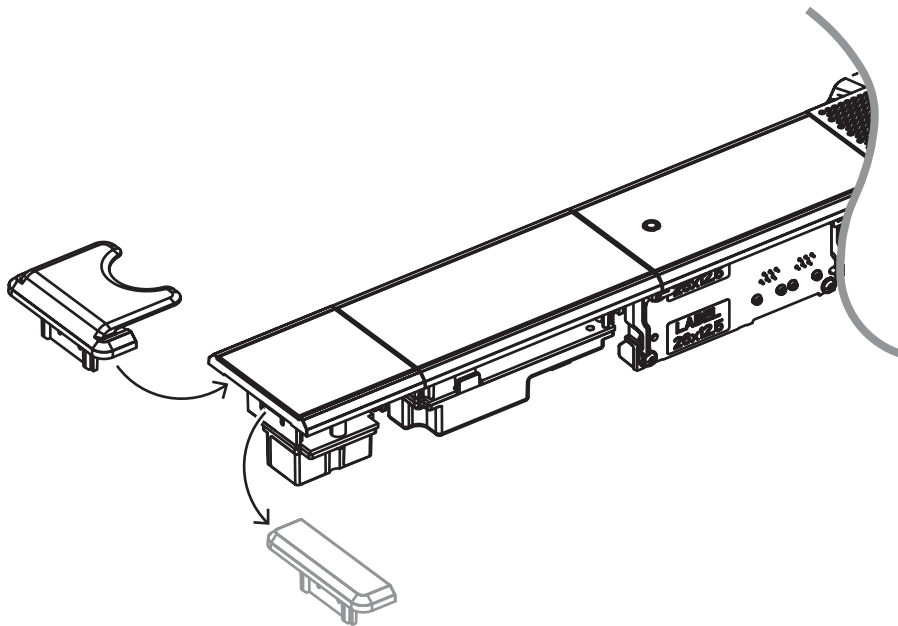

Figure 7.16: Replace the DCNM-FEC by the DCNM-FICH

7.3.12

Flush setups

The DCNM-FBD2 has:

- Two microphone inputs for the DCNM-FMCP or for the DCNM-FAI.
- Two control outputs to connect the
 - DCNM-FMICB
 - DCNM-FPRIOB
 - DCNM-FIDP
 - DCNM-FVP
 - DCNM-FSLP
 - DCNM-FAI.
- Two loudspeaker outputs for the DCNM-FLSP.

As such, you can build various setups depending on what you need:

- Two participant or chairperson seats, each with their own microphone, with:
 - Optional voting.
 - Optional language selection.
 - Optional participant identification.
- Four participant seats, with each pair sharing a microphone, with optional individual identification or voting for each of the four participants.
- A participant or chairperson seat with two microphones (rostrum) with:
 - Optional voting.
 - Optional language selection.
 - Optional participant identification.

Refer to the diagrams on how to set up a DICENTIS flush system.

Two participant or chairperson seats

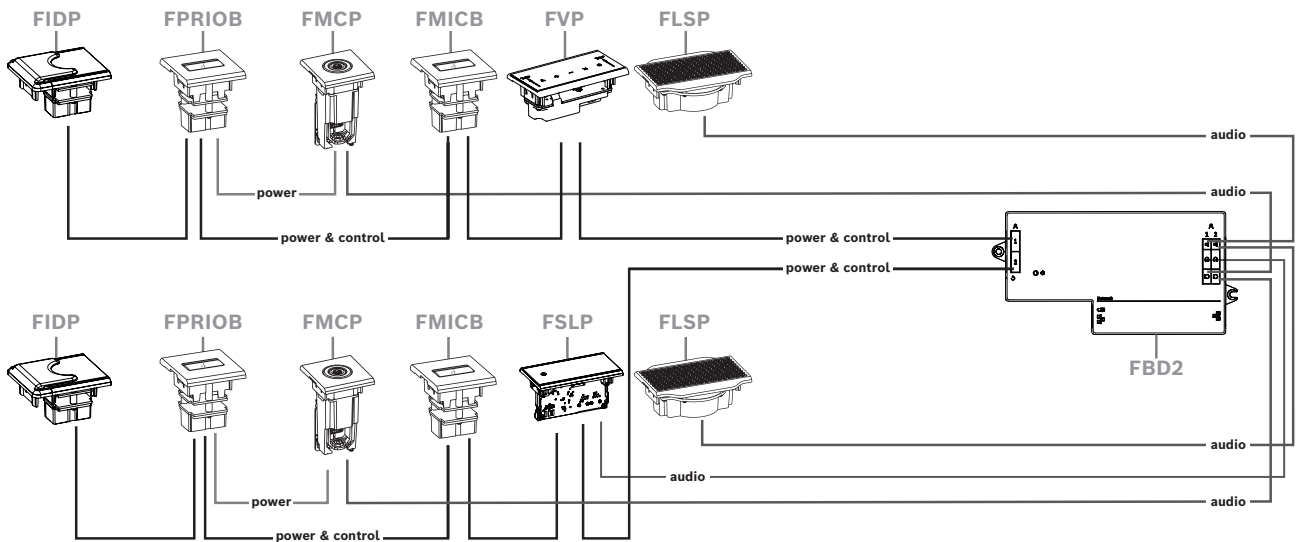

You can use:

- One DCNM-FSLP per side.
- One DCNM-FMCP per side.
- One DCNM-FLSP per side.
- Up to four CAN connected panels per side. Refer to Panels per side in *DCNM-FBD2 Flush base device*, page 65 for more information on CAN connected panels.

Note:

A chairperson seat with the functionalities of voting, language selection and identification, as well as buttons for priority and microphone, will use more than four panels. Both sides of the DCNM-FBD2 will be required.

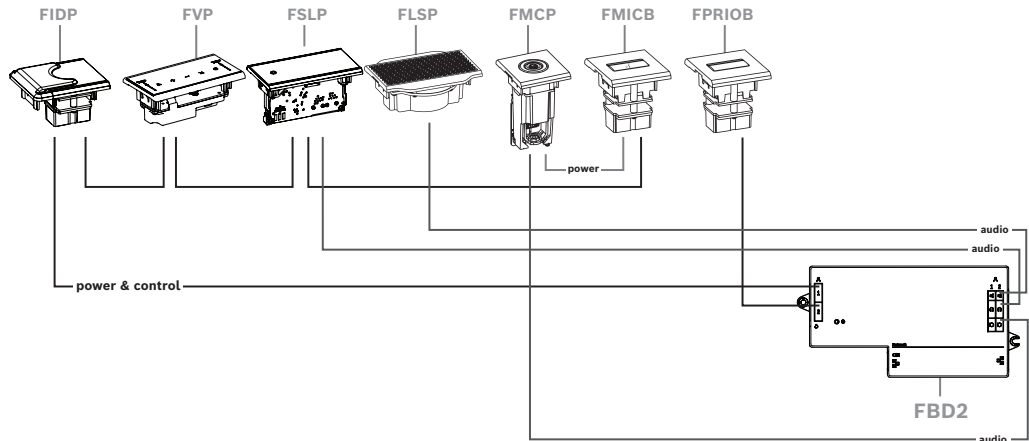

Four participant seats, with each pair sharing a microphone

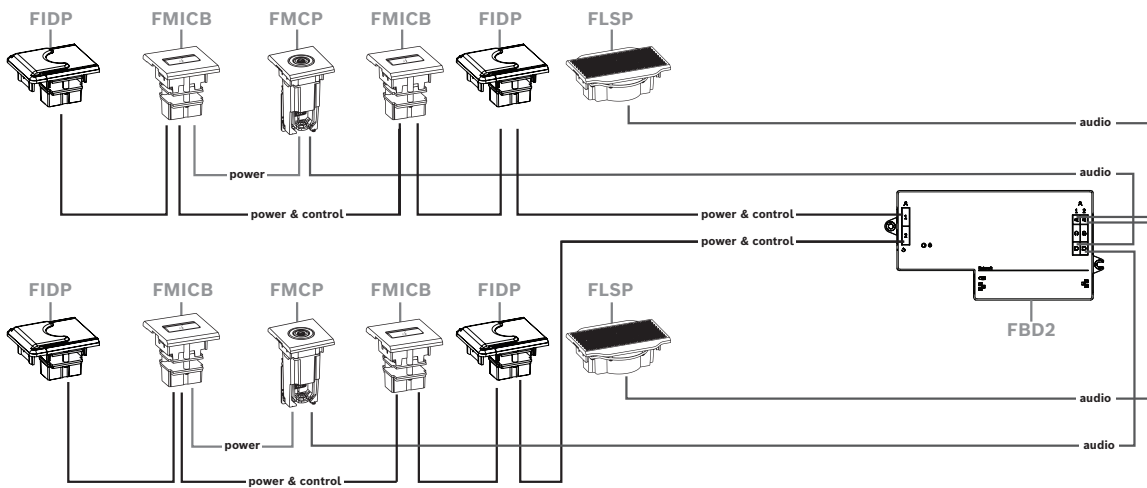

You can use:

- Two DCNM-FMICB per side.
- Two DCNM-FPRIOB per side.
- Two DCNM-FIDP per side.
- Two DCNM-FVP per side.

Note: Per side, there only can be four CAN connected panels. Refer to Panels per side in *DCNM-FBD2 Flush base device*, page 65 for more information on CAN connected panels.

One participant or chairperson seat with two microphones

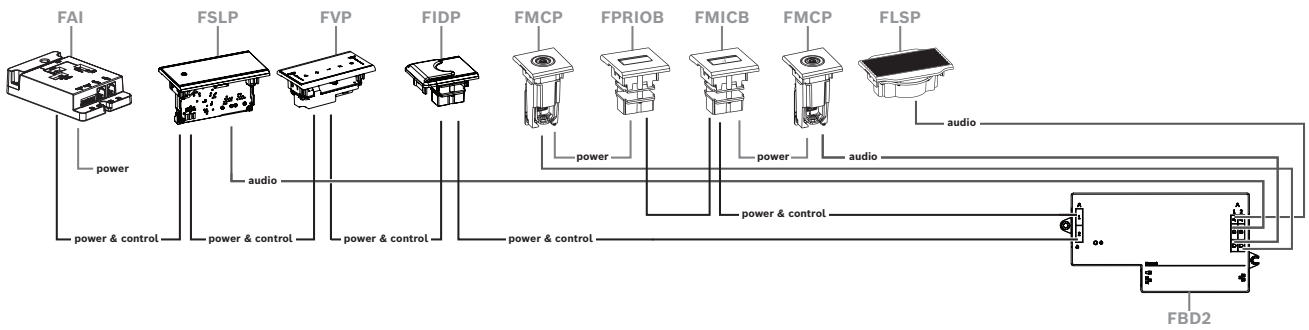

- If your setup does not require a DCNM-FPRIOB use the DCNM-FAI to power and control the second DCNM-FMCP. Refer to *DCNM-FAI Flush audio interface*, page 76 for more information on the connection to the second DCNM-FMCP.
- To create a rostrum seat that does not require any panels, connect two DCNM-FMCP to the DCNM-FAI for power and control.



Notice!

Always power both DCNM-FMCP through the DCNM-FAI in this kind of setup.

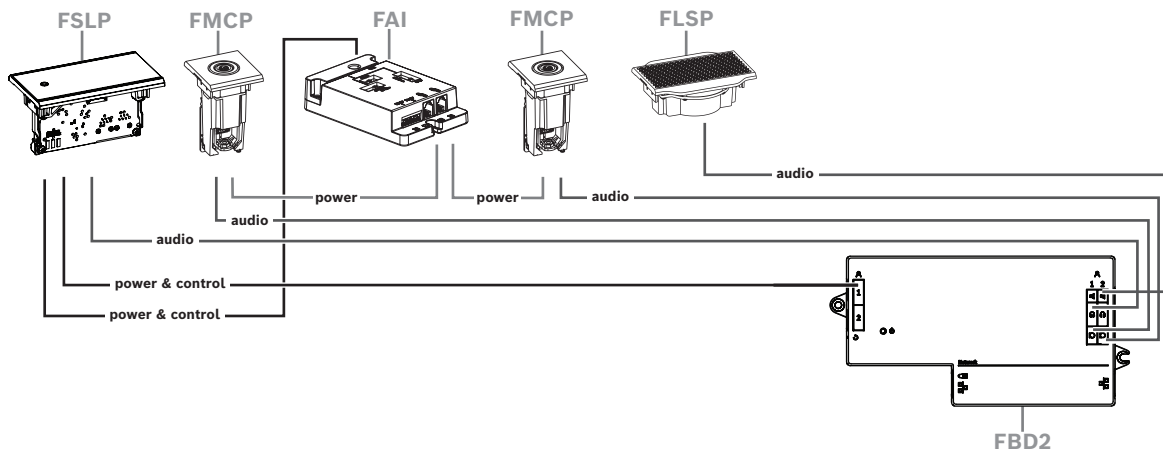

Figure 7.17: Rostrum seat with two microphones and without buttons

- Assign both the 1-A and the 2-A devices to the same seat in the meeting application. This automatically configures the DCNM-FBD so that the audio level is equal to a seat with 1 microphone.
- You can use up to four CAN connected panels per side. Refer to Panels per side in *DCNM-FBD2 Flush base device*, page 65 for more information on CAN connected panels.

7.3.13 DCNM-FSL Flush language selector

Use the flush language selector in setups without a microphone. It is ideal for when the participants need to select their preferred language to listen to the meeting but do not have to actively participate.

For a simple mounting in an armrest or other areas with limited space, the DCNM-FSL is powered via PoE utilizing a CAT-5E cable.

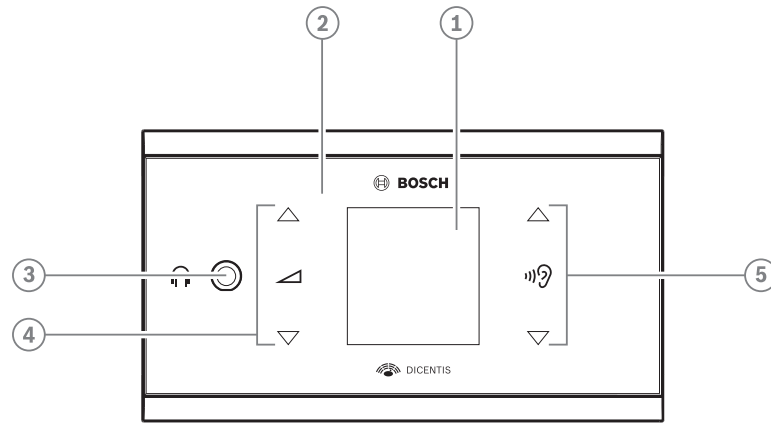

Item	Description
1	LCD screen
2	Capacitive touch screen
3	3.5 mm stereo jack for headphone
4	Headphone volume control
5	Language selection buttons

- The DCNM-FSL display turns on when a headphone is connected.
- The DCNM-FSL display automatically turns off when it is not used for 10 seconds. It will turn on again once you touch the volume control or language selection buttons.

Connect the language selector to a PoE switch in the DICENTIS network with a CAT-5e cable.



Notice!

Assign the DCNM-FSL Flush language selector to the same seat as the microphone so that the language selector headphones will automatically chose the language assigned to the participant. The language selector will decrease the volume level of the signal sent to the headphones when the microphone is active to prevent acoustic feedback.

External headphones socket

You can connect an external headphones socket to the language selector (e.g. a 3.5 mm headphones socket). The external headphones socket must be connected to a plug or to solder pads.

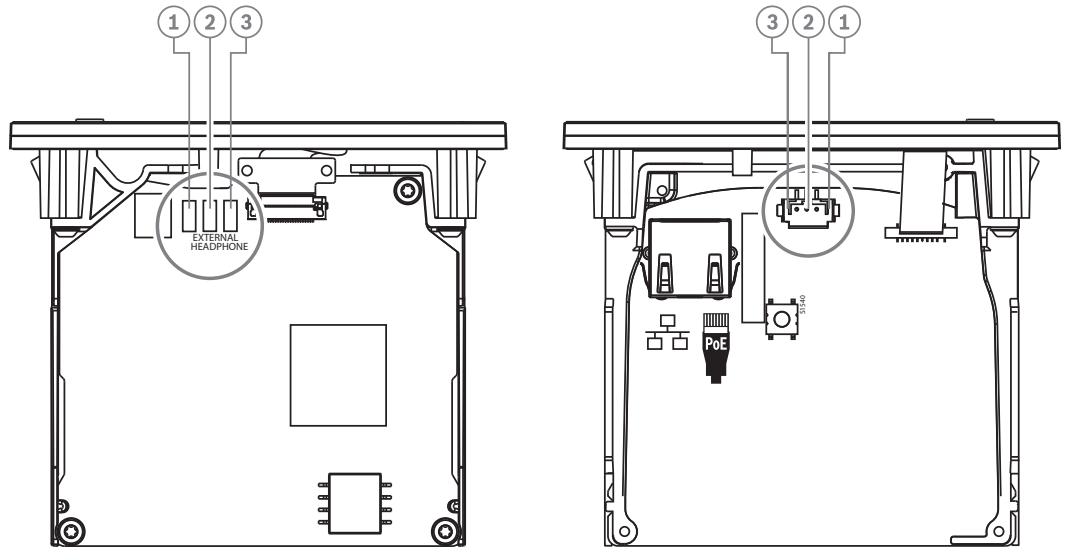

Figure 7.18: External headphones connection

The solder pads , external headphone connector, and built-in 3.5 mm socket are internally connected.

Plug (pin)	Solder pad	Signal
1	Left solder pad	Detect
2	Center solder pad	Signal
3	Right solder pad	GND

Table 7.16: External headphones connection



Notice!

You can connect, for example, an AMP173977-3 socket to the external headphones plug of the language selector.



Warning!

When using the external sockets of the DCNM-FSL, make sure that all connections are electrically floating. In case any connections are part of an earth loop, unexpected system behavior can occur.



Warning!

To prevent the user from suffering an unpleasant ESD discharge while inserting the headphones into the connector, always use a headphone connector with a plastic front in combination with the external headphone connection.

External headphone connection

When using an external headphone connector, please install it according to the electrical diagram below (wiring and jack connector).

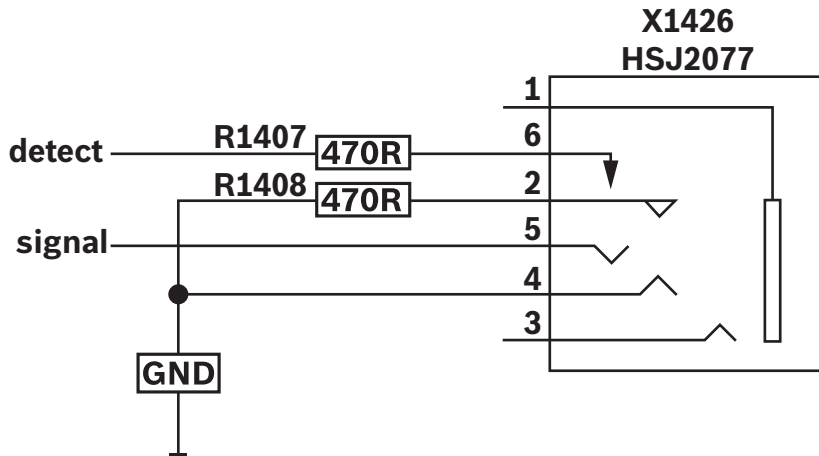

Figure 7.19: External headphone connector diagram

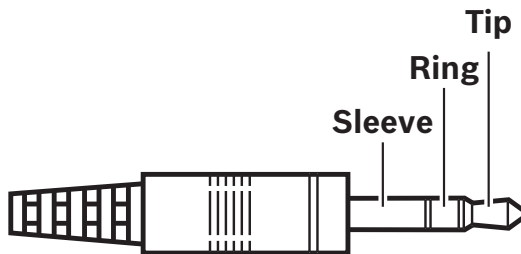

Figure 7.20: Headphone jack connection

	Tip	Ring	Tip	Sleeve
Normal	Audio R	Audio L		GND
DCNM-FSL	Signal	GND		<i>Not connected</i>

Table 7.17: Headphone jack connection



Notice!

The jack connector must include internal plug detection, which is used to enable the display. The display will not turn on if you use an incorrect connector (it should have a "jack inserted" switch). If you do not want to use this function, you must connect the detect signal to GND, so that the device thinks that a headphone is connected. Please note that this will cause the buttons' LEDs to be always on, which results in a shortened lifetime of the buttons' LEDs.

7.4 DCNM-IDESK / DCNM-IDESKVID Interpreter desk

The Interpreter desks (DCNM-IDESK and DCNM-IDESKVID) are used to:

- Interpret the floor language (channel A) in a meeting or conference.
- Relay the interpretation to various target languages via channel selection (channel B or C).

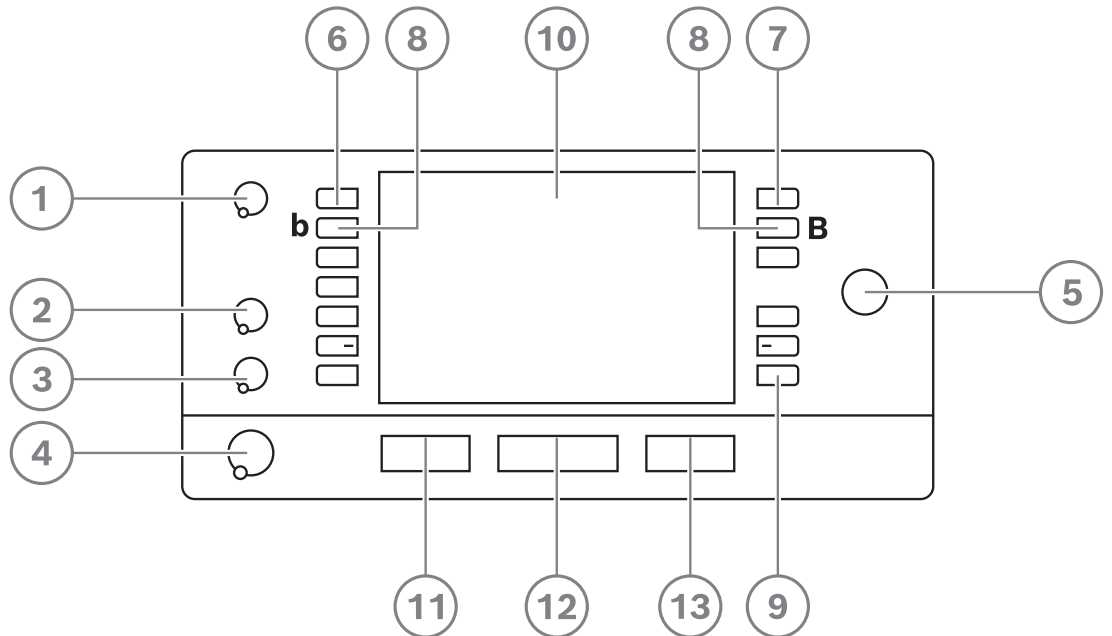

Item	Description	Function
1	Loudspeaker volume knob	Adjusts the volume level of the signal that is sent to the loudspeaker of the interpreter desk.
2	Treble knob	Adjusts the level of the treble of the signal that is sent to the headphones.
3	Bass knob	Adjusts the level of the bass of the signal that is sent to the headphones.
4	Headphones volume knob	Adjusts the volume level of the signal that is sent to the headphones.
5	Menu knob	Rotary control with integrated push button to configure and operate the interpreter desk.
6	Pre-select buttons	Allows the interpreters to select a channel from which they can render an interpretation (input).
7	Output buttons	Sets the output the target language will be sent to (A, B, C).
8	b - B buttons	Press these 2 buttons (with a small raised dash) at the same time to enter the installation mode and assign the device to a booth and desk. Refer to the DICENTIS Configuration manual, chapter "Configuring an IDESK (directly on the device)" on how to configure the interpreter desk.

Item	Description	Function
9	Assignable buttons	Assign functions to the assignable buttons through the Meeting application if the DCNM-LIPM license is available. Press and hold the button and rotate the knob to select which of the assigned buttons you will use. Refer to the DICENTIS Configuration manual, chapter "Meeting application" > "Configure" > "Interpreter desks" for detailed information on the functions.
10	Display	Shows the configuration, user menus and provides user feedback.
11	Floor / Auto-relay button	Sets the source of the interpretation.
12	Microphone button	Enables or disables the microphone. The microphone button has a red LED that comes on when the microphone is enabled (on-air). A green LED shows that the booth is not in use.
13	Mute button	Temporarily disables the microphone.

Connecting interpreter desks

Two RJ45 compatible connections for system communication and power are available for quick and easy connection of the interpreter desks. Loop-through cabling can be applied by using DICENTIS System cables or star cabling using standard CAT-5e cables and PoE switches.

Installing interpreter desks

The interpreter desks can be installed free-standing or fixed in more permanent installations (table-top) using mounting screws.



Warning!

The screws must be M3 and should not be screwed in deeper than 5 mm (0.2 inches) to avoid damaging the device.

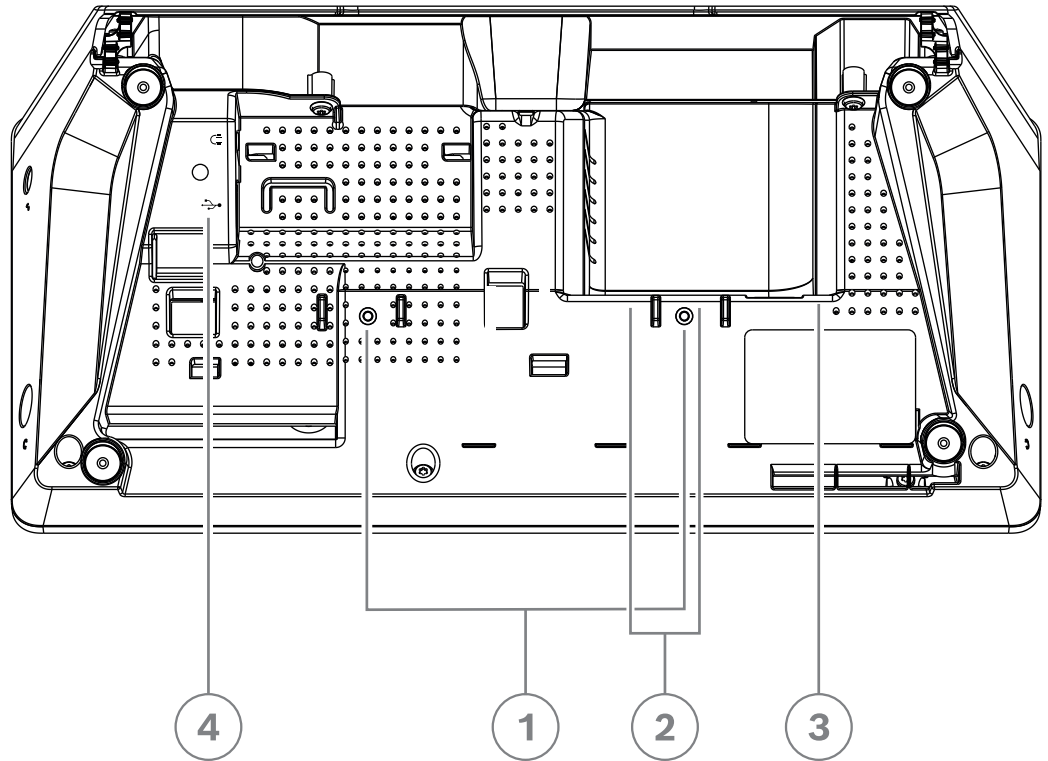

Figure 7.21: DCNM-IDESK / DCNM-IDESKVID bottom view

Item	Description
1	Screw insert for fixed installation
2	2 x RJ45 connection input/output for system power cable
3	HDMI video output (DCNM-IDESKVID only)
4	USB connector for the DCNM-IDESKINT On-air & telephone interface DCNM-IDESK. Refer to <i>DCNM-IDESKINT On-air & teleph. DCNM-IDESK</i> , page 42.



Notice!

The HDMI outgoing current is limited at 60mA, while the official HDMI standard specifies 55 mA. Some HDMI to VGA converters may require more current, which may result in unexpected behavior or a non-working converter.

7.5 DICENTIS Microphones

The DICENTIS Microphones are the DCNM-HDMIC High directive microphone, the DCNM-MICL/S Stem microphones, and the DCNM-MICSL/LS Screw lock microphones. These are typically used with the DICENTIS devices.

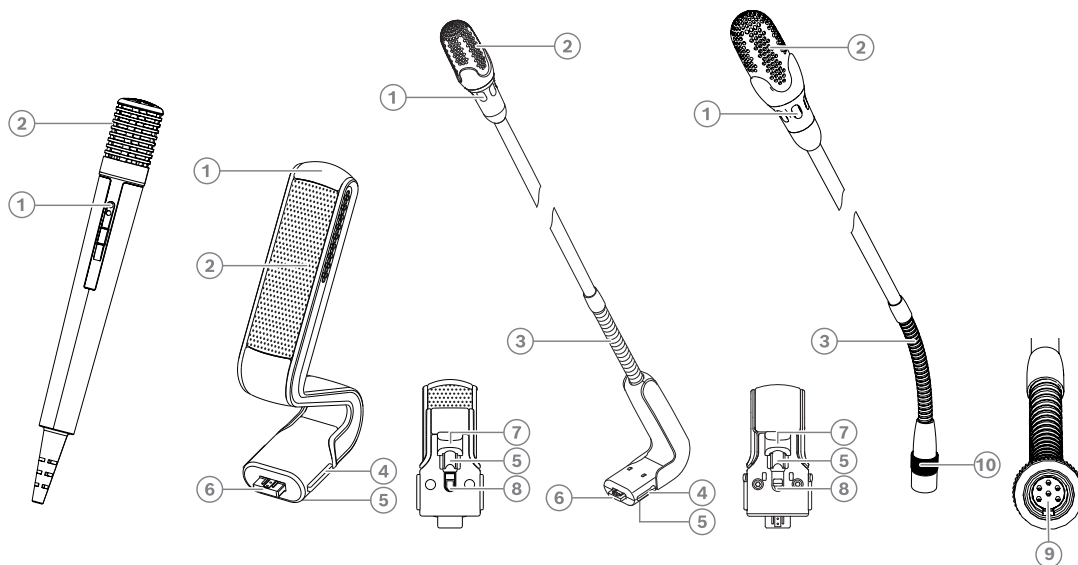

Figure 7.22: DCNM-FHH / DCNM-FHHC, DCNM-HDMIC, DCNM-MICS / DCNM-MICL and DCNM-MICSL / DCNM-MICSL

Number	Description
1	LED indicator
2	Microphone grill
3	Adjustable stem
4	Connection guidance
5	Slider guidance
6	Connector plug
7	Lock-slider for lock release (press and shift to release)
8	Lock
9	Device connector
10	Screw lock

How to connect or remove the microphones

The microphones can be easily connected to the DICENTIS devices:

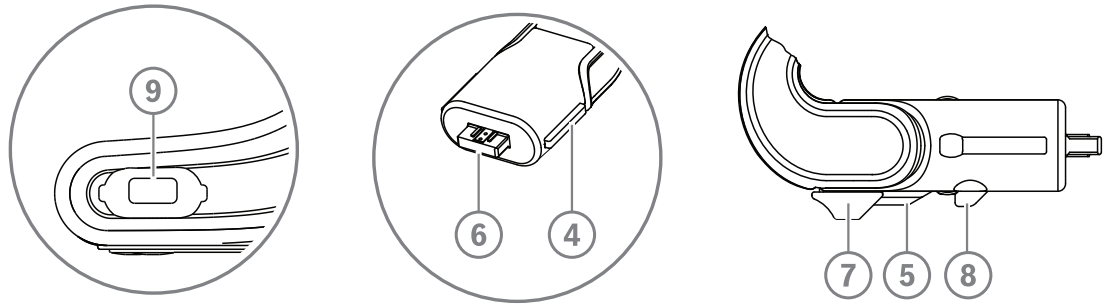

Figure 7.23: DCNM-HDMIC or DCNM-MICS / DCNM-MICL connection

1. Gently guide the connection guidance (4) into the DICENTIS device microphone connector (9).
2. Gently push the connector plug (6) into the device microphone connector (9) until the connection lock (5) fits/click into place.
- To remove the microphone from the device: Shift lockslider (7) towards the device and hold in place lock release (8) and pull out the microphone.

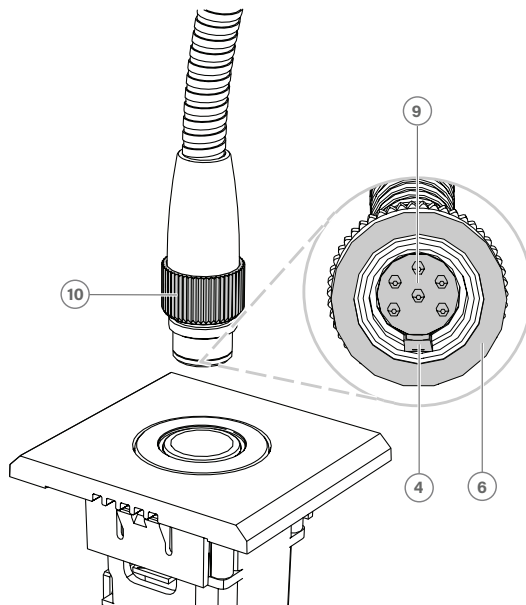

Figure 7.24: DCNM-MICSLL / DCNM-MICSLS connection

1. Gently guide the connection guidance (4) into the DICENTIS microphone panel connector (9).
2. Gently push the connector plug (6) into the microphone panel connector (9) and rotate the screw lock (10) clockwise.
- To remove the microphone from the panel: Rotate the screw lock (10) counter clockwise and pull out the microphone.

Refer to *DCNM-FHH / DCNM-FHHC Flush hand held microphones*, page 82 to see how to connect them.

7.6 DCNM-MMDSP Anti-reflection foil

The DICENTIS anti-reflection foil can be used to protect the tempered glass screen of a DICENTIS multimedia Device.

Installation procedure

1. Use the included alcohol swab and the microfiber fabric to clean the device LCD screen before installation.
2. Peel the positioning adhesive release paper from the rear of anti-reflection foil.
3. Position the anti-reflection foil on the device LCD screen, and then fix the positioning adhesive to the side of the device.
4. Open the anti-reflection foil, and use the “cleaning stick” to clean surface dust from the LCD screen.
5. Peel the protective film from the other side of the anti-reflection foil.
6. Lightly press the anti-reflection foil on to the LCD screen. If air bubbles are trapped under the anti-reflection foil, use the “squeegee” to remove them.

7.7 DICENTIS Card holders

7.7.1 DCNM-NCH Name Card Holder

The name card holder (1) can be used to permanently display the participant’s name on the rear of a DICENTIS multimedia Device. The name card holder has two magnets (2) that allow it to be easily attached to, and removed from, the rear of the device.

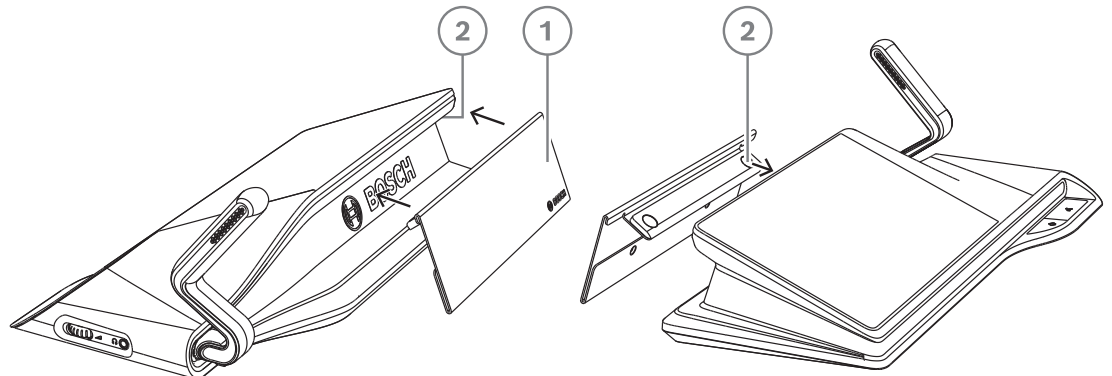

Figure 7.25: DCNM-NCH assembly

Item	Description
1	Name card holder.
2	Magnets.



Notice!

A paper insert template is included on the DVD that can be downloaded at: <https://licensing.boschsecurity.com/software>

7.7.2 DCNM-DICH ID card holder for DCNM-D

The ID card holder for the DICENTIS Discussion devices is designed for the identification mode. As long as the card remains in the ID card holder, the participant will be logged in. When the card is removed, the participant will be logged out.

This accessory cooperates with the built-in Near Field Communication (NFC) contact less tag reader of the DICENTIS Discussion devices. The identification mode is configured in the DICENTIS software.

The DCNM-DICH can be used with the DCNM-DE, the DCNM-DSL, and the DCNM-DVT.

Fixate the ID card holder easily by removing the protective foil at the rear, position it at the left side of the DICENTIS Discussion device, and press it firmly down as shown in the picture below:

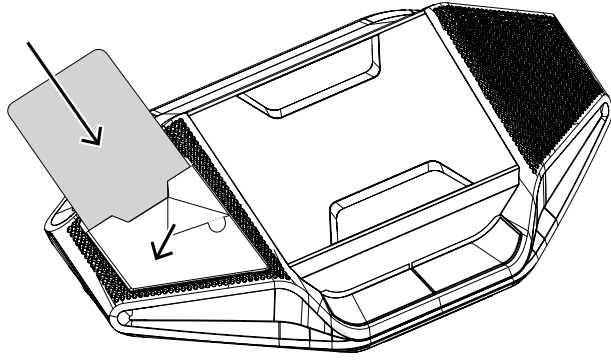

8 Installation Test

An installation test is needed to prevent connection mismatches and find potential product defects at an early stage. Not to do so could result in a system malfunctioning.

Each DICENTIS device has its own built-in diagnostics, which can be used for faultfinding.

The diagnostics starts as soon the DICENTIS device is powered on. The DICENTIS

Conference System does not have to be configured with, and connected to, the system controller PC.

Preconditions

1. All system network cables are connected to the devices.
2. The Audio processor and powering switch and Powering switch(es) are installed.

Start the test

Power on the Audio processor and powering switches and Powering switches used in the system: Each connected Test device powers on and initializes.

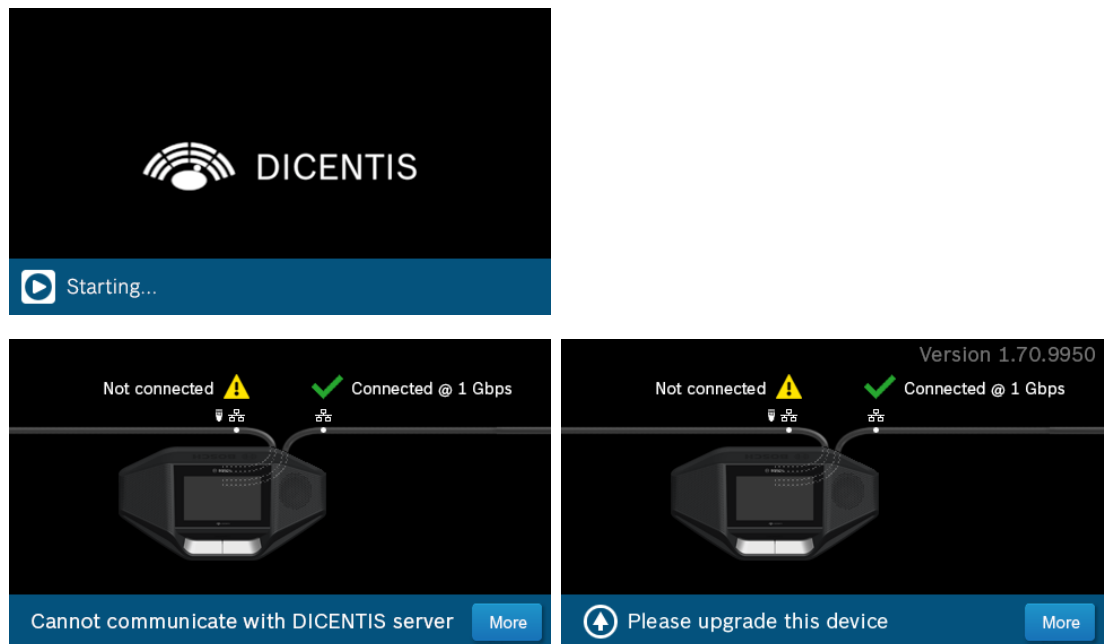

1. After the DICENTIS multimedia Device / the DICENTIS discussion Extended have initialized, the diagnostic screen is shown.
2. If the text “Link down” is shown:
 - The network cable is not connected or defective.
 - The device is only connected with one system network cable (“Link down” is shown on the side where the device is not connected).
3. If the system network cable is correctly connected to the network, the network speed is shown.
4. If the DICENTIS multimedia Device / the DICENTIS discussion Extended are connected to an Audio processor and powering switch, Powering switch or another multimedia device, and 100 Mb is shown:
 - Not all wiring inside the system network cable connector is correctly connected or broken. You need to check the wiring and connector.
 - If the cable is connected to a 100 Mb switch, it is correct.
5. Click the info button to see additional information of the multimedia device.
6. When everything is correctly connected, and the device does not have the application software, it shows the text “Please download software”.

7. Now the device can be downloaded:
 - Downloading devices is not covered in this manual. Refer to the DICENTIS configuration manual on how to download the devices.

Customer service

If a fault cannot be resolved, please contact your supplier or system integrator, or go directly to your Bosch representative.

Bosch Security Systems B.V.

Torenallee 49

5617 BA Eindhoven

Netherlands

www.boschsecurity.com

© Bosch Security Systems B.V., 2024

Building solutions for a better life.

202402011648