



BOSCH

Modular fire panel

FPA-5000 | FPA-1200



en

System Information

Table of contents

1	Notes	6
2	Product Description	6
2.1	FPA-1200 Fire Panel and FPA-5000 Fire Panel with Functional Modules	6
2.2	Panel controller	11
2.2.1	MPC Panel Controller	11
2.2.2	FPE-8000-SPC FPE-8000-PPC FPE-2000-SPC FPE-2000-PPC panel controller	13
2.3	Remote keypad	16
2.3.1	FMR-5000-C Remote keypad	16
2.3.2	FPE-8000-FMR Remote keypad	16
2.4	Housings for Frame Installation	18
2.5	Housings for Wall Mounting	21
2.6	System Overview	22
2.7	Networking	27
2.8	Connection to BIS	27
2.9	Connecting a Voice Alarm System	27
3	Planning	28
3.1	General Information	28
3.2	Detection Points	29
3.3	Address Setting	30
3.4	Topologies in Local Security Network	31
3.5	Failure handling in Local Security Network	33
3.6	Redundancy	34
3.7	Achievable Cable Length with LSN 0300 A	36
3.8	Achievable Cable Length with LSN 1500 A	38
3.9	Examples of Housing Equipment	42
3.10	Configuration of BCM Battery Controller Module	43
3.11	Protective earth and equipotential bonding	47
4	Installation	47
4.1	General Information	47
4.2	Quick Installation Guide	48
4.3	Installation of Housing Components	49
4.3.1	Installation Instructions for Housing	50
4.3.2	Installation Dimensions for Wall Mounting Housing	52
4.3.3	Installation Dimensions for Frame Installation Housing	58
4.3.4	Installation Dimensions for Mounting Frames	61
4.3.5	Installation Kits for 48 cm (19") Racks	64
4.4	Accessories for Housing	66
4.4.1	RLE 0000 A Junction Board	66
4.4.2	HMP 0003 A Mounting Plate for Mounting Frame	68
4.4.3	FPO-5000-EB Earth Bar	70
4.5	Power Supply Brackets	70
4.5.1	FPO-5000-PSB-CH Power Supply Bracket	72
4.5.2	FPO-5000-PSB1 Power Supply Bracket	76
4.6	UPS 2416 A Universal Power Supply 24 V/6 A	77
4.7	Panel Rails	83
4.7.1	PRS-0002-C Panel Rail Short for 2 Modules	83
4.7.2	PRD 0004 A Panel Rail Long for 4 Modules	85
4.7.3	Panel Rail Installation	86

4.8	MPC Panel Controller	89
4.9	Functional Modules	100
4.9.1	Installation and Removal	100
4.9.2	ANI 0016 A Annunciator Module	101
4.9.3	BCM-0000-B Battery Controller Module	101
4.9.4	CZM 0004 A 4 Zone Conventional Module	106
4.9.5	ENO 0000 B Fire Service Interface Module	107
4.9.6	FPE-5000-UGM Interface Module	108
4.9.7	IOP 0008 A Input/Output Module	109
4.9.8	IOS 0020 A 20 mA Communication Module	110
4.9.9	IOS 0232 A RS232 Communication Module	111
4.9.10	LSN 0300 A LSN improved Module 300 mA	112
4.9.11	LSN 1500 A LSN improved Module 1500 mA	113
4.9.12	NZM 0002 A Notification Appliance Zone Module	115
4.9.13	RMH 0002 A Relay Module for Mains Voltage	116
4.9.14	RML 0008 A Relay Module for Low Voltage	117
4.9.15	Accessories for Functional Modules	118
4.10	Cable Sets	119
4.11	Extended line monitoring (VdS 2540, VdS 2543)	120
4.12	FPP-5000 External Power Supply Unit Kit 24 V/6 A	120
4.13	THP 2020 A Thermal Printer	122
4.14	Remote Keypad	126
5	Commissioning	141
5.1	Notes	141
5.2	Documentation	141
5.3	Quick Guide for Commissioning	141
5.4	Functional Test	141
5.4.1	Preparation	141
5.4.2	Testing the Power Supply	142
5.4.3	Testing the Conventional and LSN Functions	142
5.4.4	Testing the Addressing/Activation	143
6	Maintenance and Service	143
6.1	Warranty	143
6.2	Repair	143
6.3	Disposal	143
6.4	Additional Documentation	143
7	Technical Data	144
7.1	System Limits	144
7.2	Power loss of components	145
7.3	Housing and Accessories	146
7.3.1	Housings for Frame Installation	146
7.3.2	Housings for Wall Mounting	146
7.3.3	PRS-0002-C Panel Rail Short for 2 Modules	147
7.3.4	PRD 0004 A Panel Rail Long for 4 Modules	147
7.3.5	FPO-5000-PSB1/FPO-5000-PSB-CH Power Supply Brackets	147
7.3.6	UPS 2416 A Universal Power Supply 24 V/6 A	148
7.4	Panel Controller and Remote Keypad	148
7.4.1	MPC	148
7.4.2	Remote Keypad	149

7.4.3	FSP-5000-RPS Programming Software	149
7.5	Functional Modules	149
7.5.1	ANI 0016 A Annunciator Module	150
7.5.2	BCM-0000-B Battery Controller Module	150
7.5.3	CZM 0004 A 4 Zone Conventional Module	151
7.5.4	ENO 0000 B Fire Service Interface Module	151
7.5.5	FPE-5000-UGM Interface Module	152
7.5.6	IOP 0008 A Input/Output Module	152
7.5.7	IOS 0020 A 20 mA Communication Module	152
7.5.8	IOS 0232 A RS232 Communication Module	152
7.5.9	LSN 0300 A LSN improved Module 300 mA	153
7.5.10	LSN 1500 A LSN improved Module 1500 mA	153
7.5.11	NZM 0002 A Notification Appliance Zone Module	154
7.5.12	RMH 0002 A Relay Module for mains voltage	154
7.5.13	RML 0008 A Relay Module for Low Voltage	155
7.6	FPP-5000 External Power Supply Unit Kit 24 V/6 A	155
7.6.1	FPP-5000 Kit	155
7.6.2	FPP-5000-TI Trouble Interface	156
7.6.3	FPP-5000-TI13 Communication Interface	156
8	Appendix	156
8.1	Options with requirements under EN 54-2:1997/A1:2006	156
8.2	Component Overview	157
8.2.1	Frame Installation Housings, Mounting Frames and Installation Kits	157
8.2.2	Wall Mounting Housings and Installation Kits	157
8.2.3	Accessories for Housing	158
8.2.4	Panel Rails	158
8.2.5	Power Supply Units, Power Supply Brackets, Batteries	158
8.2.6	Panel Controller/Remote Keypad	159
8.2.7	Functional Modules	161
8.2.8	Cable Sets	161
8.2.9	Thermal Printer	161
8.2.10	ETH/FOC Adapters	162
8.3	Additional documentation	162
8.3.1	Frame installation housings, mounting frames and installation kits	162
8.3.2	Wall mounting housings and installation kits	163
8.3.3	Accessories for housing	163
8.3.4	Panel rails	164
8.3.5	Power supply units	164
8.3.6	Panel controller Remote keypad	164
8.3.7	Functional modules	165
8.3.8	Cable sets	166
8.4	Special Applications	167
8.4.1	Controlling Extinguishing Systems	167
	Index	168

1 Notes



Danger!

The fire panel and devices contain live components.
Touching live components can result in electric shock.
Disconnect the power supply before all maintenance or installation work.



Notice!

Installation must only be carried out by authorized specialist personnel.



Notice!

Have maintenance and inspection work carried out regularly by trained, qualified personnel.
Bosch recommends a functional and visual inspection at least once a year.



Notice!

The fire panel is designed for indoor installation.
After installing batteries, the poles must be masked. Appropriate masking strips are included with the housing in which the batteries are installed.
Use fuses complying with national regulations to protect the power lines.



Notice!

Batteries must not be disposed of in household waste. Please take used batteries to the local collection points. See www.boschsecurity.com/xc/en/weee/ for further information.



Notice!

Consider national and local regulations when installing and operating the fire system.

2 Product Description

The fire panel is easily adapted to local requirements and regulations. Due to the different functional modules, country-specific characteristics are accommodated in the connection just as quickly as the respective alarm protocol.

2.1 FPA-1200 Fire Panel and FPA-5000 Fire Panel with Functional Modules

Compare FPA-1200 fire panel to FPA-5000 fire panel:

	FPA-1200	FPA-5000 (MPC-xxxx-C)
Ethernet interface to		
Building management system (BIS, FSM-5000-FSI)	•	•

	FPA-1200	FPA-5000 (MPC-xxxx-C)
UGM-2040 Hierarchy panel	•	•
Voice alarm system (Smart Safety Link)	•	•
Modularity (maximum number)		
LSN 0300 A modules	4	32
LSN 1500 A modules		11
Functional modules (including LSN modules)	6	46
Panel redundancy		
Redundant panel controller		•
Network		
Panel network	remote keypads	panels, remote keypads, servers
Max. number of nodes	4 (1 panel, 3 keypads)	32

The fire panel is available with two different types of housings:

- Wall mount housing
- Frame mount housing

The slim wall mount housings are for mounting directly to the wall. Frame mount housings require an additional frame between the housing and the wall. The frame lets space for e.g. cabling, media converters, and larger batteries. Special installation kits also allow installation in 19" racks.

The panel controller is the central component of the fire panel. A color display shows all messages. The touch screen is for operation of the entire system. The user-friendly interface adapts to various situations. This causes correct operation that is simple and clear as well as targeted and intuitive.

The fire panel is configured on a laptop using the FSP-5000-RPS programming software. The programming software enables further adaptation, e.g. to country-specific requirements and regulations.

The panels can be networked with one another and with the remote keypad using the Ethernet and the CAN bus interfaces.

The fire panel can be connected to the Bosch Hierarchy panel (UGM) and thus integrated into large-scale systems.

Connection to the Bosch Building Integration System BIS is possible via an Ethernet interface using an OPC server. The FSM-5000-FSI Software Interface Package allows custom integration to external management systems.

The panel can be connected to a voice alarm system. The Praesideo or PAVIRO system can be connected using an Ethernet interface. Plena voice alarm system can be connected via an RS232 module.

The remote keypad allows decentralized operation of the panel or the panel network.

System Overview

The figure below shows an example configuration:

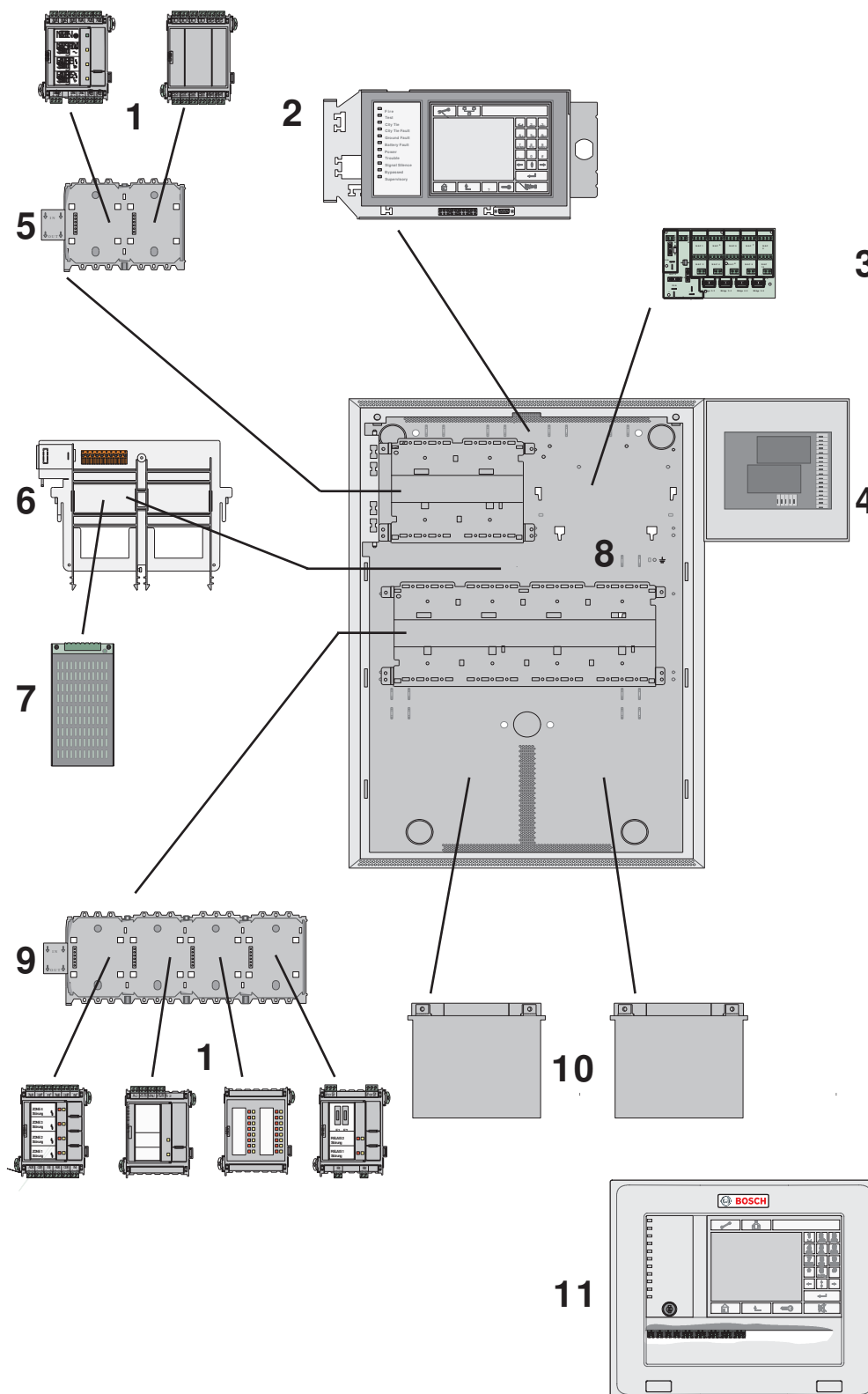

Figure 2.1: Example configuration

Position	Description	Position	Description
1	Functional modules	7	Power supply unit
2	Panel controller	8	Housing (in this case: HCP 0006 A)

Position	Description	Position	Description
3	Distributor, optional (RLE)	9	Panel rail, long
4	Fire brigade peripheral module	10	Batteries
5	Panel rail, short	11	Remote keypad
6	Power supply bracket		

Functions

The panel provides complete flexibility and thus customized solutions for any application. The configuration of the components is supported by Safety Systems Designer for fire alarm systems. The software provides information about the size and number of housings, the modules and the energy balance calculation.

Depending on specific requirements, the planning involves choosing from the following options:

- **Housing type (frame and wall mounting)**
 - Selection of a basic housing
 - Extension housing, optional
 - Power supply housing, optional
 - Installation kits (optional) for installation in 482.6 mm (19") racks
- **Panel controller**
 - Selection from a range of language versions
- **Panel rail**
 - Selection according to housing type and/or number of functional modules required
- **Power supply**
 - Batteries
 - Power supply units for additional power supply
 - Power supply brackets
 - The power supply brackets on frame installation housings are preinstalled ex works; for wall-mounted housings, power supply brackets can be selected as required.
- **Thermal printer**
 - THP 2020 A Thermal Printer
 - The thermal printer is used to document operating procedures on the panel, as well as alarm and fault messages. Plain text can also be printed. Programming is carried out via the programming software FSP-5000-RPS.
- **Additional accessories**
 - Front doors
 - Cable sets for special applications.
- **Functional modules**
 - Functional modules are independent, encapsulated units that can be inserted into any slot on the panel. The power supply and the data traffic with the panel are therefore provided automatically. The module is identified by the panel with no further settings and operates in the default operating mode (plug and play).
 - Wiring to external components is performed using compact connector/screw terminals. After a replacement, only the connectors need to be reinserted; there is no need for extensive rewiring.

Module	Description	Function
ANI 0016 A	Annunciator module	Indicating system statuses, with 16 red and 16 yellow freely programmable LEDs

Module	Description	Function
BCM-0000-B	Battery controller module	Controlling the power supply to the panel and the battery charge level
CZM 0004 A	Conventional zone module	Connecting conventional peripheral devices using four monitored conventional lines
ENO 0000 B	External notification module	Connecting fire service equipment complying with DIN 14675
FPE-5000-UGM	Module interface to UGM	Connection to UGM systems
IOP 0008 A	Input-output module	Individual displays or flexible connection of various electrical devices, with 8 independent digital inputs and 8 open collector outputs
IOS 0020 A	Communication module, 20mA	With S20 and RS232 interfaces
IOS 0232 A	Communication module, RS232	Connection of two devices using two independent serial interfaces, e.g. Plena or a printer.
LSN 0300 A	LSN bus module 300mA	Connection of an LSN loop with up to 254 LSN improved elements or 127 LSN classic elements at a maximum line current of 300 mA
LSN 1500 A	LSN bus module 1500mA	Connection of an LSN loop with up to 254 LSN improved elements at a maximum line current of 1500 mA or 127 LSN classic elements at a maximum line current of 300 mA
NZM 0002 A	Notification appliance zone module	Allows connection of two conventional, monitored notification appliance circuit lines
RMH 0002 A	Relay module high-voltage	Monitored connection of external elements with feedback, with two changeover contact relays suitable for switching mains voltage
RML 0008 A	Relay module low-voltage	For low voltage switching, with eight changeover contact relays

- Fire brigade peripheral module
A fire brigade peripheral module is connected via FPE-5000-UGM or via IOS 0020 A functional module. The fire brigade peripheral module FMF-ADP-TTY connects fire service devices e.g. a Fire service operating panel or a Fire brigade information center to the fire panel.



Notice!

Safety Systems Designer can be used to plan fire alarm systems that conform to the relevant limits (e.g. in terms of cable length and power supply).

**Notice!**

Safety Systems Designer for fire alarm systems enables the system dimensions, the energy requirements and the quantity and prices of the elements required to be estimated at each different phase in the planning process.

The software is designed for planners and engineering offices that want to produce a quotation for a fire alarm system.

**Notice!**

Trouble handling

A trouble indication disappears as soon as the triggering fault is rectified, and you have reset the trouble message. If you cannot reset a trouble message, then contact the service personnel.

Refer to

- *Networking, page 27*
- *Connection to BIS, page 27*
- *Connecting a Voice Alarm System, page 27*

2.2

Panel controller

2.2.1

MPC Panel Controller

The panel controller is the central component of the fire panel. All messages are shown on the color display. The entire system is operated via a touch screen. The user-friendly user interface adapts to various situations. This allows correct operation that is both simple and clear as well as targeted and intuitive.

The FSP-5000-RPS programming software enables adaption to project- and country-specific requirements.

For operating the panel controller and the keypad refer to the user manual (F.01U.258.929) available for download at www.boschsecurity.com.

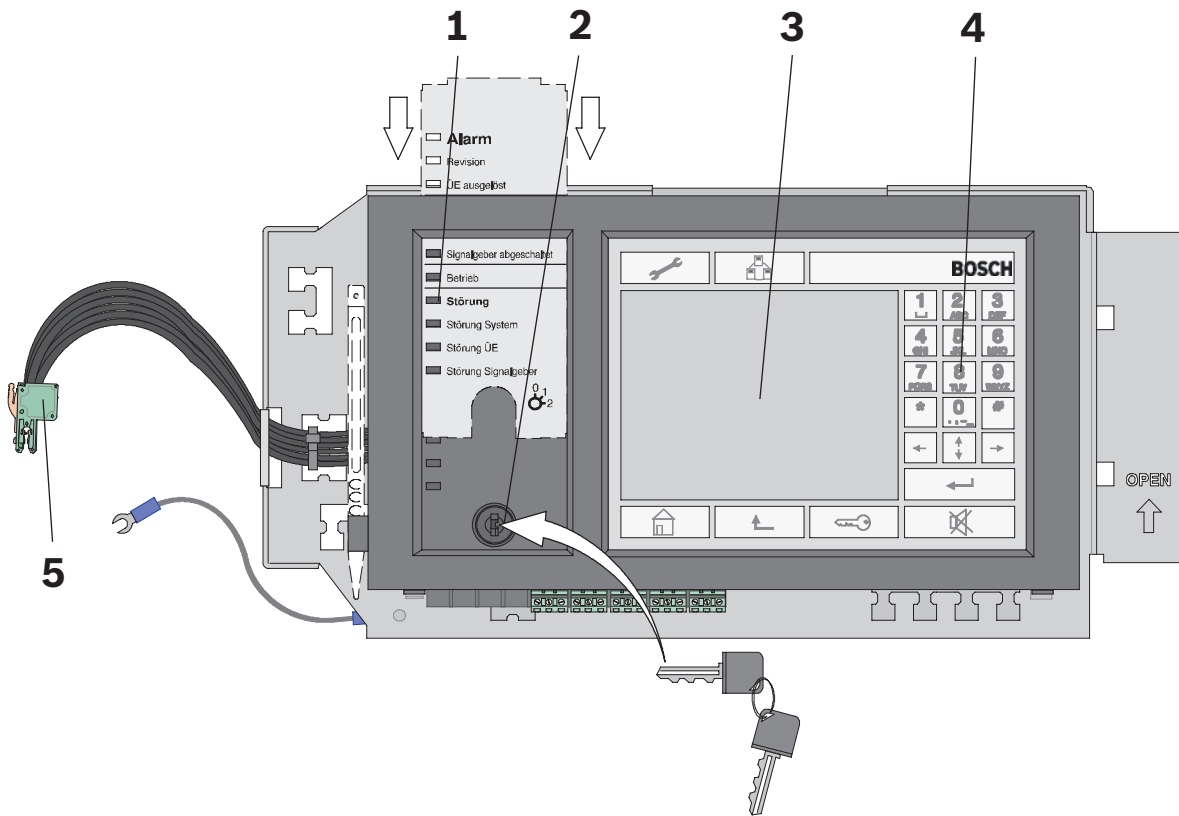

Figure 2.2: Overview of MPC system

Position	Description
1	LEDs for displaying the operating status, with labeling strips
2	Key switch
3	Touch screen
4	Membrane keys
5	CAN bus, internal

Networking

Up to 32 panel controllers, remote keypads and OPC servers can be combined to form a network.

Alarm Indication

The display element is an TFT touch screen with automatically activated backlighting. 12 LEDs provide continuous information about the operating status of the panel or system. Additional LED indicator modules each with 16 detection points can be used to provide visual indication of alarms or faults.

Operation and Processing of Messages

The panel is operated and all messages are processed on the functionally designed operating panel with the integrated TFT touch screen. There are permanent keys on the right, at the bottom, and along the top of the display as well as variable virtual keys located in the touch screen area.

The language for the menu navigation can be selected as required.

Below the status LEDs is a key switch with two programmable positions, e.g.:

- for switching between day/night mode, or

- for switching local alarm on/off (internal/external alarm)

Interfaces

A USB interface is provided to quickly transfer the required configuration to the panel controller. There is also an Ethernet interface for adding the BIS software to the local network, for example.

Saving and Printing Messages

Incoming messages and events are saved internally and can be viewed on the display. A log printer for printing incoming messages can be connected.

2.2.2

FPE-8000-SPC | FPE-8000-PPC | FPE-2000-SPC | FPE-2000-PPC panel controller

The panel controller is the central component of the fire panel. All messages are shown on the color display. The entire system is operated via a touch screen. The user-friendly user interface adapts to various situations. This allows correct operation that is both simple and clear as well as targeted and intuitive.

The FSP-5000-RPS programming software enables adaption to project- and country-specific requirements.

For operating the panel controller and the keypad refer to the user manual (F.01U.378.877) available for download at www.boschsecurity.com.

Licenses

The panel controller is delivered with a hard coded software license. This software license is implemented during production and cannot be modified, revoked or transported. The license defines the maximum panel network size and availability of certain features and interfaces. In total 4 different licenses are available.



Notice!

Building Management System

A premium license is required for each panel that needs to be available in a building management system (e.g. BIS, FSM-5000-FSI). It is not sufficient to equip only one panel of the network with a premium license, if you need all panels of the network in the building management system.



Notice!

UGM-2040 hierarchy panel

A premium license is required for each panel that needs to be available in the UGM-2040 hierarchy panel. It is not sufficient to equip only one panel of the network with a premium license, if you need all panels of the network in the hierarchy panel.



Notice!

Voice alarm system

Each fire panel which is physically connected to a voice alarm system (Praesideo, PAVIRO or Plena) via Smart Safety Link needs a premium license.



Caution!

Do not use any pointed or sharp objects (e.g. screw drivers, pens, etc.) when operating the touch-sensitive display. The touchscreen may not be exposed to direct sunlight. Both can seriously damage the touchscreen.



Warning!

The power button must be used to switch off the device before removing the power supply. It may not be disconnected from power supply while system is running. The device may be damaged if this procedure is violated. Not following this procedure may result in loss of warranty. Refer to user guide for further information.

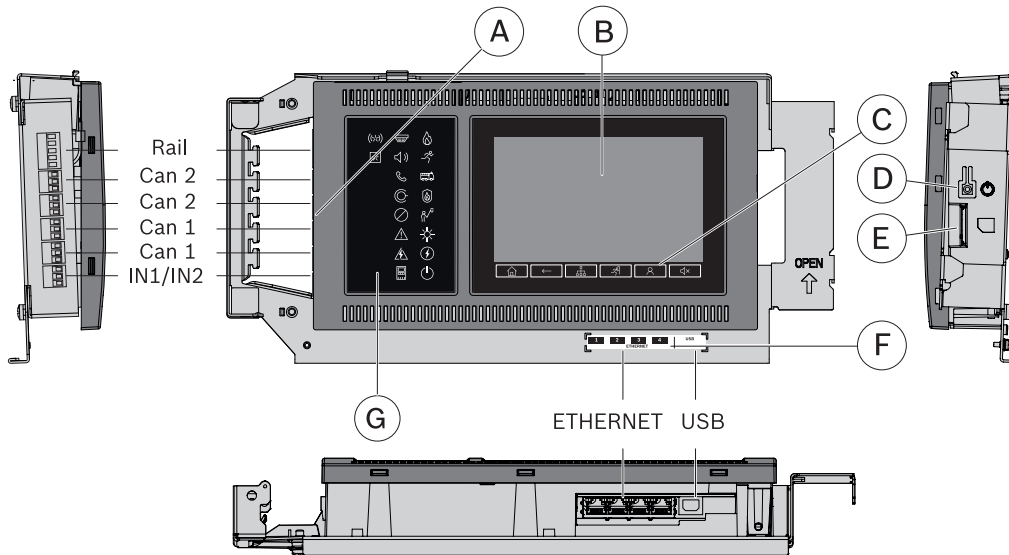

Figure 2.3: Overview of panel controller

Pos.	Designation	Function
A	Interfaces	Panel networking and inputs for internal device monitoring
B	Touchscreen	Operating the networked system through virtual buttons and variable display windows
C	6 fixed buttons	Standard entries
D	Power button	Shutdown and restart of the device
E	Memory card slot	Memory card reader for maintenance services
F	Ethernet ports	Panel networking and interface to various systems
G	18 LEDs	Indicating the operating status

Networking

A panel controller with premium license can be networked with up to 32 panel controllers, remote keypads and OPC servers.

Panels and keypads display all messages, or you can form a group of panels and keypads. Within one group, only messages of this group are displayed.

Alarm indication

All messages are shown on the display with a bright color. The displayed messages contain the following information:

- Message type
- Type of the triggering element
- Description of the exact location of the triggering element
- Logical zone and sub-address of the triggering element

At any time, the operator can request a status overview for each evacuation zone and each output connected to the fire protection equipment.

18 Icon LEDs give continuous information about the operating status of the panel or the system. A red icon LED shows an alarm. A blinking yellow icon LED shows a fault. A steady yellow icon LED shows a disabled function. A green icon LED shows proper operation. Two status LEDs, one red and one yellow, are programmable. The red one shows a self-defined alarm. The yellow one shows a self-defined fault or deactivation. Additional annunciator modules, each with 16 red and 16 yellow LEDs are available to indicate a larger number of self-defined alarms, faults or deactivations.

Operator management

The system can have up to 200 different registered operators. Login is permitted with a user ID and an 8-digit pin code.

There are four different authorization levels. Depending on the authorization level it is possible for the operator to do certain functions according to EN54-2.

Languages

The operator can change the language of the user interface. A printed quick user guide for each language is supplied with the package. Following languages are included: English, German, Bulgarian, Croatian, Czech, Danish, Dutch, Estonian, French, Greek, Hungarian, Italian, Latvian, Lithuanian, Polish, Portuguese, Romanian, Russian, Serbian, Slovak, Slovenian, Spanish, Swedish and Turkish.

Operation and processing of messages

For operating the panel, an 8 inch touch pad as input medium is put upon the display. There are 6 buttons with fixed functionality as well as 3 programmable function keys.

Examples for the assignment of the function keys:

- Set the panel controller to day mode, set the panel controller to night mode
- Enable detection points or outputs, disable detection points or outputs
- Set standard sensor sensitivity, set alternative sensor sensitivity

Each function key has a virtual status indicator.

At any time, an operator with sufficient user rights can activate each evacuation zone and each output connected to fire protection equipment via the user interface.

The panel controller features

- 2 CAN interfaces (CAN1/CAN2) for networking
- 1 Rail connector
- 4 Ethernet interfaces (1 / 2 / 3 / 4) for networking, prescribed usage:
 - 1 and 2 (blue): Panel network
 - 3 (green): Building management system, hierarchy panel, voice alarm system
 - 4 (red): Remote Services
- 2 signal inputs (IN1/IN2)
- 1 USB function interface for configuration via FSP-5000-RPS
- 1 Memory card interface

Saving and printing messages

The history log keeps incoming alarms and events internally. The history log has a capacity to store 10000 messages. The messages can be shown on the display, and you can export the messages. Additionally, you can connect a log printer via a serial interface module for real-time printing incoming messages.

Installation

Refer to the Installation guide for FPE-8000-SPC | FPE-8000-PPC | FPE-2000-SPC | FPE-2000-PPC panel controller (F.01U.347.557) available for download at www.boschsecurity.com.

Refer to

- MPC Panel Controller, page 89
- MPC, page 148

2.3 Remote keypad

2.3.1 FMR-5000-C Remote keypad

The remote keypad can be used to perform the same operating procedures as the panel itself, enabling a networked system to be operated decentrally.

Power can be supplied by the panel or an external power supply unit such as the FPP-5000.

The easy-to-install housing was designed for tilted installation and for surface or flush wall mounting.

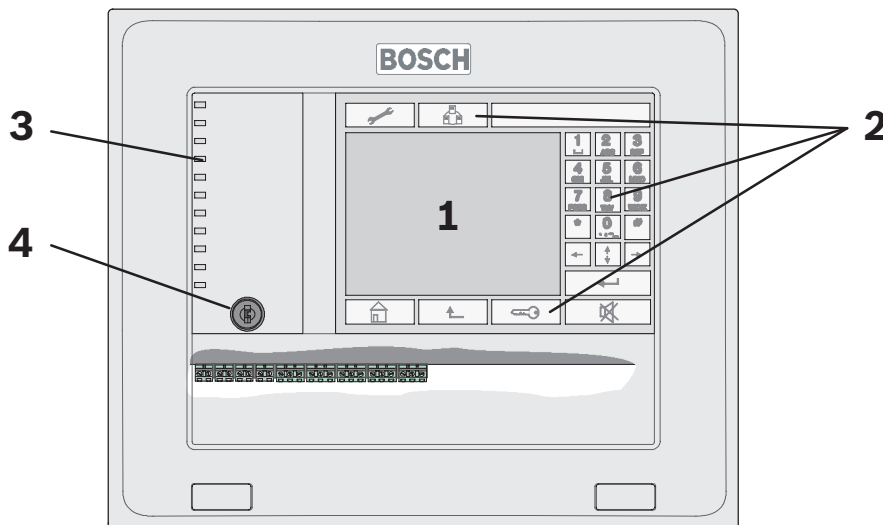

Figure 2.4: FMR-5000-C Remote Keypad

Position	Description
1	Touch screen
2	Membrane keys
3	LEDs for displaying the operating status
4	Key switch

For operating the panel controller and the keypad refer to the user manual (F.01U.258.929) available for download at www.boschsecurity.com.

2.3.2 FPE-8000-FMR Remote keypad

The remote keypad can be used to perform the same operating procedures as the control panel, enabling variable operation of a networked system. It has the following functional elements.

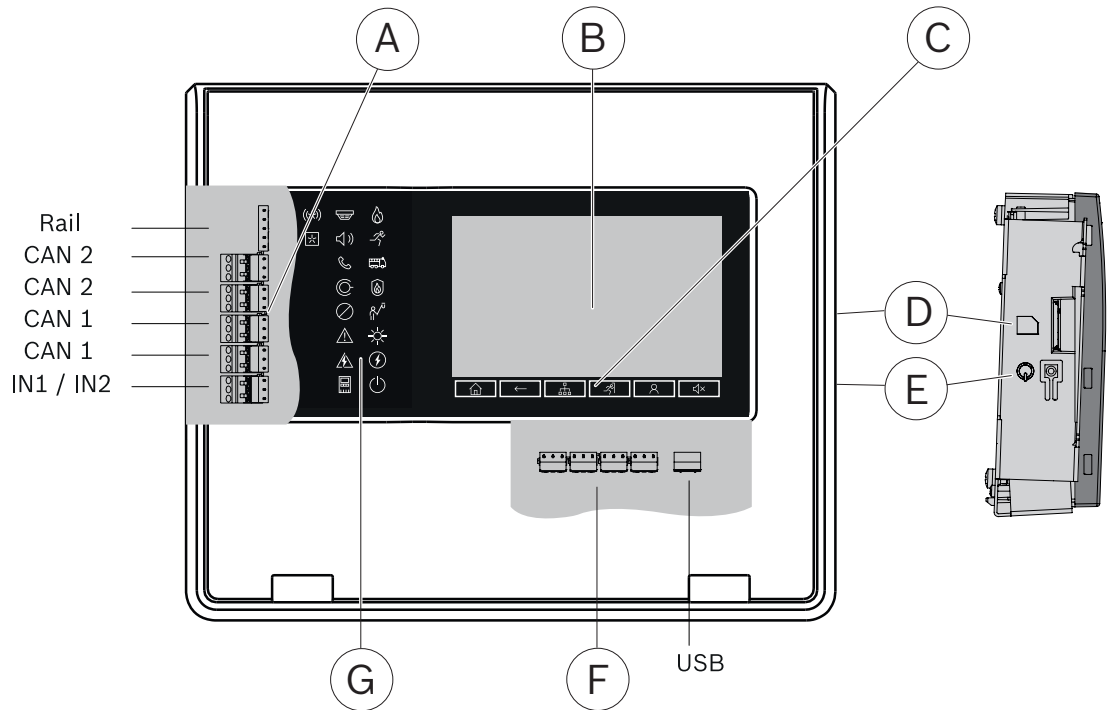

Pos.	Designation	Function
A	Interfaces	Power supply input, panel networking and inputs for internal device monitoring
B	Touchscreen	Operating the networked system through virtual buttons and variable display windows
C	6 fixed buttons	Standard entries
D	Memory card slot	Memory card reader for maintenance services
E	Power button	Shutdown and restart of the device
F	Ethernet ports	Panel networking and interface to various systems
G	18 LEDs	Indicating the operating status

It comes with easy-to-install housing for tilted installation and for surface or flush wall mounting. Power can be supplied by the panel or an external power supply unit such as the FPP-5000.

Installation

Refer to the installation guide for the FPE-8000-FMR Remote keypad (F.01U.347.558) available for download at www.boschsecurity.com.

For operating the panel controller and the keypad refer to the user manual (F.01U.378.877) available for download at www.boschsecurity.com.

Refer to

- MPC Panel Controller, page 89
- MPC, page 148

2.4 Housings for Frame Installation



Figure 2.5: Housings for frame installation

Frame installation housings are always used in conjunction with the associated mounting frame.

The housings are hooked into the mounting frame and can be swiveled to the front for installation and servicing. The mounting frames are screwed to the wall surface and hold the pre-cabling.

Alternatively to surface mounting, installation in 482.6 mm (19") racks is also possible using special installation kits.

12 V/45 Ah batteries can be used in the frame installation housing.

The modular system makes it easy to extend the system.

Housing Designs and Combinations

Two frame installation housings are available as a base unit:

- CPH 0006 A (for 6 modules) or
- MPH 0010 A (for 10 modules)

These housings can accommodate a panel controller with an operating and display unit.

The CPH 0006 A and MPH 0010 A basic housings can be extended to meet individual requirements using:

- EPH 0012 A extension housing for an additional 12 modules, frame installation
- PSF 0002 A or PMF 0004 power supply housing for two or four 12 V/45 Ah batteries respectively and an additional power supply unit.
- USF 0000 A Universal Housing Small, Frame Installation.

A power supply bracket for a UPS power supply is fitted ex-works in housing units

CPH 0006 A, PSF 0002 A and PMF 0004 A.

Mounting Frames

All mounting frames have integrated terminal blocks for the mains supply, integrated junction boards, as well as permanently installed cable ducts to facilitate clear and tidy cable routing.

The mounting frames are available in three sizes:

- FBH 0000 A Mounting Frame Large
- FMH 0000 A Mounting Frame Medium
- FSH 0000 A Mounting Frame Small

The housings for frame installation require the following mounting frames for surface-mounted version:

Housing type	Mounting frames
CPH 0006 A	FBH 0000 A
MPH 0010 A	FBH 0000 A
EPH 0012 A	FBH 0000 A
PSF 0002 A	FSH 0000 A
PMF 0004 A	FMH 0000 A
USF 0000 A	FSH 0000 A

Notes:

- All mounting frames have an opening for routing cables that is sealed with an insert. Pre-punched cable entries can be created from this insert.
- The FBH 0000 A and FHS 0000 A mounting frames are equipped with an earth bar ex works.
- For the FMH 0000 A, the FPO-5000-EB Earth Bar can be ordered as an extension if required.
- For continuous installation in combination, all mounting frames have T-shaped guide rails on the base and T-shaped grooves on the top.

Mounting Plate

An HMP 0003 A Mounting plate can be mounted in large mounting frames FBH 0000 A and FHS 0000 A; this mounting plate can be individually equipped. It contains fixing holes for a distributor rail.

USF 0000 A is fitted with a mounting plate ex works, which can be equipped as required. It contains fixing holes for two distributor rails.

Equipment Limits

The table below shows the maximum number of:

- Modules
- Panel rails (short PRS-0002-C, long PRD 0004 A)

Housing type	Modules	Short rails	Long rails
CPH 0006 A	6	1	1
MPH 0010 A	10	1	2
EPH 0012 A	12	-	3
PSF 0002 A	-	-	-
PMF 0004 A	-	-	-
USF 0000 A	-	-	-

The table below shows the maximum number of:

- Panel controllers
- UPS power supply units
- Batteries

Housing type	Panel controller	UPS power supply units	Batteries
CPH 0006 A	1	1	2 x 45 Ah
MPH 0010 A	1	-	-

Housing type	Panel controller	UPS power supply units	Batteries
EPH 0012 A	-	-	-
PSF 0002 A	-	1	2 x 45 Ah
PMF 0004 A	-	1	4 x 45 Ah
USF 0000 A	-	-	-

Installation Kits for 48 cm (19") racks

Special installation kits are available for installing the frame installation housing in 482.6 mm (19") racks:

Housing type	Installation kit, 482.6 mm
CPH 0006 A	FRB 0019 A
MPH 0010 A	FRB 0019 A
EPH 0012 A	FRB 0019 A
PSF 0002 A	FRB 0019 A
PMF 0004 A	FRM 0019 A
USF 0000 A	FRS 0019 A

No mounting frame is required when using the 482.6 mm installation kits.

Front Doors

The CPH 0006 A, MPH 0010 A and EPH 0012 A housings can be equipped with optional transparent front doors made of impact-resistant plastic, with a lock on the left or right:

- FDT 0000 A Front Door Transparent, lock right side
- FDT 0003 A Front Door Transparent, lock left side

Scope of Delivery

Housing type	Scope of delivery (each x 1)
CPH 0006 A	- Housing, painted sheet steel - Power supply bracket - Sheet steel front panel with plastic cover - Accessories pack with installation material
MPH 0010 A	- Housing, painted sheet steel
EPH 0012 A	- Housing, painted sheet steel
PSF 0002 A	- Housing, painted sheet steel - Power supply bracket - Cable set for battery connection
PMF 0004 A	- Housing, painted sheet steel - Power supply bracket - Cable set for battery connection
USF 0000 A	- Housing, painted sheet steel - Mounting plate

2.5 Housings for Wall Mounting



Figure 2.6: Housings for wall mounting

Wall mounting housings are screwed directly onto the wall. This reduces the installation depth by approx. 9 cm, although the smaller 12 V/28 Ah batteries must be used as a result. The modular system makes it easy to extend the system.

Housing Designs and Combinations

Two wall mounting housings are available as a base unit:

- HCP 0006 A (for 6 modules), and
- HBC 0010 A (for 10 modules)

These housings can accommodate a panel controller with operating and display unit as the central element.

The HCP 0006 A and HBC 0010 A basic housings can be extended to meet individual requirements using:

- HBE 0012 A Modular Extension Housing for an additional 12 modules, and 2 x 12 V/28 Ah batteries
- PSS 0002 A or PSB 0004 A Power Supply housings for additional power supply units and 12 V/28 Ah batteries

Equipment Limits

The table below shows the maximum number of:

- Modules
- Panel rails (short PRS-0002-C, long PRD 0004 A)

Housing type	Modules	Short rail	Long rail
HCP 0006 A	6	1	1
HBC 0010 A	10	1	2
HBE 0012 A	12	-	3
PSS 0002 A	-	-	-
PSB 0004 A	-	-	-
DIB 0000 A	-	-	-

The table below shows the maximum number of:

- Panel controllers
- UPS power supply units
- Batteries

Housing type	Panel controller	UPS power supply units	Batteries
HCP 0006 A	1	1	2 x 28 Ah
HBC 0010 A	1	1	2 x 28 Ah
HBE 0012 A	-	1	2 x 28 Ah
PSS 0002 A	-	1	2 x 28 Ah
PSB 0004 A	-	1	4 x 28 Ah
DIB 0000 A	-	-	-

Installation Types

Various types of installation are possible:

- Surface mounted
- Installation in 482.6 mm (19") racks

For surface mounting, the housing is mounted directly on the wall. For installation in 482.6 mm (19") racks, the FRK 0019 A installation kit is used.

The housings have pre-formed cable bushings.

Front Doors

The housings can also be equipped with transparent front doors. The doors are made of impact-resistant plastic and are available in two sizes (each with a lock on the left or right).

Housing type	Front door, lock left side	Front door, lock right side
HCP 0006 A	FDT 0003 A	FDT 0000 A
HBC 0010 A	FDT 0002 A	FDT 0001 A
HBE 0012 A	FDT 0002 A	FDT 0001 A

The technical data for the housings can be found in *Housings for Wall Mounting, page 146*.

2.6

System Overview

The following figure shows a typical fire detection system design.

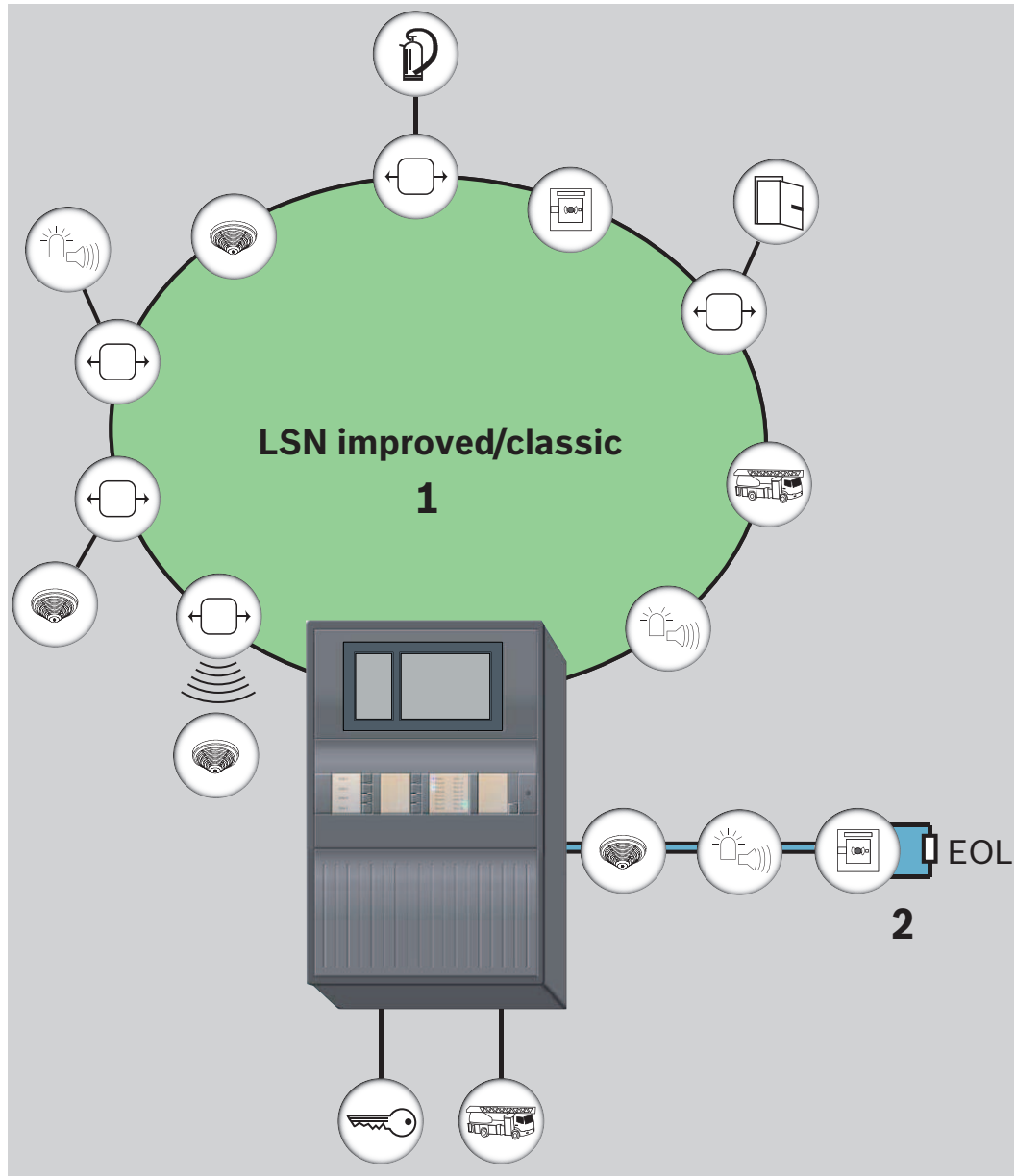



Figure 2.7: System overview with periphery

Position	Description
1	LSN loop (classic or improved version)
2	Conventional stub with EOL resistor or EOL module (optional: conventional loop)

The tables below list the various product groups with all compatible peripheral devices. The devices approved for connection to the CZM 0004 A Conventional Module or the FLM-420/4-CON Conventional Interface Module can be found in the relevant compatibility lists:

Module/interface module	Compatibility list
CZM 0004 A	F.01U.164.327
FLM-420/4-CON	F.01U.079.455

The current versions of the compatibility lists are available at www.boschsecurity.com.

Product group	Product name	LSN 0300 A / LSN 1500 A		CZM 0004 A	FLM-420/4-CO N	FK 100 LSN
		improved	classic			
Automatic fire detectors 	Point detectors					
	FAP-420/FAH-420	•	•			
	AVENAR detector 4000	•	•			
	FAP-520	•	•			
	FCP-500			•	•	
	FCP-320/FCH-320			•	•	
	DO1101A-Ex				• ¹⁾	
	RF smoke detectors					
	DOW 1171					•
	FWI-270	•	•			
	Aspirating smoke detector					
	FAS-420-TM	•	•			
	FAS-420-TP/-TT	•	•			
	Linear smoke detectors					
	Fireray 50/100RV			•	•	
	FIRERAY3000			•	•	
	FIRERAY5000			•	•	
	Linear heat detectors					
	FCS-LWM-1			•	•	
	ADW 511A				•	
	N4387A			•	•	
	Infrared flame detectors					
	DF1192				•	
	DF1101A-Ex				• ¹⁾	
	016519			•	•	
	016589			•	•	
	Duct smoke detectors					
	FAD-420-HS-EN	•	•			
	1) Connection via DCA1192/SB3 only					

Product group	Product name	LSN 0300 A / LSN 1500 A		CZM 0004 A	FLM-420/4-CO N	FK 100 LSN
		improved	classic			
Manual call points 	FMC-420RW	•	•			
	FMC-210-DM	•	•			
	FMC-210-SM	•	•			
	FMC-300RW			•	•	
	FMC-120-DKM			•	•	
	SMF 121					•
	DKM 2014/2-ex				• ¹⁾	
	DM 1103 B-Ex				• ¹⁾	
1) Connection via DCA1192/SB3 only						



Product group	Product name	LSN 0300 A / LSN 1500 A		FLM-420- NAC/ NZM 0002 A	FLM-420/4-CO N/ CZM 0004 A	RMH 0002 A
		improved	classic			
Notification appliances 	Audible notification appliances					
	MSS 300-SA/WS- EC			•		
	MSS 300-WS			•	•	
	MSS 400 LSN		•			
	MSS 401 LSN		•			
	FNM-320			•		
	FNM-320V-A-RD/ WH / -B-RD			•		
	ROLP-W-LX/ROLP- R-LX			•		
	FNM-420-A/-B/-A- BS	•	•			
	FNM-420U-A	•	•			
	FNM-420V-A	•	•			
	DS 10			•		
	HPW 11					•
	Visual notification appliances					
	FNS-320			•		
	FNS-P400RTH					•
	FNS-420-R	•	•			
	SOL-LX			•		

Product group	Product name	LSN 0300 A / LSN 1500 A	
		improved	classic
Interface modules 	FLM-420/4-CON	•	•
	FLM-420-NAC	•	•
	FLM-I 420-S	•	•
	FLM-420-RHV	•	•
	FLM-420-RLV1	•	•
	FLM-420-RLV8-S	•	•
	FLM-420-I8R1-S	•	•
	FLM-420-I2	•	•
	FLM-420-O2	•	•
	FLM-420-O8I2-S	•	•
	FLM-420-O1I1	•	•
	FLM-420-RLE-S	•	•
	FK 100 LSN		•

Product group	Product name	Connection via
Fire service devices 	FBF 100 LSN	LSN classic
	FAT 2002 FAT 2002 RE (+ ADP-NB ²)	<ul style="list-style-type: none"> - IOS 0020 A + IOP 0008 A - IOS 0020 A + FLM-420-I2 - IOS 0020 A + FLM-420-I8R1 - IOS 0020 A + FLM-420-O1I1 - IOS 0020 A + FLM-420-O8I2 - IOS 0020 A + panel controller
	FMF-FAT/FMF-FBF-FAT	FMF-ADP-TTY
	FMF-FIBS-A4/FMF-FIBS-A3	FMF-ADP-TTY
	FMF-ESPA	<ul style="list-style-type: none"> - FMF-ADP-TTY - FMF-FAT/FMF-FBF-FAT - FMF-FIBS-A4/FMF-FIBS-A3
	2) Included in the scope of delivery of the FAT 2002 RE	

Product group	Product name	Connection via
Transmission devices	AT3000 IP/GSM AT3000 IP/GSM/Analog AT3000 IP/GSM/ISDN	ENO 0000 B
	AT5000 IP/GPRS	ENO 0000 B

Product group	Product name	Connection via
Key deposits	FMS-KR-BASIC FMS-KR-BASIC-RPF	ENO 0000 B

Product group	Product name	Connection via
		
Product group	Product name	Connection via
	Automatic fire detectors	FAA-MSR 420
	FMD-GT60 FMD-GT50 FMD-GT50-SPACE	FLM-420-RHV
	TSZ 0400	FLM-420-I2

2.7 Networking



Notice!

You will find detailed information about the CAN and Ethernet networking of the panels in the Networking Guide available for download at www.boschsecurity.com

2.8 Connection to BIS

The MPC Panel Controller can be connected to a building management system (BIS) via an Ethernet connection and an OPC server.

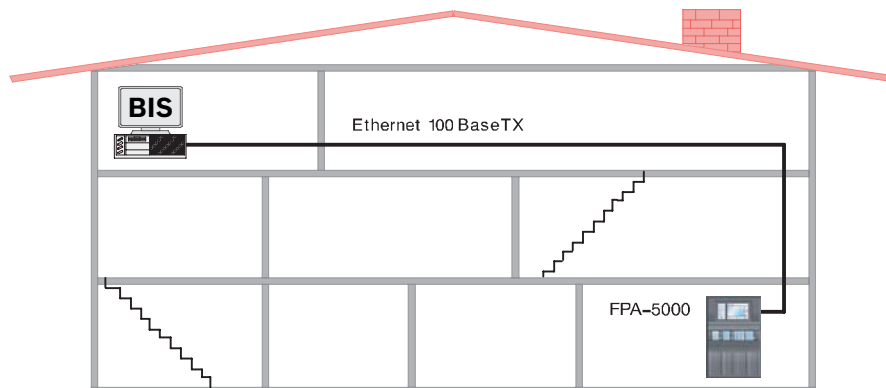

Figure 2.8: Connection to BIS

For a multiple-building network, it is essential to clarify with the network administrator:

- whether the network is designed for multiple-building connections (e.g. there must be no technical interference due to differences in grounding potential)
- whether the bus users are designed for this kind of network (e.g. sufficient bandwidth).



Notice!

For detailed information about the installation und configuration of the OPC server see the FSM-5000-OPC-Server manual.

2.9 Connecting a Voice Alarm System

The Praesideo, PAVIRO or Plena voice alarm system can be connected via a data transmission line to the panel. This enables the panel to control voice alarm zones. The control can be defined down to the individual detector level.

- For connection to the Praesideo or PAVIRO systems the Ethernet interface and IP protocols are used. The voice alarm system can be configured for up to 244 virtual VAS triggers. You will find detailed information in the Networking Guide which is available for download at www.boschsecurity.com.
- For connection to a Plena system the RS232 interface on the IOS 0020 A or IOS 0232 A is used. The Plena system can be configured for up to 120 virtual VAS triggers. You will find detailed information in the Wiring Guide which can be found on the extranet.

The virtual VAS triggers are programmed using the FSP-5000-RPS programming software.

3 Planning



Notice!

Safety Systems Designer can be used to plan fire alarm systems that conform to the relevant limits (e.g. in terms of cable length, power supply and energy requirement).

3.1 General Information

- Country-specific standards and guidelines must be considered during planning.
- The regulations issued by regional authorities and institutions (e.g. fire service) must be adhered to.
- Please note that standards and guidelines may require that a maximum of one function in more than one zone may fail.
For example, if the auxiliary power fails, only the fire detectors and/or manual call points of one zone may fail.
- We recommend the use of loops wherever possible, as they offer far greater security than stub lines.
- Terminating each stub and each T-tap with EOL modules is essential to set up a complete fire alarm system with extended line monitoring (creeping short circuit and creeping open monitoring).
- Conventional detectors of the Bosch portfolio for fire products can be connected using one of the following methods:
 - Using the CZM 0004 A 4 Zone Conventional Module
The module provides four DC primary lines (zones).
 - Using an FLM-420/4-CON GLT interface module on the LSN bus for two zones
- Consider the system limit for the number of LSN elements.
- Each element and input which is able to set off an alarm requires a detection point. Inputs are considered as detection points if they are programmed accordingly using the FSP-5000-RPS Programming Software.
- In accordance with EN 54-2, no more than 512 detectors and their functions may fail if a system component fails.
- 12 V/45 Ah batteries can only be used with the frame installation housings.
- Use fuses complying with national regulations to protect the power lines.
- Recommended fire detector cable: J-Y(St)Y 2 x 2 x 0,8 mm, red.

LSN Modules

- It is possible to combine LSN interface modules, LSN detectors and notification appliances on one loop or stub line.
- For a mixed connection of LSN classic elements and LSN improved elements, a maximum of 127 elements are permitted.
- The use of unshielded cables is possible.

- Limits per LSN 0300 module:
 - Up to 127 LSN classic elements or 254 LSN improved elements can be connected
 - Current consumption of up to 300 mA
 - Cable length of up to 1600 m
- Limits per LSN 1500 module:
 - Up to 127 LSN classic elements or 254 LSN improved elements can be connected
 - Up to 1500 mA current consumption if LSN improved elements are connected
 - Up to 300 mA current consumption if LSN classic elements are connected
 - Cable length of up to 3000 m
- As stipulated by EN 54-2, panels with more than 512 LSN elements must be equipped with a redundant panel controller.

Refer to

- *Detection Points, page 29*
- *Redundancy, page 34*
- *Achievable Cable Length with LSN 0300 A, page 36*

3.2

Detection Points

Each element or input that can trigger an alarm counts as a detection point. One stand-alone panel manages up to 4096 detection points. A panel operated in a network is limited to 2048 points.

All elements and inputs that do not use the Input type in the Message type setting are regarded as detection points. Therefore, all elements and inputs for which one of the following settings is programmed as the Message type are regarded as detection points:

- Fire
- Internal fire
- Supervisory
- Multi-criterion
- Smoke
- Fault
- Heat
- Water

Only some of these message types are available for selection depending on the element type. The elements and inputs that can trigger an alarm include all manual and automatic detectors, as well as the modules and interface modules listed below on the basis of the available inputs.

Modules	Detection Points
CZM 0004 A	Up to 4 (1 detection point per zone)
IOP 0008 A	Up to 8 (1 detection point per monitored input)
RMH 0002 A	Up to 2
ENO 0000 B	requires 1 detection point only if a FSE release element is connected and programmed using the FSP-5000-RPS programming software
FPP-5000-TI	2

Interface Modules	Detection Points
FLM-420/4CON	Up to 2

FLM-420-I8R1	Up to 8
FLM-420-I2	Up to 2
FLM-420-O8I2	Up to 2
FLM-420-O1I1	Up to 1
FLM-420-RHV	Up to 2
FLM-420-RLE-S	Up to 2

3.3 Address Setting

LSN elements are addressed via rotary switches (e.g. FAP 425-O-R) or DIP switches (e.g. E/W versions of the FLM-420). For setting addresses with DIP switches, refer to the instructions in the installation guide supplied with the product.

Address setting with rotary switches

The rotary switches can be used to select automatic or manual address setting with or without automatic detection:

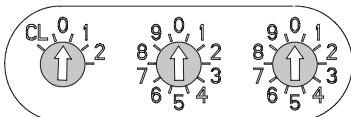
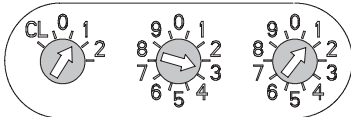
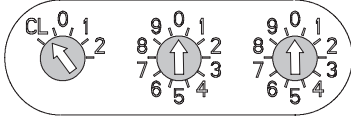
Rotary switch setting	Address	Operating mode
	0 0 0	Loop/stub in LSN improved version mode with automatic addressing (T-tapping not possible) = factory default setting
	0 0 1 ... 2 5 4	Loop/stub/T-tapping in LSN improved version mode with manual addressing (address shown in example = 131)
	CL 0 0	Loop/stub in LSN classic mode with automatic addressing (T-tapping not possible, maximum number of elements = 127)

Tab. 3.1: Address setting with rotary switches

The rotary switches are moved to the required position using a slotted-head screwdriver.

Automatic Address Setting

If addresses are automatically allocated by a fire panel (LSN improved), all elements must have the address 0 0 0 (factory default setting).

Manual Address Setting

With manual address setting, the address is set using the three rotary switches. The right-hand rotary switch is used to set the units, the central rotary switch is used to set the tens and the left-hand rotary switch is used to set the hundreds.

Manual address setting is required for T-tap topologies.

No matter what topology you set up: If you decide on manual address setting, then you have to select T-tap in FSP-5000-RPS.



Notice!

Using addresses greater than 254 is not permitted.
 With manual address setting, all the detectors in a loop, stub or T-tap must have an address between 1 and 254.

3.4 Topologies in Local Security Network

LSN classic

In a Local Security Network (LSN classic), LSN elements can be configured as a loop or as one or two stubs. An LSN classic network allows a maximum of 127 elements.

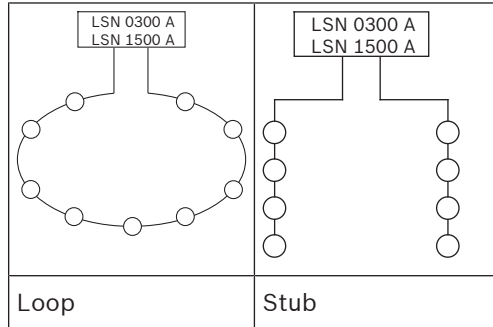

Tab. 3.2: Topologies in LSN classic

LSN improved

An LSN improved network allows a maximum of 254 elements. With automatic address setting, LSN elements can be configured as a loop or as one or two stubs. With manual address setting, not only loop or stub, but also T-tap topologies are possible. As long as the maximum number of 254 elements is not exceeded, the LSN improved network allows branches anywhere along the LSN line, with any number of nodes, any number of branches per node and any number of elements per branch. Consider, that mesh structures are not allowed.

Topologies in LSN improved with automatic address setting

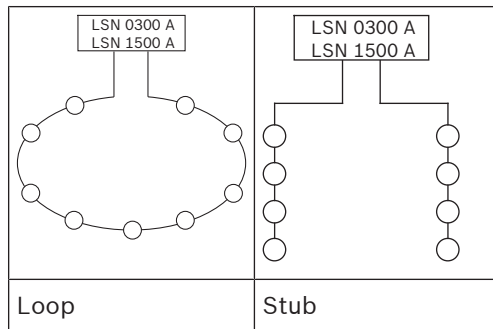

Tab. 3.3: Topologies in LSN improved with automatic address setting

Topologies in LSN improved with manual address setting (T-tap)

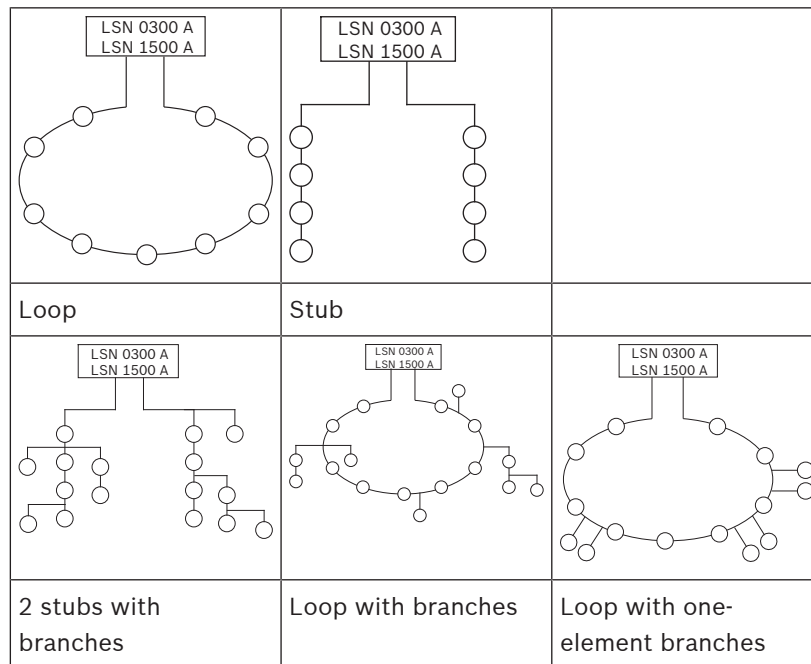

Tab. 3.4: Topologies in LSN improved with manual address setting (T-tap)

Loop topology

Each LSN element provides a built-in isolator between the b1 and b2 connectors. The current flows through the LSN element between b1 and b2. With the return of the current to the LSN module the loop is formed. In normal operation, an LSN loop is powered alternately from one or the other side (LSN1/LSN2) of the loop, and direction of the current flow changes each 10 seconds.

Stub topology

Each LSN element provides a built-in isolator between the b1 and b2 connectors. The current flows through the LSN element between b1 and b2. Therefore, the last element of the stub has only incoming but no outgoing cable. Unlike for the loop topology, the direction of the current flow remains the same.

T-tap topology

In a T-tap topology one or several branches exist anywhere along the LSN line.



Notice!

- From LSN module software version 1.0.35 onward, you can operate LSN improved elements and LSN classic elements in combination in a loop or in a stub.
- If an LSN classic element is present, only 127 elements can be used in the loop.
- T-tap topologies are only possible if only LSN improved elements are used. As soon as an LSN classic device is in a loop or stub, T-taps are no longer possible.



Notice!

In case of a bus fault, on stubs and branches no alternative way exists to reach an LSN element. Since in a loop topology each element can be reached on an alternative way for failure handling, prefer the loop topology.

Consider that regional authorities may require an upper limit to the number of elements that can be lost due to a single fault.

It is essential to ensure that no mesh structures are created.

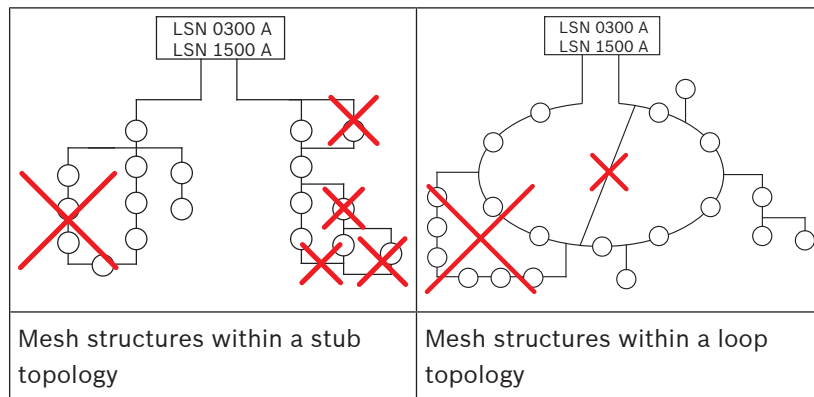

Tab. 3.5: Examples for not allowed T-tap topologies



Notice!

Planning should take the anticipated total current and line resistance into account to ensure each detector has an operating voltage of at least 15 V DC.

3.5

Failure handling in Local Security Network

In case of a short circuit condition or an open condition, a loop topology offers for each unaffected LSN element an alternative way to keep up its application functionality. The LSN loop will be split. One resulting stub is powered by LSN1, the other resulting stub is powered by LSN2. The LSN line and the affected elements are in trouble status. An automatic reinitialization starts.

Unlike for the loop topology, you will lose all application functionality behind the element with short circuit or open condition in case of a stub or a branch.

Consider that the isolation function is limited if you use single-element branches on the LSN line. In a single-element branch the isolator function of the LSN element is not used: The b wires of the LSN line are only connected to one of the b connectors of the devices, e. g. b1. The LSN element will be powered through the b1 connector, and the current powering the remaining line is not passing through the element. The element thus does not act as an isolator. Each two neighboring isolating elements define a zone, and all elements within the zone will be affected in case of a short circuit fault within the zone. A short circuit will interrupt the application functionality in the zone.

Regional authorities may require an upper limit to the number of elements that can be lost due to a single fault. This limits the number of non-isolating elements that can be placed between two isolating elements.

Removal of LSN element

The removal of an LSN element also results in an open condition. During reinitialization the application functionality of all elements is interrupted. Therefore, the automatic reinitialization can affect the alarm timing of the devices.

Detector removal feature in T-tap topology

This feature ensures detector removal without affecting the alarm timing of other devices. The feature is based on prevention of reinitialization due to detector removal. The feature is available with LSN bus module firmware 1.0.55 and higher. In regions where local applicable standards require this feature, proceed as follows:

- Detectors whose removal should not affect the alarm timing of other devices must be installed as the last elements of T-tap stubs: Connect both the incoming and outgoing LSN b line to the b1 connector or connect both to the b2 connector. This will prevent a loop interruption when the element is removed. Since, it also prevents the element to act as an isolator, isolation must be ensured by the isolator in one of the other elements on the loop. In case of a short circuit condition, all non-isolated elements between the two isolating elements will be disconnected. The number of non-isolating elements between two isolating elements must thus be limited in number according to local regulations.
- Additionally, activate in FSP-5000-RPS under **Network Settings** the feature **Detector Removal Feature in T-Tap**.

Previously removed detectors can be reinserted back into their bases. After a reset of the LSN line the detectors will be restored to their normal function.



Notice!

The Detector removal feature in T-tap topology should only be used if required by regional authorities.

If the independence of the alarm timing is not required, then use all isolators to reduce the number of detectors affected by a short circuit.

3.6

Redundancy

Standards and guidelines (e.g. DIN VDE 0833-2, EN 54-2) require different, country-specific redundancy conditions for specific applications:

- In the event of a system fault in the panel or the system, no more than 512 detectors may fail (EN 54-2). In such cases, redundant system components must be used:
 - Redundant panel controller
 - Redundant connection to a Bosch UGM
 - Redundant connection of the transmission device or AT5000 IP/GPRS. Refer to the Wiring guide, which can be found on the extranet (access rights required).
- Activation of extinguishing systems in accordance with VdS 2496: If a signal processing unit fails, no more than one extinguishing area may fail. In such cases, redundant system components must be used:
 - Redundant panel controller
 - Redundant LSN 0300 A module when using more than one FLM-420-RLE-S in an LSN loop

Redundant panel controller

For a redundant connection, a second basic housing with an additional panel controller and a CRP 0000 A Cable Set is required, where applicable. The figure below shows a configuration with a redundant panel controller. The slots **(2)** behind a redundant panel controller **(1)** must not be occupied with modules.

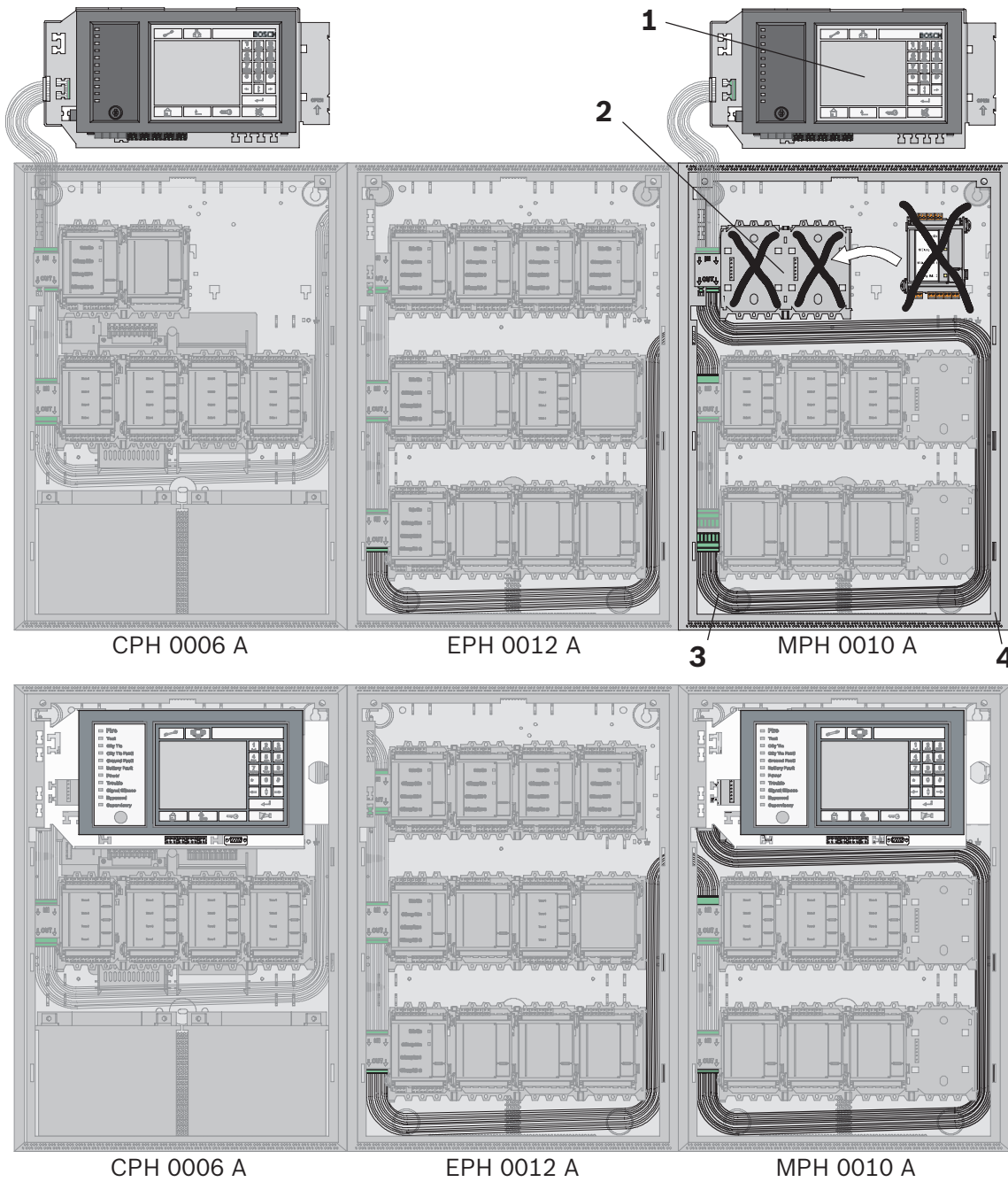

Figure 3.1: Redundant configuration

Pos.	Designation	Description
1	MPC	Redundant panel controller
2	PRS-0002-C	Short panel rail (may not be occupied with modules)
3	CRP 0000 A	Redundant MPC cable set
4	CPH 0006 A or MPH 0010 A	Redundant panel housing, additionally installed PRD 0004 A Panel Rail Long (1 x in the CPH 0006 A or 2 x in the MPH 0010 A) may be fitted with modules.

For installation reasons, only 42 modules can be programmed when configuring a redundant panel. Without redundancy, 46 modules per panel are possible if one housing is set up with the panel controller and 10 modules and three housings each with 12 modules.



Notice!

In line with EN 54-2, a redundant panel controller must be used if there are more than 512 detectors connected.

3.7

Achievable Cable Length with LSN 0300 A

The usable cable length depends essentially on the resistance of the cable and the quantity and current consumption of the network elements. The way in which the elements are distributed locally on the bus also makes a difference.

The possible cable length can be estimated using the formula below. This formula is also used in the Safety Systems Designer and is based on the critical application situation where all network elements are concentrated at the end of the bus line. The calculated cable lengths are therefore on the conservative side. The diagrams on *Using the Diagram for LSN classic, page 36* and *Using the Diagram for LSN classic, page 36* can be used to make a quick estimate.

$$q \times \frac{[U_0 - U_{END} - n_E \times R_{FET} \times (n_E/2 \times I_{NE} + I_{trans} + I_{flash}) + 1/2 \times R_{FET} \times (I_{trans} + I_{flash})]}{2 \times \rho \times (n_E \times I_{NE} + I_{trans} + I_{flash})}$$

The following applies:

L = cable length to be calculated in [m]

U₀ = bus voltage at the connection terminals = 30 volt

U_{End} = bus end voltage = 15 volt (must not fall below this limit!)

q = cable cross section = 0.503 mm² (for cable Ø 0.8 mm)

n_E = number of elements

ρ = specific resistance of copper = 0.0178 Ω mm²/m

R_{FET} = FET resistance = 0.7 Ω (LSN classic) or 0.35 Ω (LSN improved),

I_{NE} = average current consumption of elements in [A]

I_{trans} = transmission current = 0.012 A

I_{flash} = flash current = 0.018 A

Note that the sum of non-isolated cables must not exceed the limit of 500 m. The limit of 500 m applies to:

- The lines on the inputs of the following modules: FLM-420-RHV, FLM-420-I2 , FLM-420-I8R1-S, FLM-420-O8I2-S, FLM-420-O1I1, FLM-420-RLE-S
- The NAC line of the FLM-420-NAC module
- The lines to remote indicators: FAA-420-RI-DIN, FAA-420-RI-ROW

The limit of 500 m non-isolated cables doesn't count for the conventional lines of the FLM-420/4-CON and the lines connected to the relay contacts and open collector outputs.

Note that the maximum cable length must not exceed 1600 m.

Using the Diagram for LSN classic

FET resistance = 0.7 Ω, fire alarm cable with Ø 0.8 mm

Example 1:

You want to know the maximum cable length for a given number of network elements and a given current consumption (n_E = 50, I_{NE} = 3 mA). On the X axis, go vertically up at 50 until you reach the 3 mA curve. Then, from the point of intersection go horizontally to the left to the Y axis and read off the maximum achievable cable length. In this example it is 840 m.

Example 2:

You want to know the maximum number of network elements for a given cable length and an average current consumption of the network elements ($L = 1000 \text{ m}$, $I_{NE} = 20 \text{ mA}$). Starting from the Y axis at 1000, go horizontally across to the right as far as the 20 mA curve and then from the point of intersection vertically down to the X axis. Read off the maximum number of network elements, in this example it is 8.



Notice!

Remote indicators activated by the detector C point:

A maximum additional cable length of 500 m is allowed when using remote indicators (e.g. FAA-420-RI-DIN/FAA-420-RI-ROW). The total length of installed cable must not exceed the limit of 1600 m.

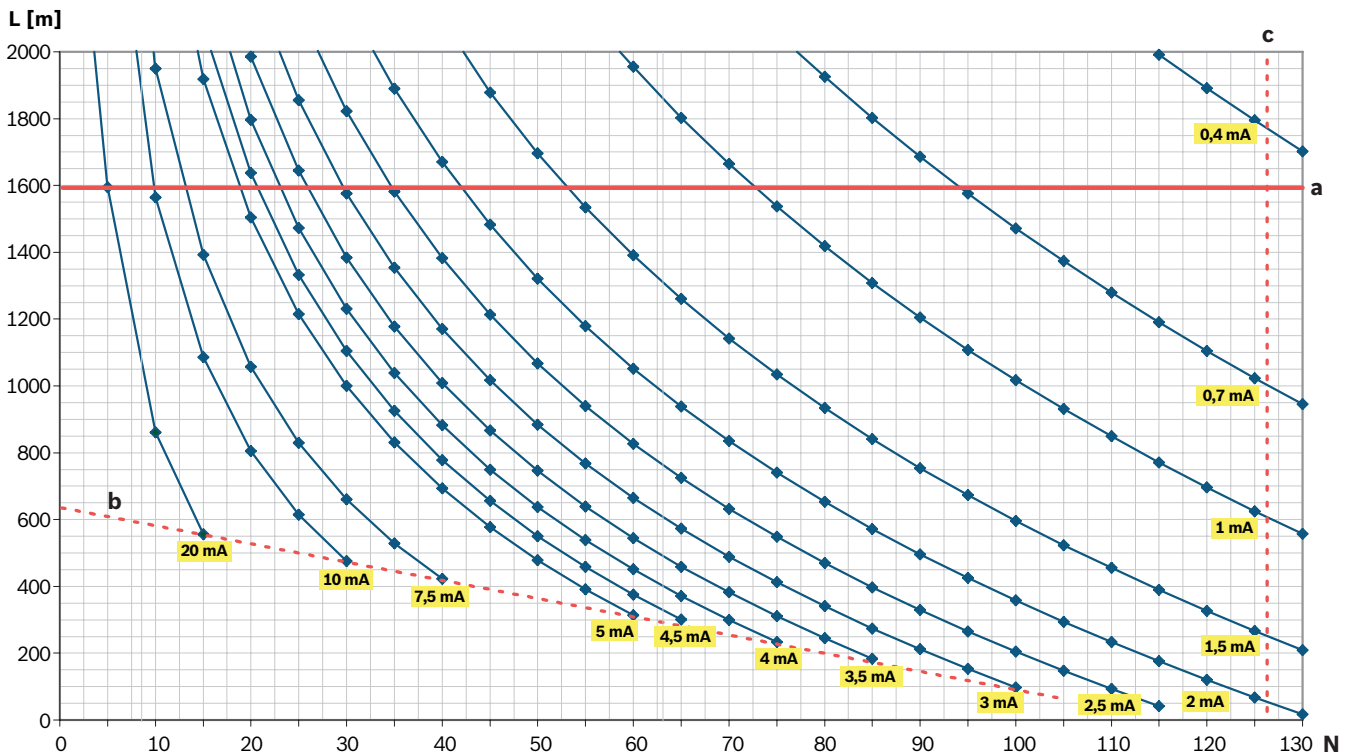

Figure 3.2: Diagram for determining the maximum achievable cable length: LSN classic elements with LSN 0300 A

- L = cable length in meters
- N = number of LSN classic elements
- a = 1600 m limit
- b = 300 mA limit
- c = maximum possible number of LSN classic elements = 127

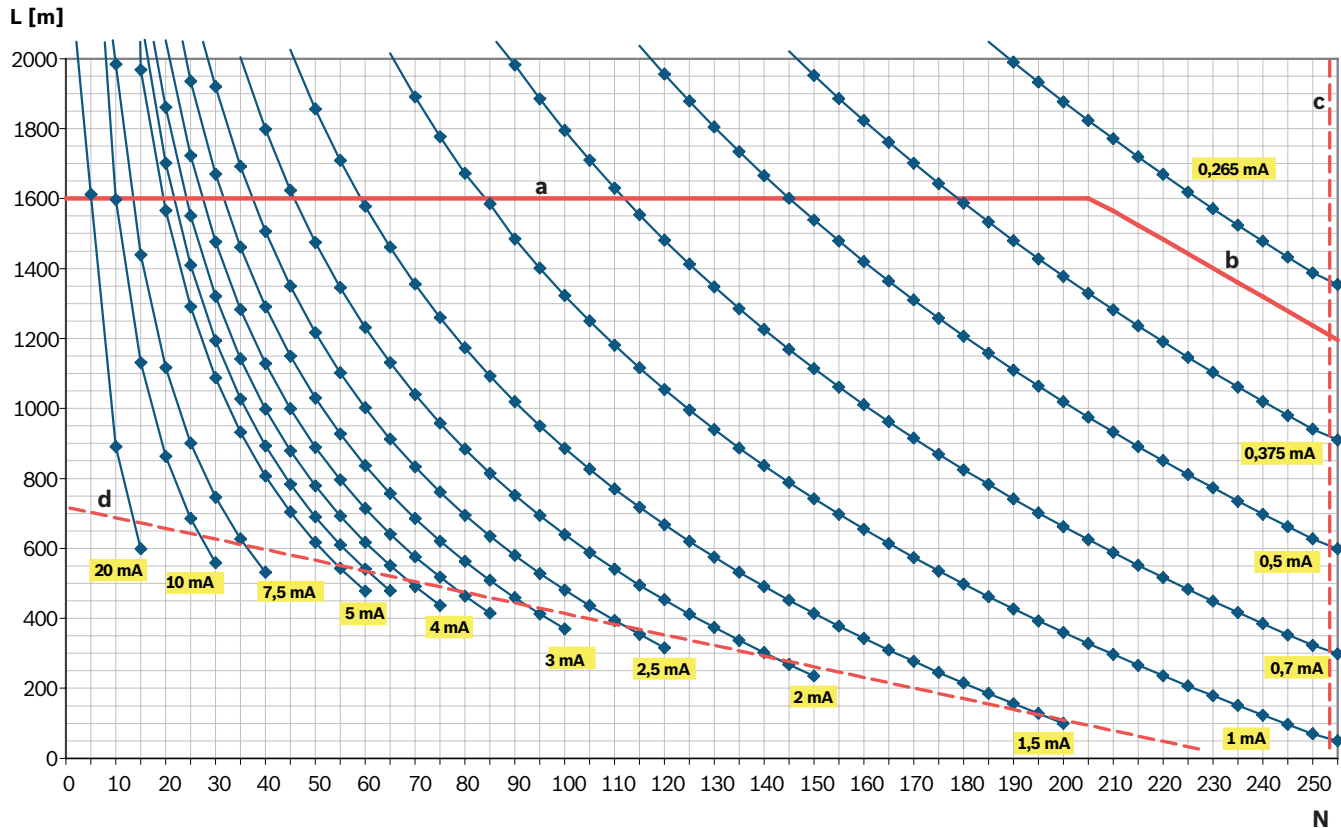

Figure 3.3: Diagram for determining the maximum achievable cable length: LSN improved elements with LSN 0300 A

- L = cable length in meters
- N = number of LSN improved elements
- a = 1600 m limit
- b = bus dynamic limit
- c = maximum possible number of LSN improved elements = 254
- d = 300 mA limit

3.8 Achievable Cable Length with LSN 1500 A

The usable cable length depends essentially on the resistance of the cable and the quantity and current consumption of the network elements.

The way in which the elements are distributed locally on the bus also makes a difference. The possible cable length can be estimated using the formula below. This formula is also used in the Safety Systems Designer and is based on the critical application situation where all network elements are concentrated at the end of the bus line. The calculated cable lengths are therefore on the conservative side.

The diagrams on pages *Using the Diagram for LSN improved, page 39* and *Using the Diagram for LSN improved, page 39* can be used to make a quick estimate.

$$L = \frac{q \times [U_0 - U_{END} - n_E \times R_{FET} \times (\frac{n_E}{2} \times I_{NE} + I_{trans} + I_{flash}) + \frac{1}{2} \times R_{FET} \times (I_{trans} + I_{flash})]}{2 \times \rho \times (n_E \times I_{NE} + I_{trans} + I_{flash})}$$

The following applies:

- L = cable length to be calculated in [m]
- U₀ = bus voltage at the connection terminals = 30 volt

U_{End} = bus end voltage = 15 volt (must not fall below this limit!)
 q = cable cross section = 0.503 mm^2 (for cable $\varnothing 0.8 \text{ mm}$)
 n_E = number of elements
 ρ = specific resistance of copper = $0.0178 \text{ mm}^2/\text{m}$
 R_{FET} = FET resistance = 0.7Ω (LSN classic) or 0.35Ω (LSN improved),
 I_{NE} = average current consumption of elements in [A]
 I_{trans} = transmission current = 0.012 A
 I_{flash} = flash current = 0.018 A

Note that the sum of non-isolated cables must not exceed the limit of 500 m. The limit of 500 m applies to:

- The lines on the inputs of the following modules: FLM-420-RHV, FLM-420-I2 , FLM-420-I8R1-S, FLM-420-O8I2-S, FLM-420-O1I1, FLM-420-RLE-S
- The NAC line of the FLM-420-NAC module
- The lines to remote indicators: FAA-420-RI-DIN, FAA-420-RI-ROW

The limit of 500 m non-isolated cables doesn't count for the conventional lines of the FLM-420/4-CON and the lines connected to the relay contacts and open collector outputs. Note that the maximum cable length must not exceed 3000 m.

Using the Diagram for LSN improved

FET resistance = 0.35Ω , fire alarm cable with $\varnothing 0.8 \text{ mm}$

Example 1:

You want to know the maximum cable length for a given number of network elements and a given current consumption ($n_E = 120$, $I_{\text{NE}} = 0.5 \text{ mA}$). On the X axis, go vertically up at 120 until you reach the 0.5 mA curve. Then, from the point of intersection go horizontally to the left to the Y axis and read off the maximum achievable cable length. In this example it is 1950 m.

Example 2:

You want to know the maximum number of network elements for a given cable length ($L = 1000 \text{ m}$, $I_{\text{NE}} = 2 \text{ mA}$). Starting from the Y axis at 1000, go horizontally across to the right as far as the 2 mA curve and then from the point of intersection vertically down to the X axis. Read off the maximum number of network elements, in this example it is 73.



Notice!

Remote indicators activated by the detector C point:

A maximum additional cable length of 500 m is allowed when using remote indicators (e.g. FAA-420-RI-DIN/FAA-420-RI-ROW).

The total length of installed cable must not exceed the limit of 3000 m.

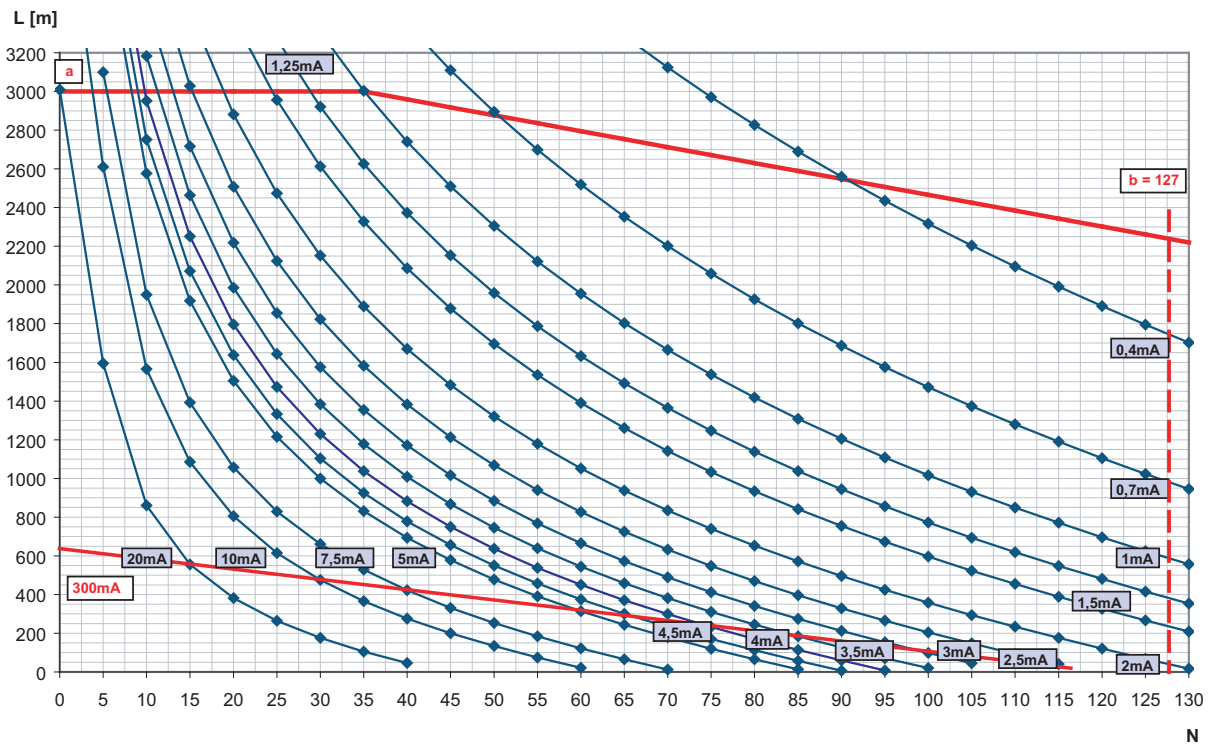

Figure 3.4: Diagram for determining the maximum achievable cable length: LSN classic elements with LSN 1500 A

- L = cable length in meters
- N = number of LSN classic elements
- a = 3000 m limit
- b = maximum possible number of LSN classic elements = 127

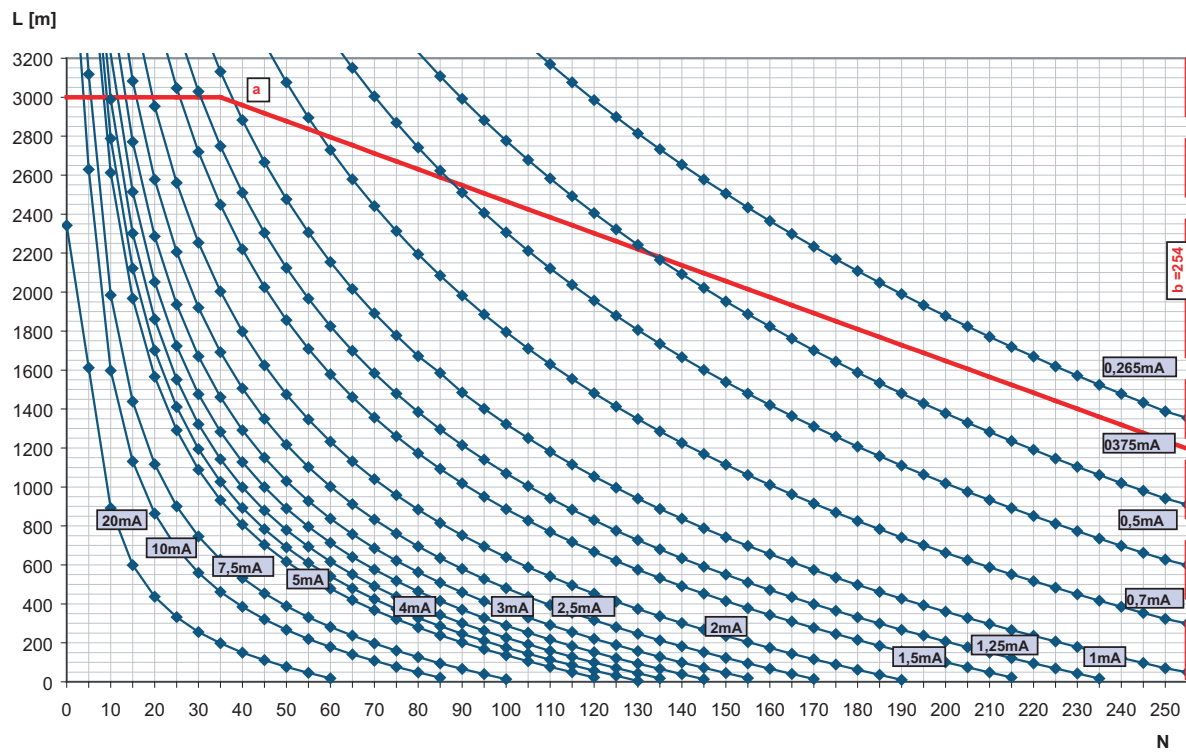

Figure 3.5: Diagram for determining the maximum achievable cable length: LSN improved elements with LSN 1500 A

L = cable length in meters

N = number of LSN improved elements

a = Bus dynamic limit

b = maximum possible number of LSN improved elements = 254

3.9 Examples of Housing Equipment

CPH 0006 A, Fully Configured Panel, with Installation Sequence

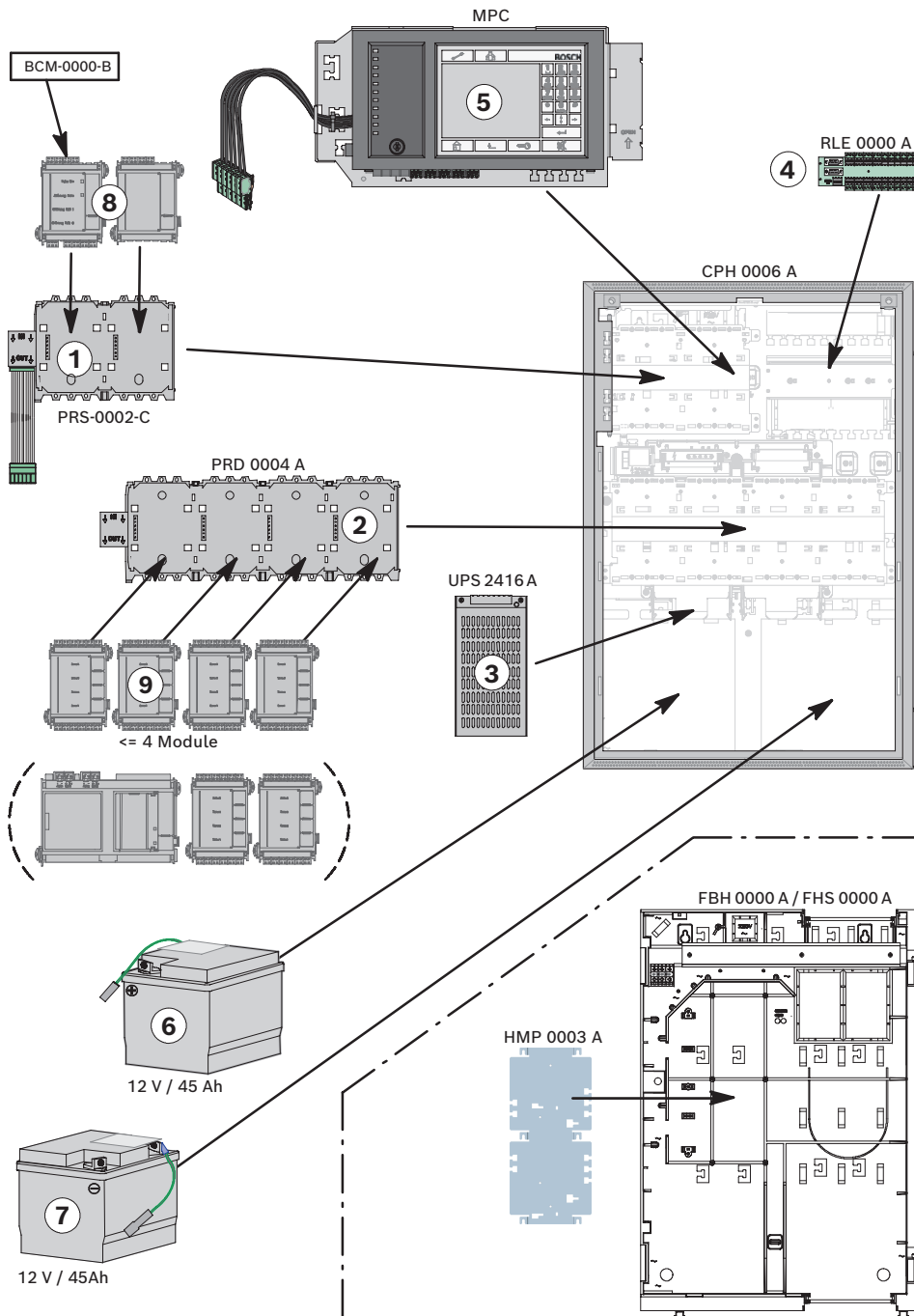

Figure 3.6: Example of configuration with CPH 0006 A frame installation housing for 6 modules

HCP 0006 A, Fully Configured Panel, with Installation Sequence

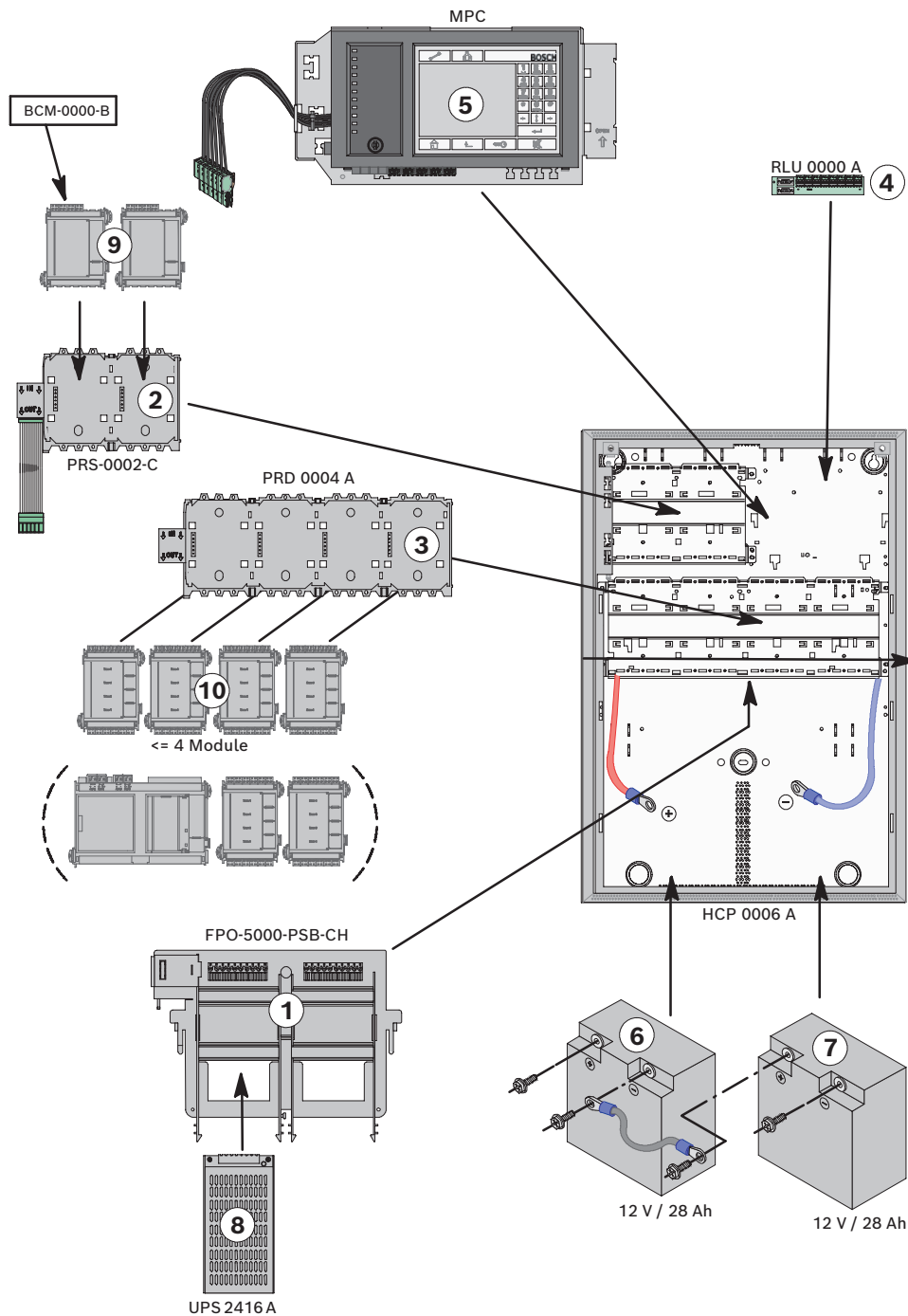

Figure 3.7: Example of configuration with HCP 0006 A Modular Panel Housing for 6 Modules

3.10 Configuration of BCM Battery Controller Module

The panel can be powered by up to 8 BCM-0000-B Battery Controller Modules, each with its own UPS 2416 A Universal Power Supply. Current consumption is equally distributed among all battery controller modules.

Notes

- The 24 V switch outputs may not be connected in parallel.
- The total current for all connected MPCs including the battery charge current may not exceed 6 A.

- The batteries connected to the BCM must all be of the same type and have identical electrical properties.
- The cable length at the switch outputs for faults may not exceed 3 meters.
- The cables for the switch outputs for faults may only be routed inside the housing.

Configuration with One to Four BCM Modules in Wall Mounting Housings

- Up to 2 BCM-0000-B modules on short panel rail
- Maximum 2 BCM-0000-B modules at the end of the long panel rail
- Each BCM-0000-B module requires one UPS 2416 A Universal Power Supply.

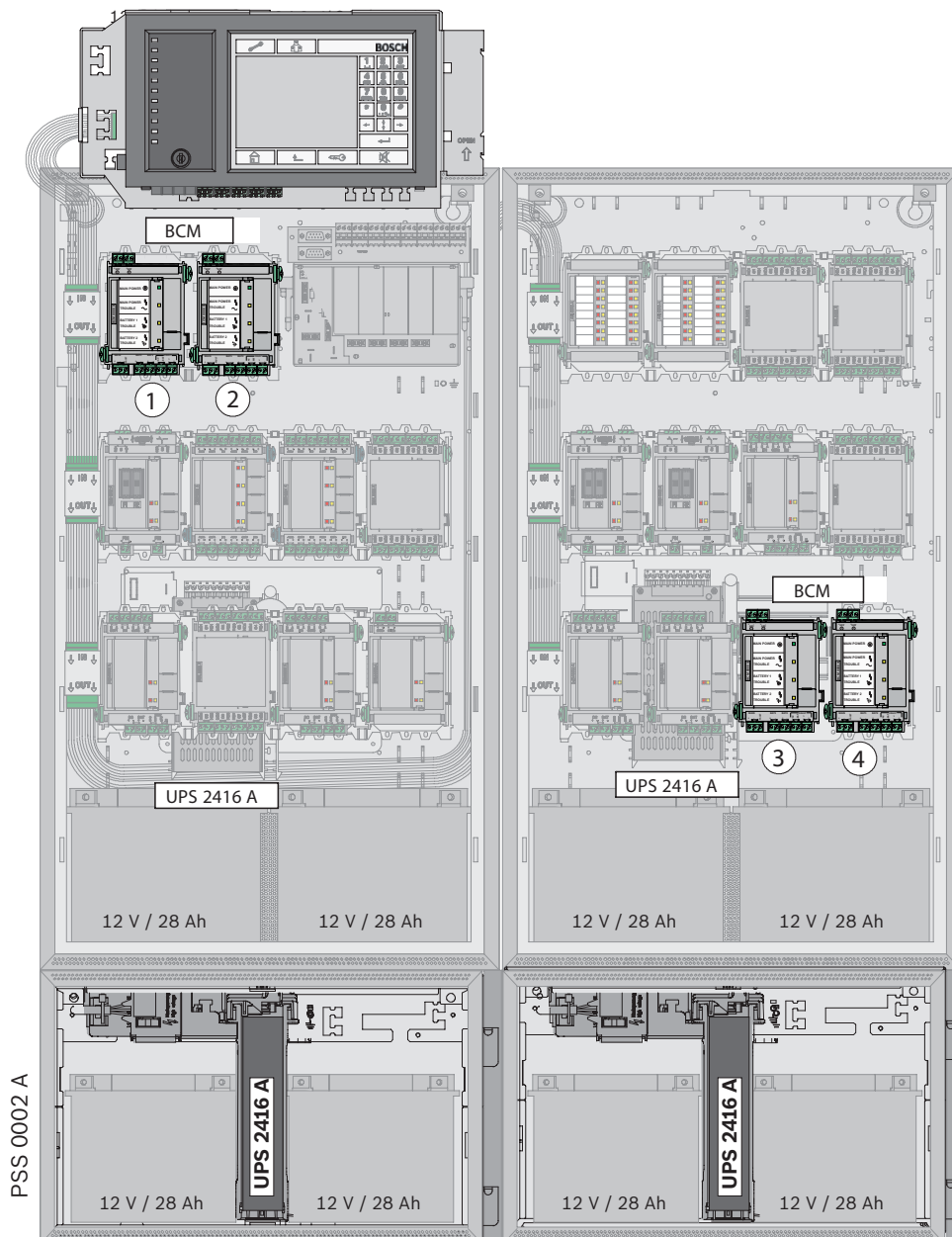

Figure 3.8: Configuration of 1 to 4 BCM modules (wall mounting)

Configuration with One to Four BCM Modules in Frame Installation Housings

- Up to 2 BCM-0000-B modules on short panel rail
- Maximum 2 BCM-0000-B modules at the end of the last long panel rail
- Each BCM-0000-B module requires one UPS 2416 A Universal Power Supply.

Depending on the back-up time, a PMF 0004 A housing may be required instead of the PSF 0002 A housing for the power supply.



Figure 3.9: Configuration of 1 to 4 BCM modules (frame installation)

Configuration with 5 to 8 BCM Modules in Wall Mounting Housings

- 2 BCM-0000-B modules on short panel rail
- 2 BCM-0000-B modules at the end of the long panel rail
- The remaining BCM-0000-B modules on a panel rail in the center of the system.
- Each BCM-0000-B module requires one UPS 2416 A Universal Power Supply.

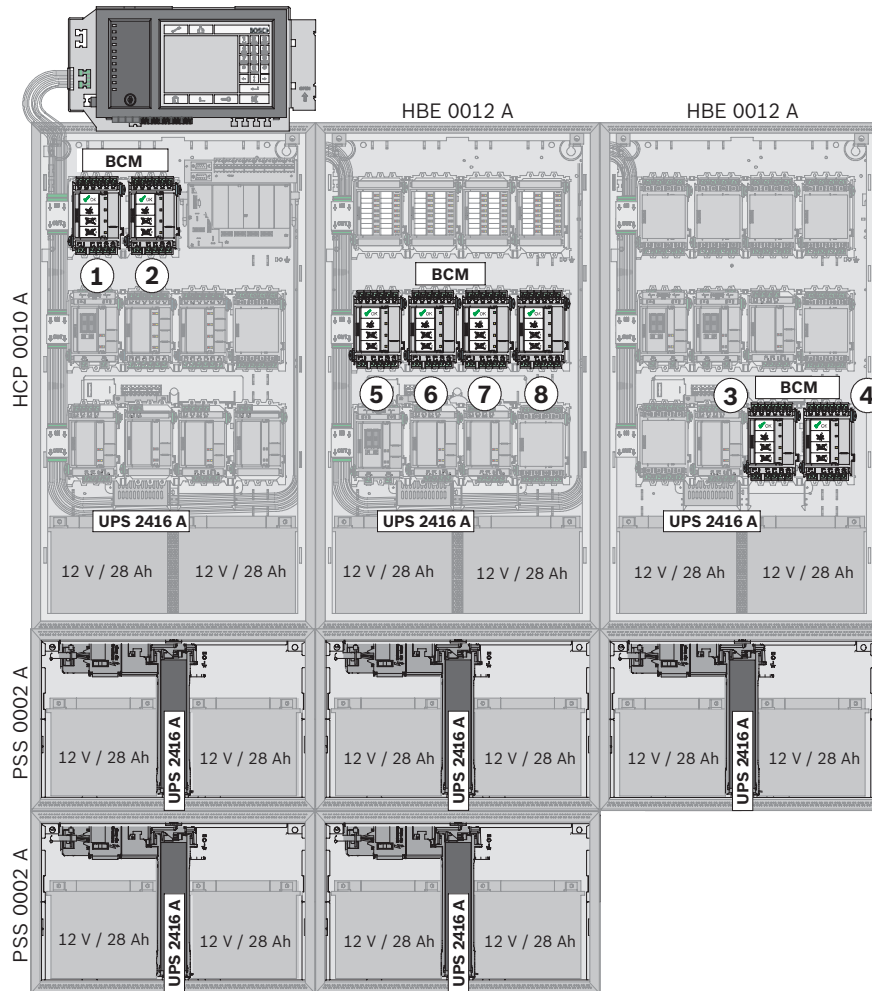

Figure 3.10: Configuration of 5 to 8 BCM modules (wall mounting)

Limits:

The current load on a panel rail may not exceed the maximum value of 12 A.

The current load via a panel rail plug may not exceed the maximum value of 10 A.

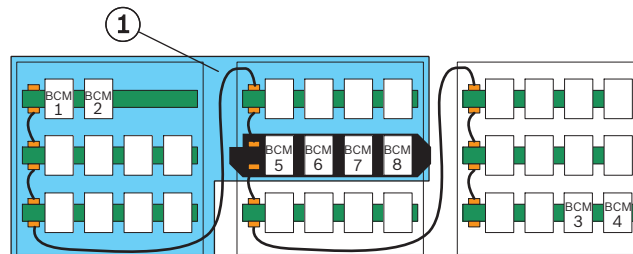

Figure 3.11: Area 1

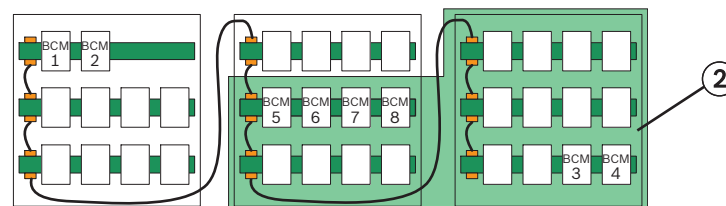

Figure 3.12: Area 2

Standby Current Calculation to EN 54-4

$$(1) I_{\max, \text{Standby}} = \frac{C_{\text{Batt}} - I_{\text{Alarm}} \times 0,5\text{h}}{t_{\text{Standby}}} \quad (2) I_{\max, A} = 6A - \frac{C_{\text{Batt}}}{18\text{h}}$$

$$(3) I_{\text{nom}} = \min[I_{\max, \text{Standby}}, I_{\max, A}]$$

Formula (1) describes the maximum system current to guarantee a particular back-up time ($I_{\max, \text{Standby}}$).

Formula (2) describes the maximum system current taking into account simultaneous battery charging ($I_{\max, A}$).

The system standby current (I_{nom}) to be selected is calculated from the lower of the two maximum system current values, as shown in the formula (3).

Parameters:

- t_{Standby} = back-up time in hours
- I_{Alarm} = maximum alarm current ($I_{\max, B}$)
- C_{Batt} = battery capacity in Ah

Possible capacities (C_{Batt}):

- 24 - 26 Ah or 36 - 45 Ah with 2 batteries
- 48 - 52 Ah or 72 - 90 Ah with 4 batteries

3.11**Protective earth and equipotential bonding**

Country-specific standards and guidelines must be considered, e.g. DIN VDE 0100-540, particularly with regard to the protective function of the electrical safety. These must be observed by qualified personnel.

- ▶ The UPS 2416 A power supply is a class I electrical appliance. Protection earth is required.
- ▶ Protective earth must be applied to the corresponding connection point of the copper rail in the mounting frame. The protective earth must have a safety connection to the electrical earth (ground). In addition to the protective function of the electrical safety, this also fulfills the functional requirements of protecting the system against interference voltages and electromagnetic disturbances.

4**Installation****4.1****General Information****Warning!**

Live components and stripped cable! Risk of injury from electric shock. The system must be current-free during connection work.

**Warning!**

Electrostatic discharge.

The standard precautions for CMOS technology must be taken when handling PC boards.

- The fire panel may only be installed and commissioned by trained specialist personnel.
- Only use installation materials recommended by Bosch. Otherwise, interference resistance cannot be guaranteed.
- Connection conditions set down by the regional authorities and institutions (police, fire service) must be observed.

Environmental Conditions

- Assembly and operation of the fire panel must be carried out in a clean and dry indoor location.
- Permissible relative humidity: max. 95 % at 25°C, non-condensing
- To ensure optimum battery service life, the panel should only be operated at sites with normal room temperatures.
- Do not operate devices showing condensation.

Positioning

- Operating and display elements should be positioned at eye level.
The distance between the upper edge of the housing and the center of the panel controller display is around 11 cm. For example, if the eye level required is 164 cm, the housing upper edge installation dimension is 175 cm.
- For frame installation housings, a clearance of at least 230 mm is required to the right of the last housing to swivel out the installed housing (e.g. for connection, maintenance or service).
- Sufficient space should be left below and next to the panel for any possible extensions, e.g. for an additional power supply or an extension housing.

**Notice!**

The maximum installation height is 2 m!

Functional Modules

- Functional modules are encapsulated; the connection terminals are protected against static discharge.

Building Management System

- If connected to a building management system (Bosch Building Integration System BIS) via an Ethernet interface using an OPC server, the following must be noted:
In a multi-building network, it is essential to clarify with the network administrator whether the network is designed for multi-building connections (e.g. no interference due to differences in grounding potential).

Documentation

- All product documentation including the operating instructions can be found on the DVD that is supplied with the panel controller.
The current and full product documentation can be found on www.boschsecurity.com.
- For those with access rights, the current wiring guide can be found on the extranet. This contains information about the wiring of the functional modules and the peripheral devices.
- A printed user guide in the relevant national language is supplied with the panel controller. Store the documents in a safe place.

4.2

Quick Installation Guide

1 Keep to hand:

- The installation instructions supplied with the relevant components (housing, frame, cables etc.)
- The required tools.

An overview of the required tools can be found in the installation instructions.

2 Preparation

- Lay the pre-cabling.
- Optional: network cabling.

3 Installation of housing

Installation of wall mounting housing

Install:

- Housing
- Optional: accessories for housing
- Power supply bracket
- Power supply unit and batteries
- Panel rail
- Panel controller
- Functional modules

Installation of frame installation housing

Install:

- Mounting frames
- Housing
- Optional: accessories for housing
- Power supply unit and batteries
- Panel rail
- Panel controller
- Functional modules

4 After installation

Store all documents.

4.3 Installation of Housing Components

Installation Instructions for Wall Mounting Housing and Mounting Frame

All listed mounting frames, wall mounting housings, and extension housings are supplied with the following installation materials:

- 3 6 x 50 mm screws
- 3 Ø 8 mm dowels

To install, proceed as follows:

1. Mark the 3 required holes on the wall as shown in the installation drawing.
2. At the marked points, drill holes approx. 55 mm deep with an 8-mm drill. Insert a dowel in each hole.
3. Screw the upper fixing screws to a distance of 5 mm from the wall and fit the housing or mounting frame.
4. Now fit the third fixing screw. This 'safety' screw prevents the housing from being pushed up and off the top screws.
5. Then check the installation position and securely tighten all screws.

Installing Several Housings

It is possible to install several housings for frame mounting directly beneath each other by connecting the frames to each other. The following instructions explain such an installation using the example of the FBH 0000 A and FSH 0000 A mounting frames.

First, install the FBH 0000 A mounting frame as explained above (steps 1-5).

1. Push the grooves of the FSH 0000 A **Mounting Frame (2)** onto the guide rails of the FBH 0000 A **Mounting Frame (1)**.

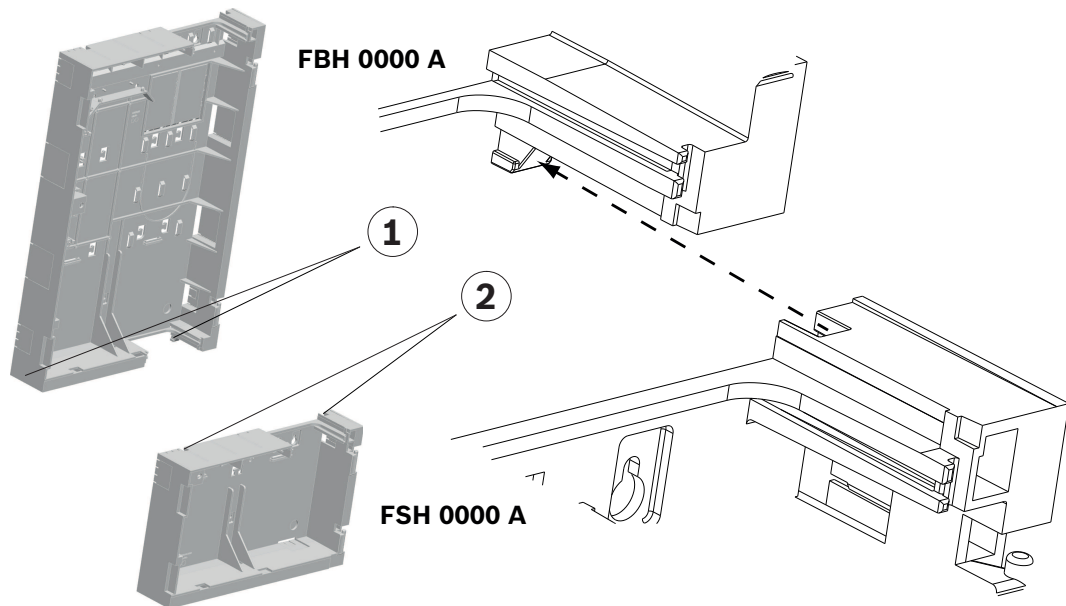

2. Mark the 3 required holes on the wall as shown in the installation drawing for the FSH 0000 A Mounting Frame (see *FSH 0000 A Mounting Frame Small, page 63*).
3. Remove the FSH 0000 A Mounting Frame.
4. At the marked points, drill holes approx. 55 mm deep with an 8-mm drill. Insert a dowel in each hole.
5. Refit the FSH 0000 A Mounting Frame, as described in step 1.
6. Screw the FSH 0000 A Mounting Frame tight.

4.3.1

Installation Instructions for Housing

All housings and housing components are supplied with installation instructions ex works. You can also find the installation instructions at www.boschsecurity.com by searching for the type designation of the product you want to install. The document numbers of the installation instructions can be found in the footer on every page of the document. The tables below show the instructions available.

Frame Mounting

Panel housings for frame installation		Document number
CPH 0006 A	Frame installation housing for 6 modules	4.998.154.002
MPH 0010 A	Frame installation housing for 10 modules	4.998.154.003
Extension housings		
EPH 0012 A	Frame installation extension housing for 12 modules	4.998.154.005
PMF 0004 A	Frame installation power supply housing	F.01U.003.083
PSF 0002 A	Frame installation power supply housing	F.01U.003.082
USF 0000 A	Universal frame installation extension housing	F.01U.003.106
Mounting frames		
FBH 0000 A	Mounting frame, large	4.998.153.998
FHS 0000 A	Mounting frame, large with distributor rail	4.998.154.018

FMH 0000 A	Mounting frame, medium	4.998.153.999
FSH 0000 A	Mounting frame, small	4.998.154.000

Installation kits

FRB 0019 A	Installation kit for frame installation housing CPH 0006 A, MPH 0010 A and EPH 0012 A	4.998.154.015
FRM 0019 A	Installation kit for PMF 0004 A power supply housing	4.998.154.017
FRS 0019 A	Installation kit for frame installation housing PSF 0002 A and USF 0000 A	F.01U.003.352

Wall Mounting

Panel housings for wall mounting		Document number
HCP 0006 A	Modular panel housing for 6 modules	4.998.153.981
HBC 0010 A	Modular panel housing for 10 modules	4.998.153.995

Extension housings

HBE 0012 A	Wall mounting extension housing for 12 modules	4.998.153.996
PSB 0004 A	Wall mounting power supply housing	4.998.154.010
PSS 0002 A	Wall mounting power supply housing	4.998.154.009
DIB 0000 A	Distribution box	F.01U.003.105

Installation kit

FRK 0019 A	Universal installation kit for all wall mounting housings	F.01U.005.045
------------	---	---------------

Front Doors

Type designation	Description	Document number
FDT 0000 A	Front door, transparent, lock right side	F.01U.003.101
FDT 0001 A	Front door, transparent, large, lock right side	F.01U.003.100
FDT 0002 A	Front door, transparent, large, lock left side	F.01U.003.104
FDT 0003 A	Front door, transparent, lock left side	F.01U.003.102

4.3.2 Installation Dimensions for Wall Mounting Housing HCP 0006 A Modular Panel Housing for 6 Modules

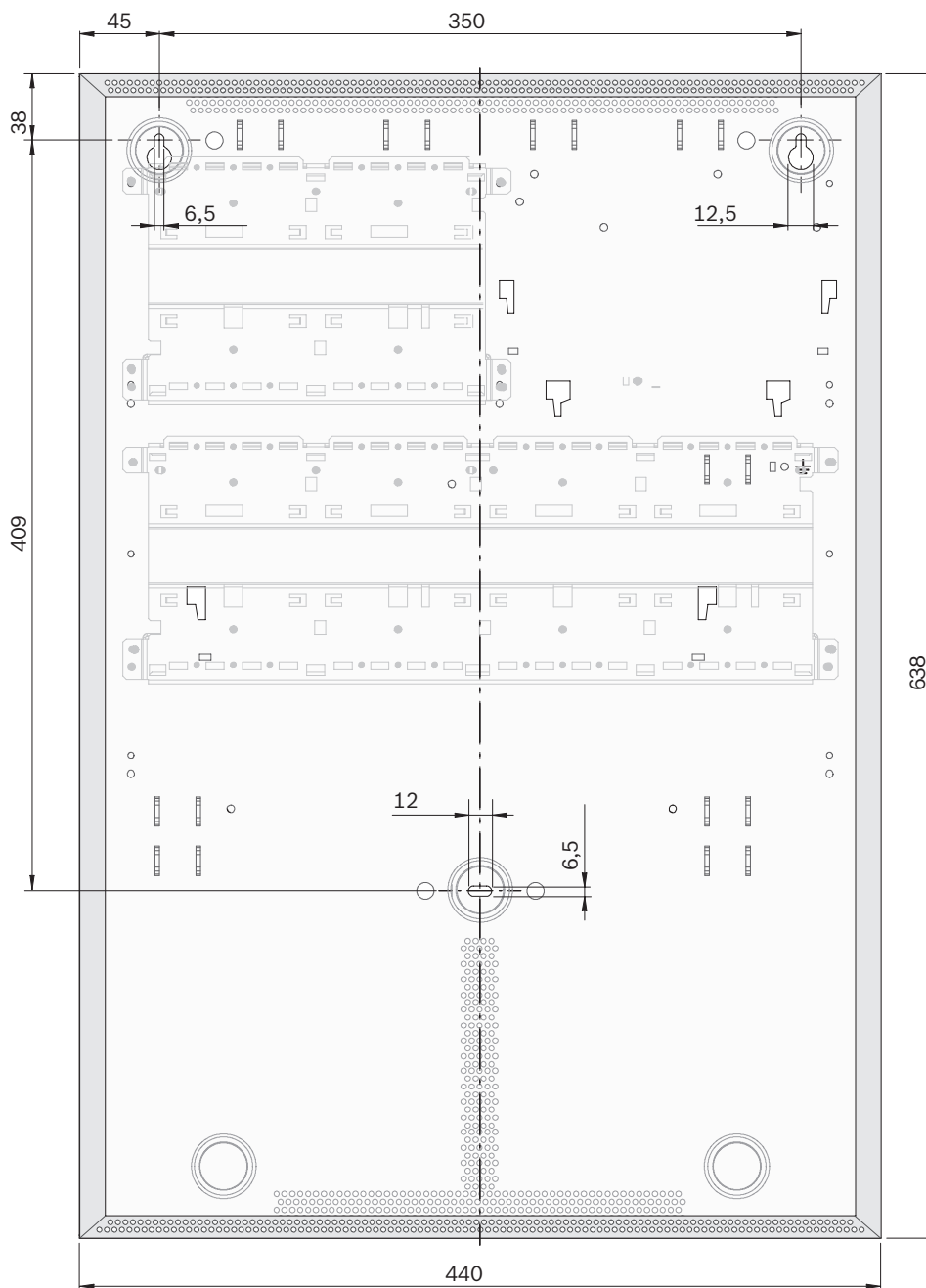

Figure 4.1: Housing: Installation dimensions - HCP 0006 A [in mm]

HBC 0010 A Modular Panel Housing for 10 Modules

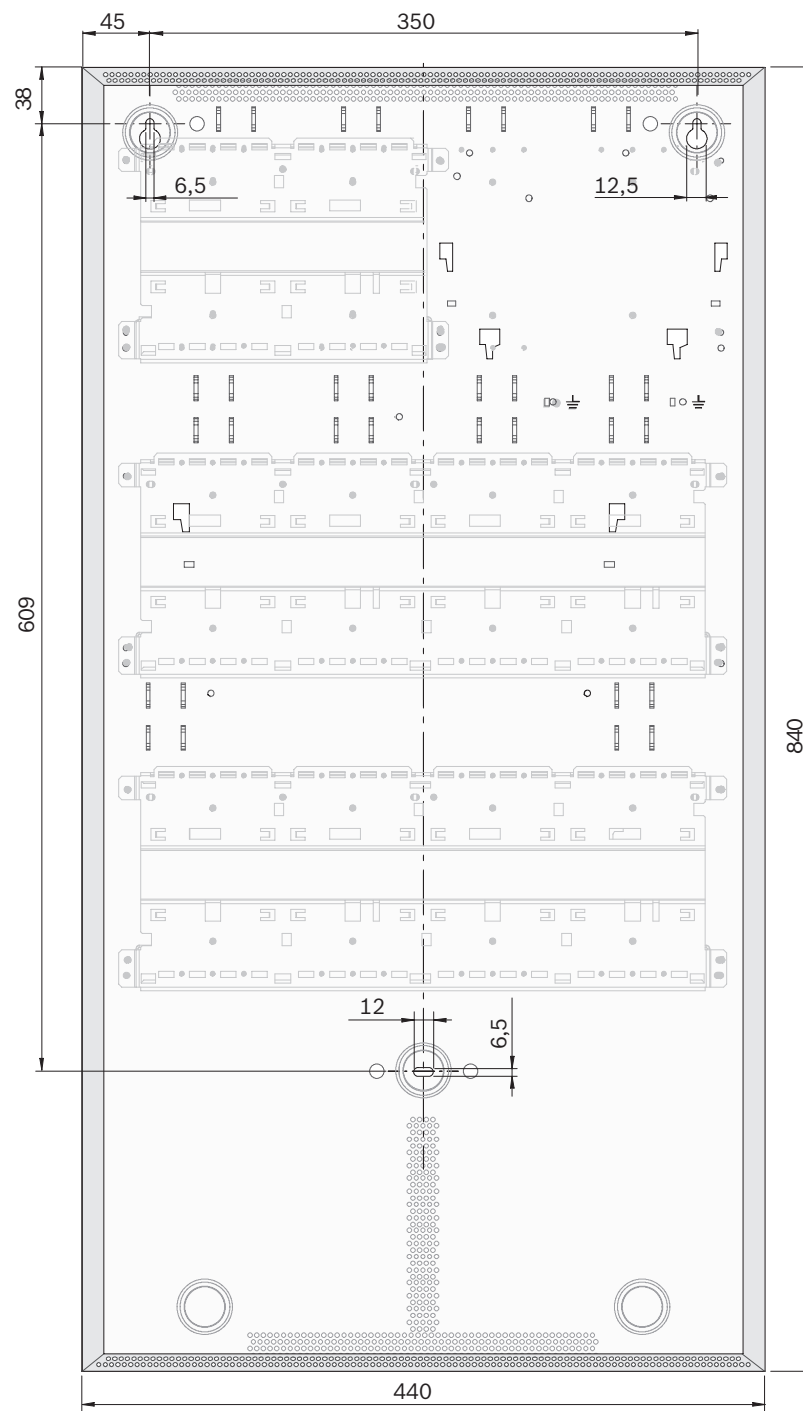

Figure 4.2: Installation dimensions - HBC 0010 A [in mm]

HBE 0012 A Modular Extension Housing for 12 Modules

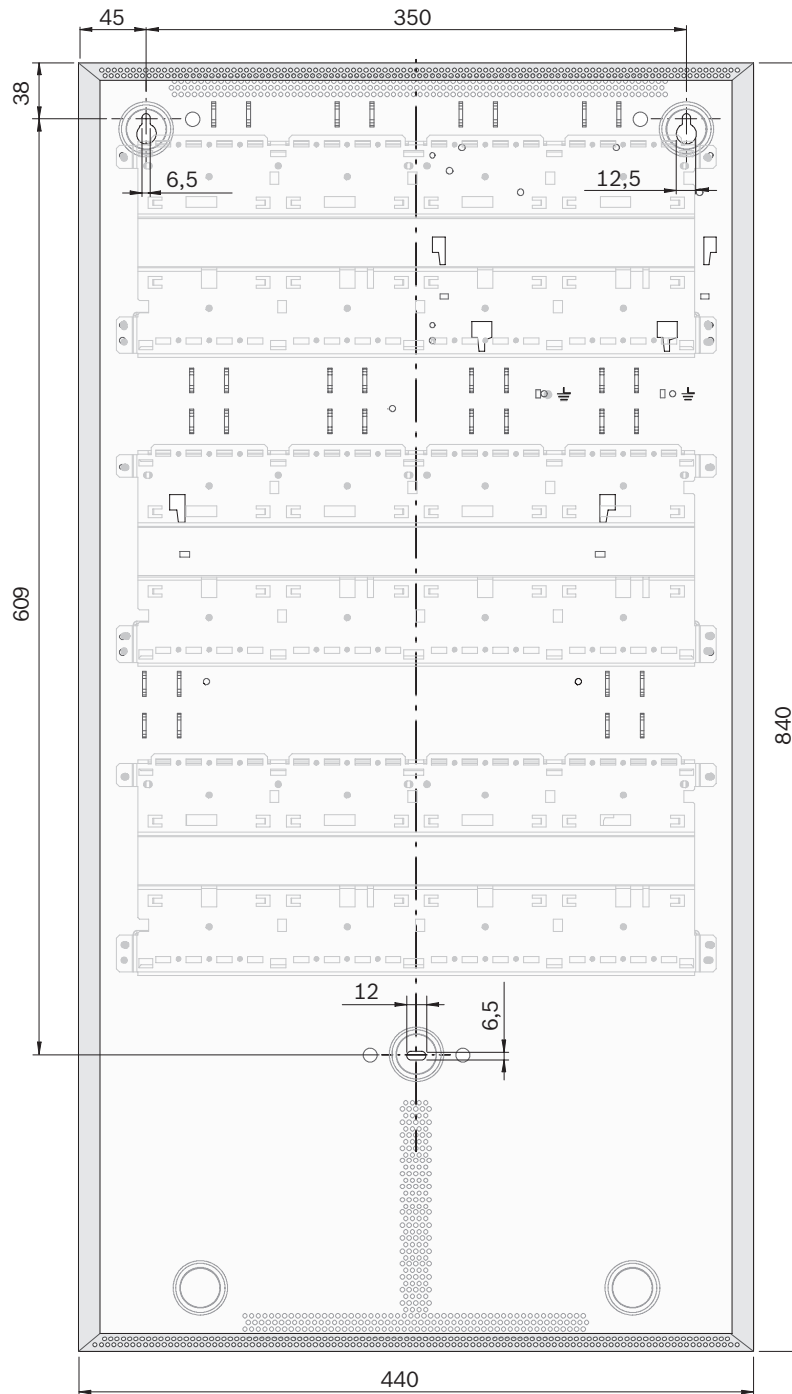

Figure 4.3: Installation dimensions - HBE 0012 A [in mm]

PSB 0004 A Power Supply Module, Wall Mounting

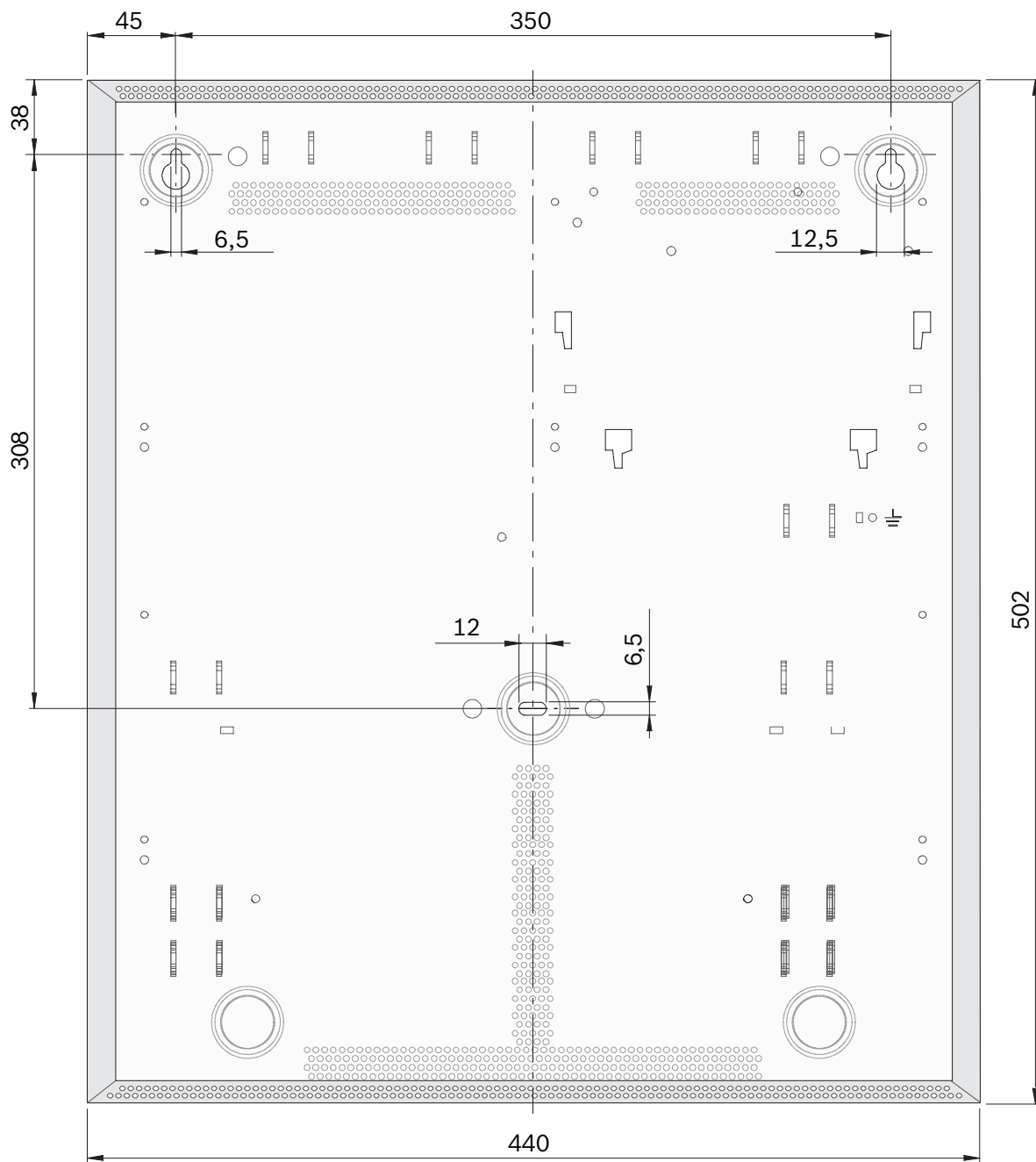

Figure 4.4: Installation dimensions - PSB 0004 A [in mm]

PSS 0002 A Power Supply Small/DIB 0000 A Distribution Box

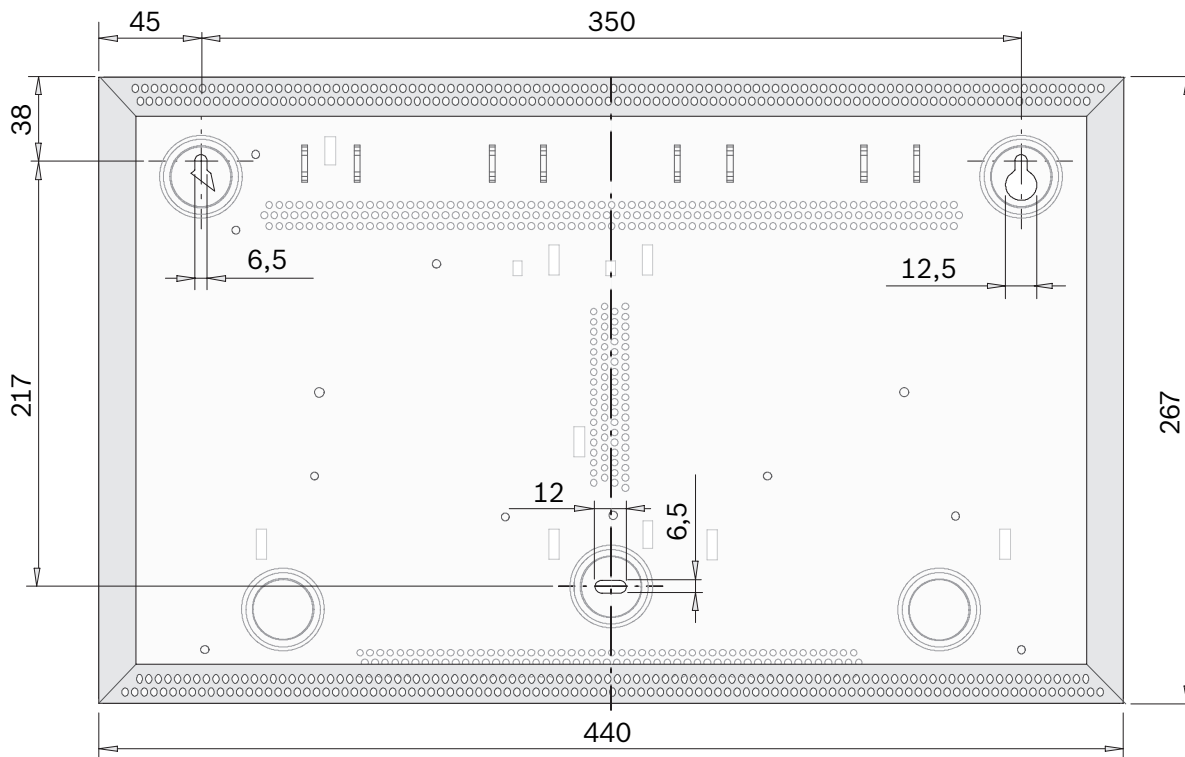

Figure 4.5: Installation dimensions - PSS 0002 A/DIB 0000 A [in mm]

Cable Bushings

Wall mounting housings have pre-punched cable bushings with the three most common diameters (22 mm, 35 mm, 44 mm).



Notice!

Carefully punch out the pre-punched hole for the cable entry and fit a suitable cable grommet. When inserting the cable into the housing, pierce a hole in the grommet with a pointed object, do not cut.

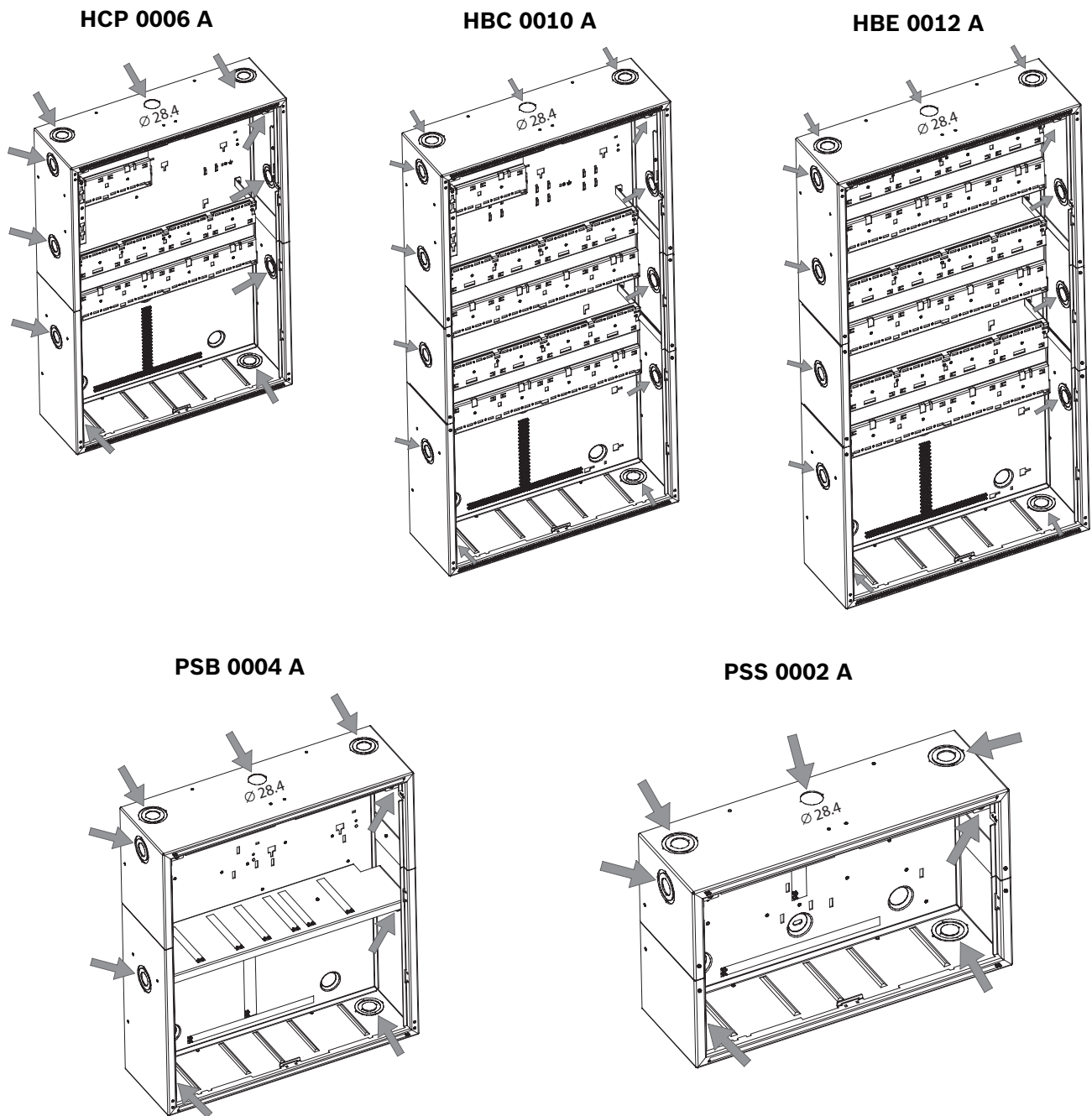

Figure 4.6: Wall mounting housing cable bushings

4.3.3 Installation Dimensions for Frame Installation Housing

Installation Dimensions for CPH 0006 A, EPH 0012 A and MPH 0010 A with FBH 0000 A or FHS 0000 A Mounting Frames

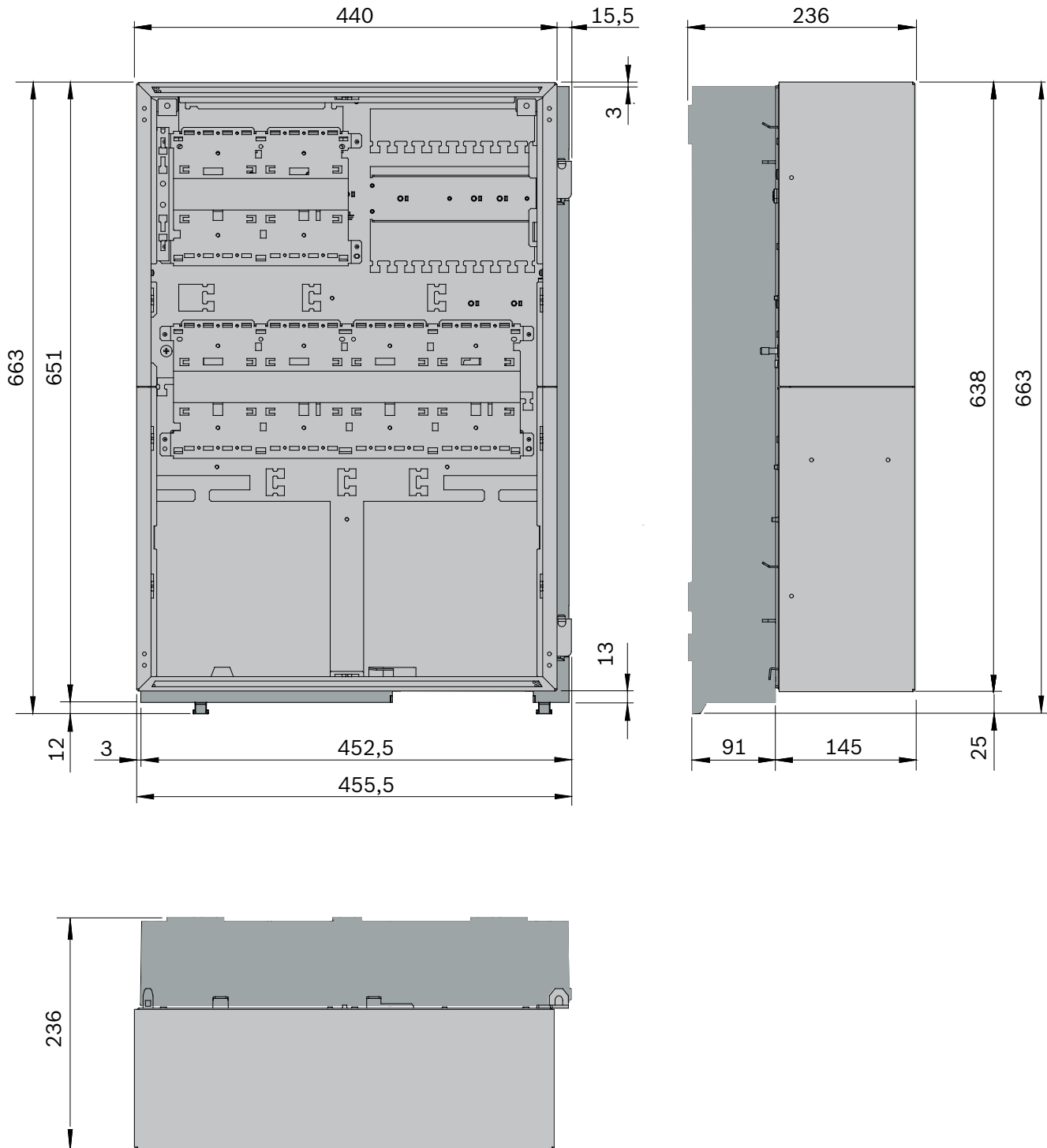

Figure 4.7: Housing: Installation dimensions Installation dimensions for CPH 0006 A, EPH 0012 A and MPH 0010 A [in mm]

Installation Dimensions for PMF 0004 A with FMH 0000 A Mounting Frame

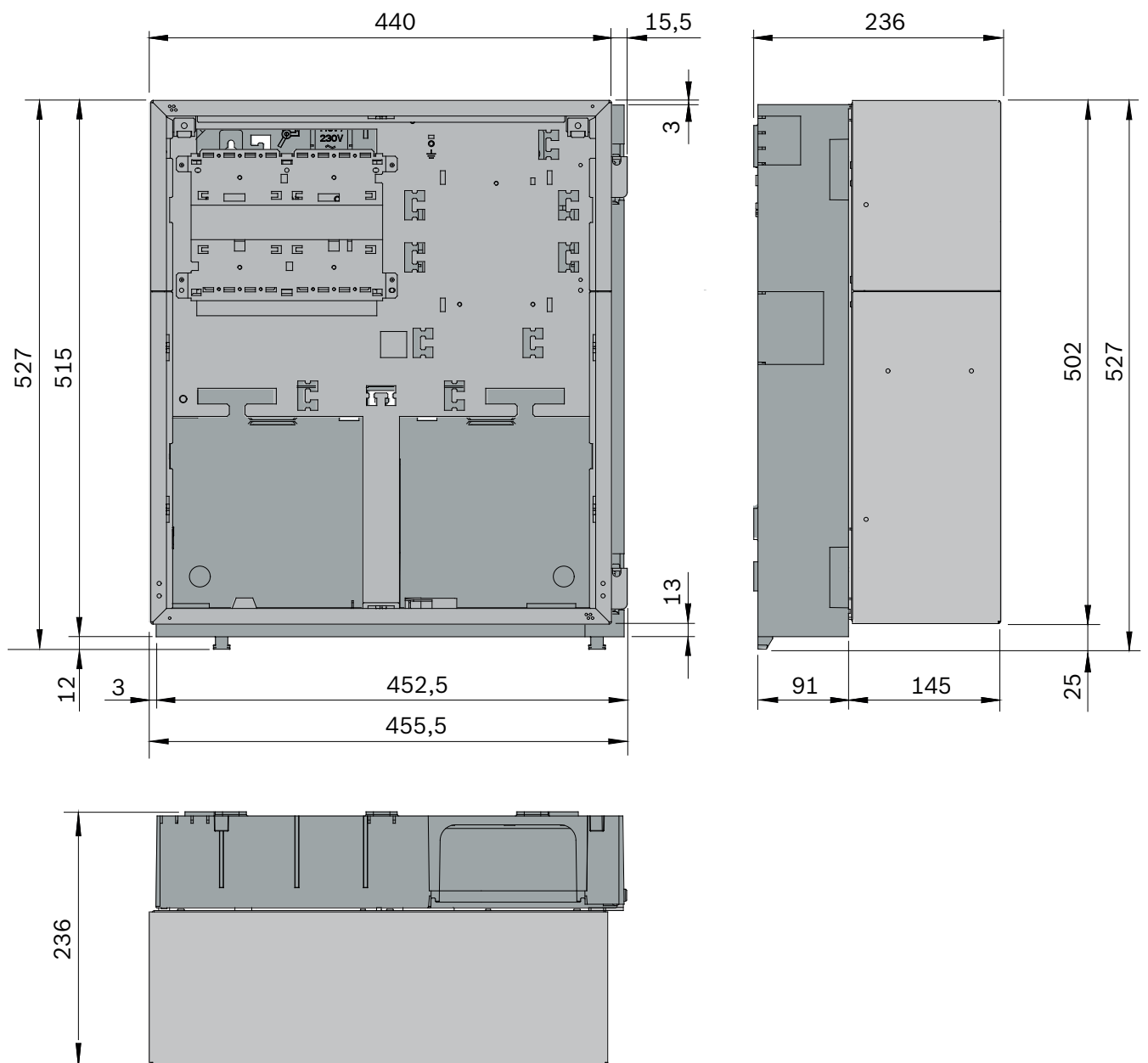

Figure 4.8: Installation dimensions for PMF 0004 A [in mm]

Installation Dimensions for PSF 0002 A and USF 0000 A with FSH 0000 A Mounting frame

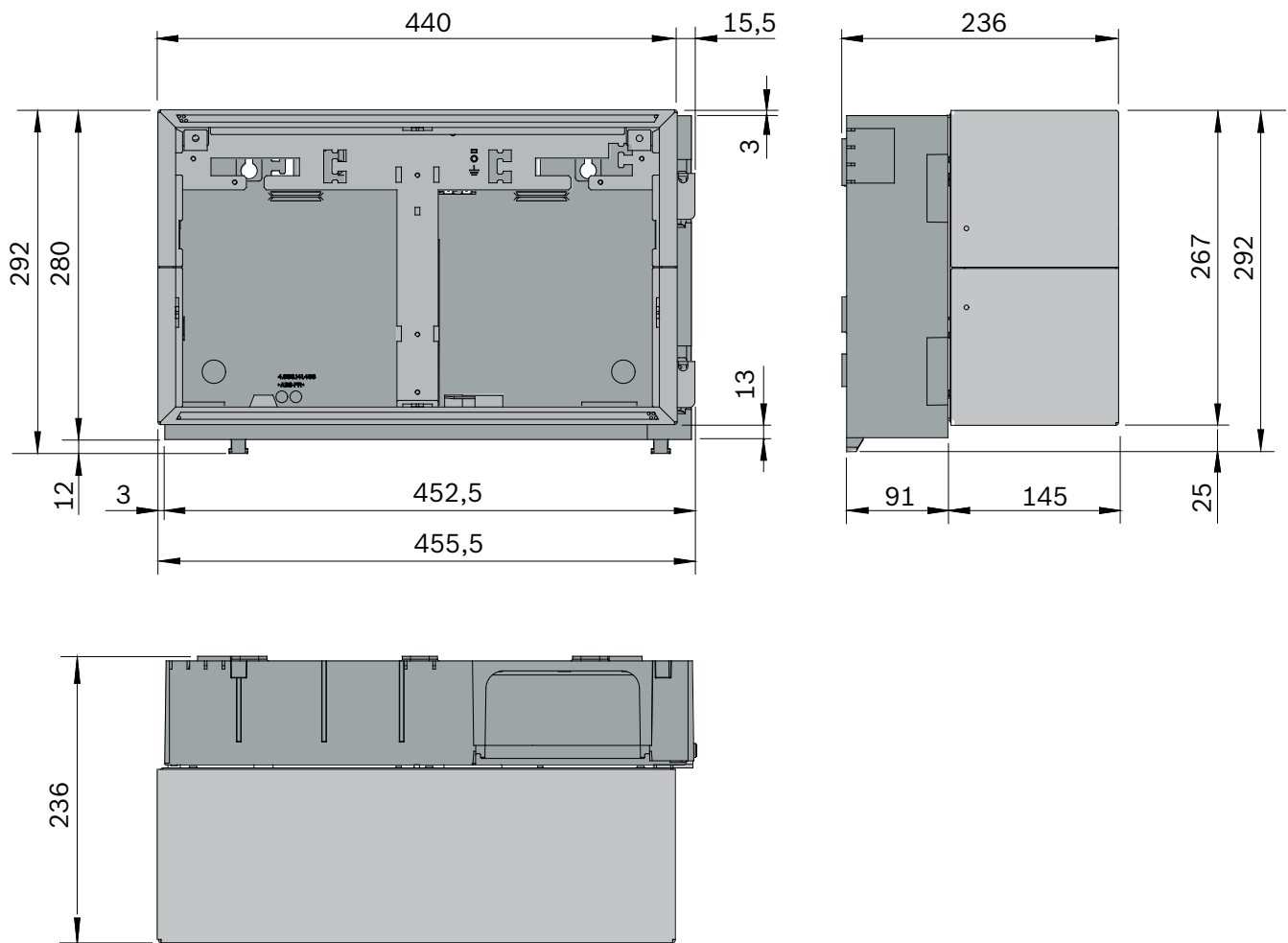

Figure 4.9: Installation dimensions for PSF 0002 A and USF 0000 A [in mm]

4.3.4 Installation Dimensions for Mounting Frames

FBH 0000 A/FHS 0000 A Mounting Frame Large

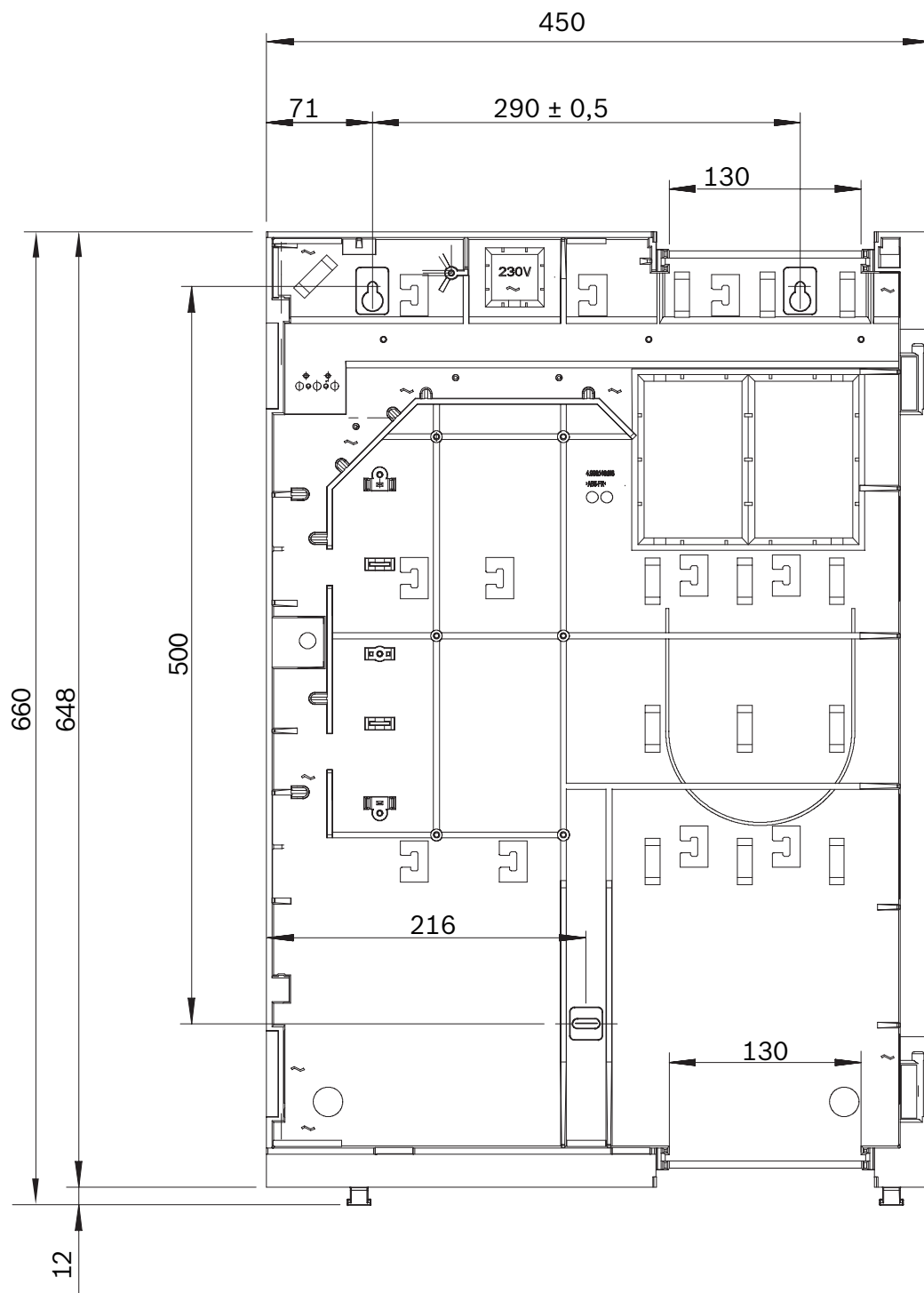

Figure 4.10: Mounting frame: Installation dimensions - FBH 0000 A/FHS 0000 A [in mm]

FMH 0000 A Mounting Frame Medium

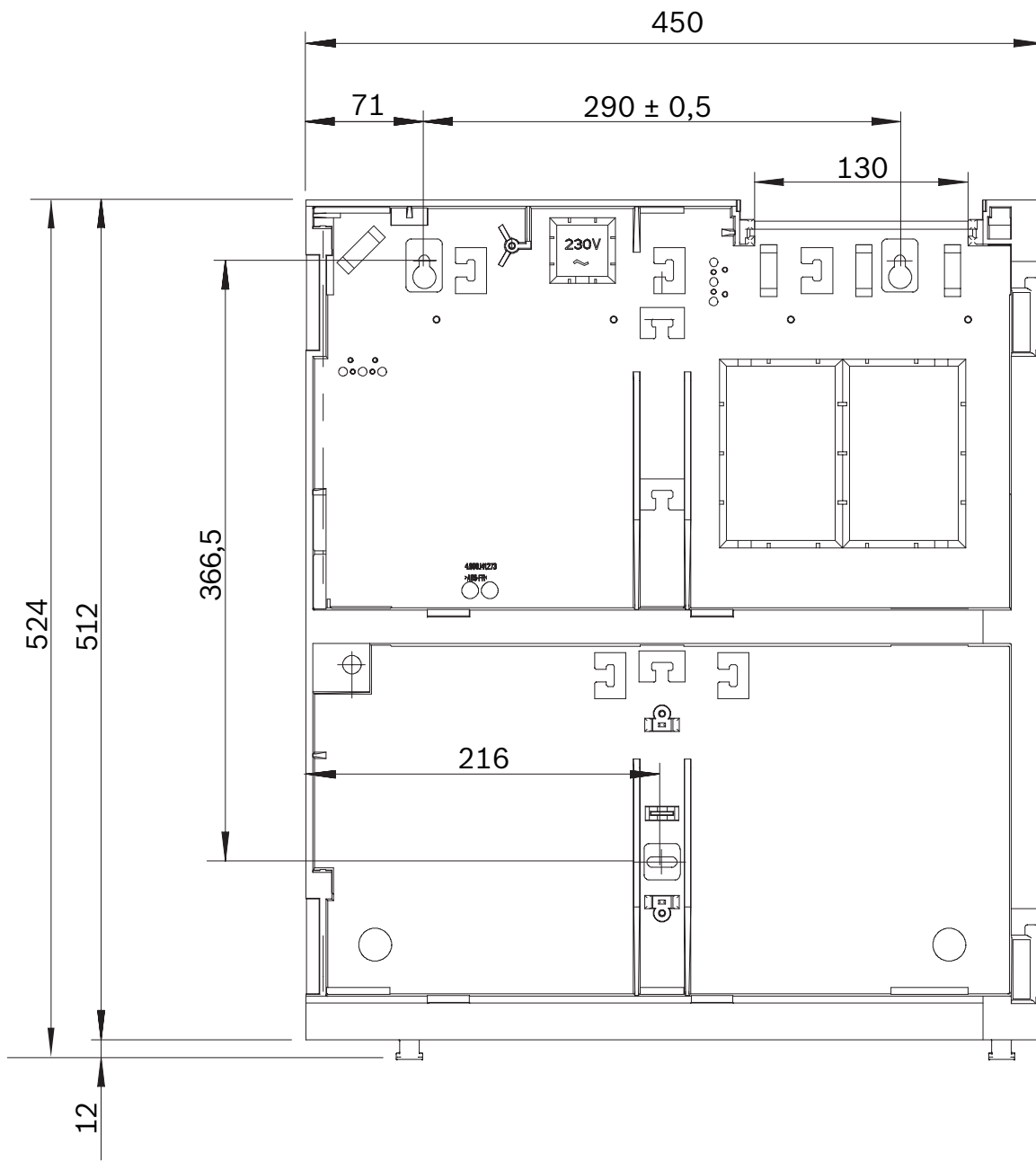

Figure 4.11: Installation dimensions - FMH 0000 A [in mm]

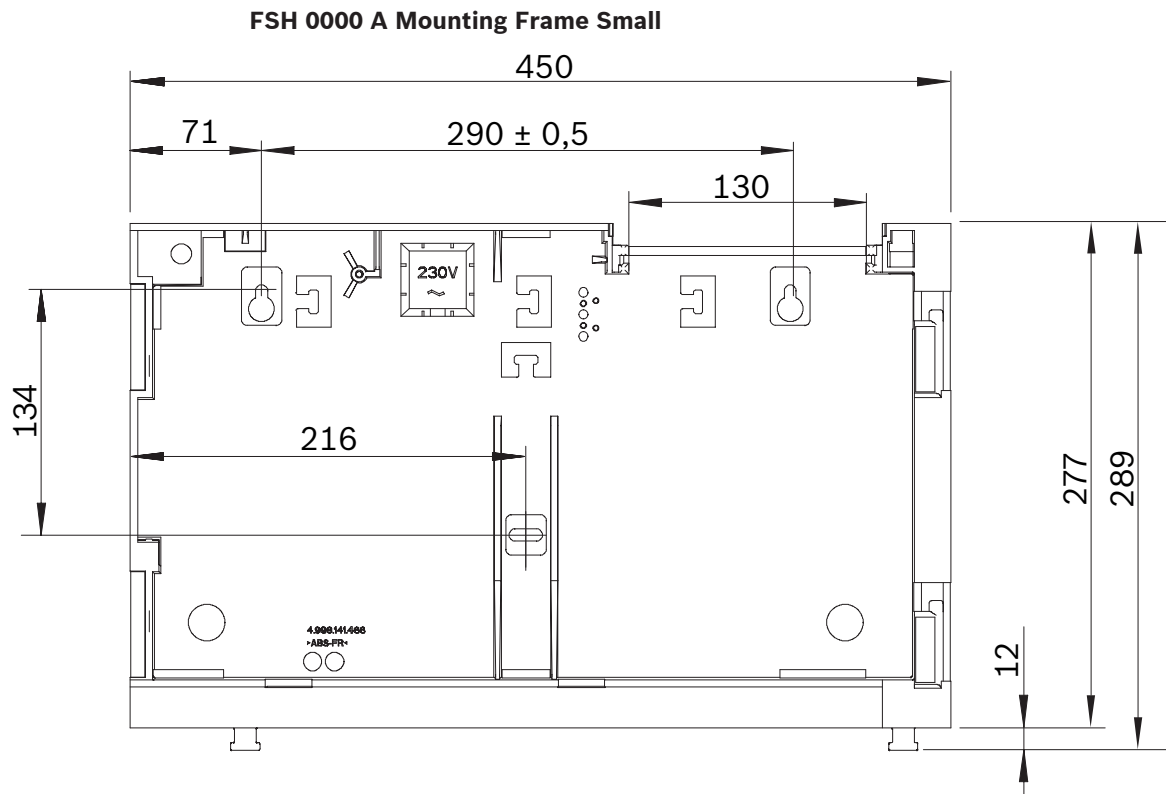

Figure 4.12: Installation dimensions - FSH 0000 A [in mm]

4.3.5 Installation Kits for 48 cm (19") Racks

FRK 0019 A Rack Installation Kit for All Wall Mounting Housings

The FRK 0019 A Rack Installation Kit is used to install wall mounting housings in 48 cm (19") racks.

The two mounting brackets in the universal installation kit are fitted at distance H (see *FRK 0019 A Rack Installation Kit for All Wall Mounting Housings, page 64*). The dimensions of H for the different wall mounting housings can be found in the table below:

Housing	H
PSS 0002 A	217 mm
DIB 0000 A	217 mm
PSB 0004 A	308 mm
HCP 0006 A	409 mm
HBC 0010 A	609 mm
HBE 0012 A	609 mm

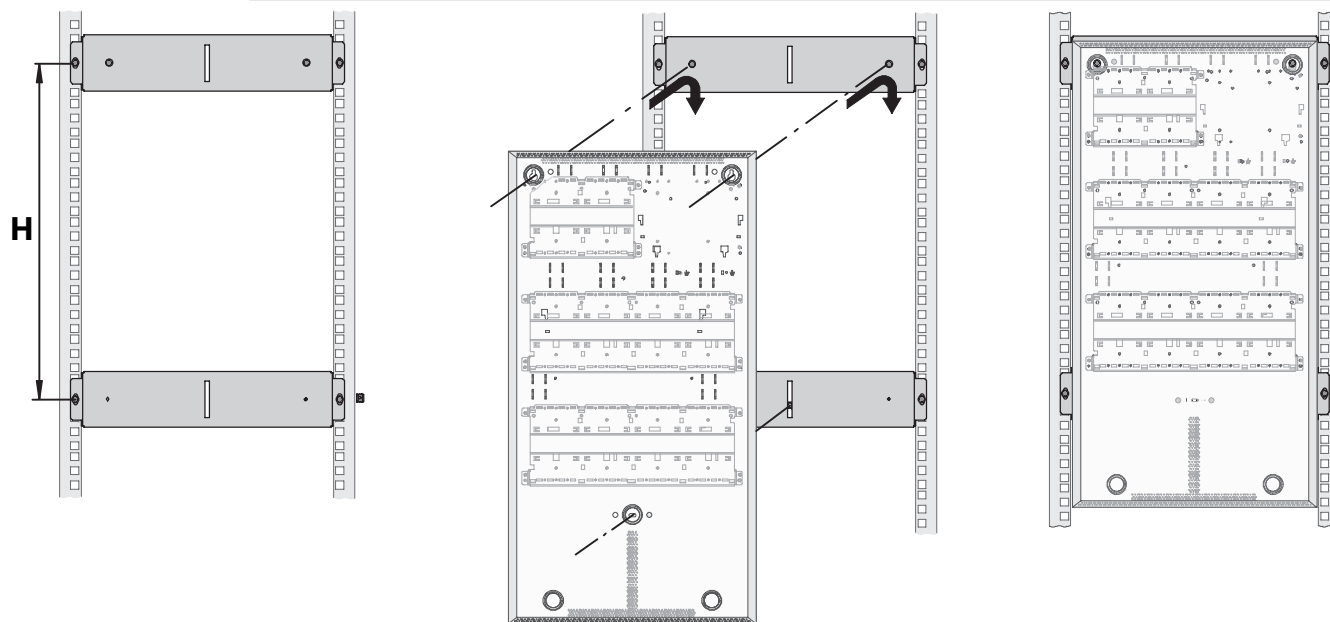

Figure 4.13: FRK 0019 A housing installation

Installation Kits for Frame Installation Housings

Special installation kits are available for installing frame installation housings in 48 cm (19") racks:

Housing type	Installation kit	Height unit
CPH 0006 A	FRB 0019 A	15
MPH 0010 A	FRB 0019 A	15
EPH 0012 A	FRB 0019 A	15
PMF 0004 A	FRM 0019 A	12
PSF 0002 A	FRS 0019 A	6
USF 0000 A	FRS 0019 A	6

No mounting frame is required when using the 48 cm (19") installation kits.
 The table below shows the space required for the different frame installation housings when using the installation kits for 48 cm (19") racks.

Installation kit	Housing types	Space required (H x B x T)
FRB 0019 A	CPH 0006 A, MPH 0010 A, EPH 0012 A	638 x 449 x 233.5 mm
FRM 0019 A	PMF 0004 A	502 x 449 x 233.5 mm
FRS 0019 A	PSF 0002 A, USF 0000 A	267 x 449 x 233.5 mm

FRB 0019 A Rack Installation Kit, Large

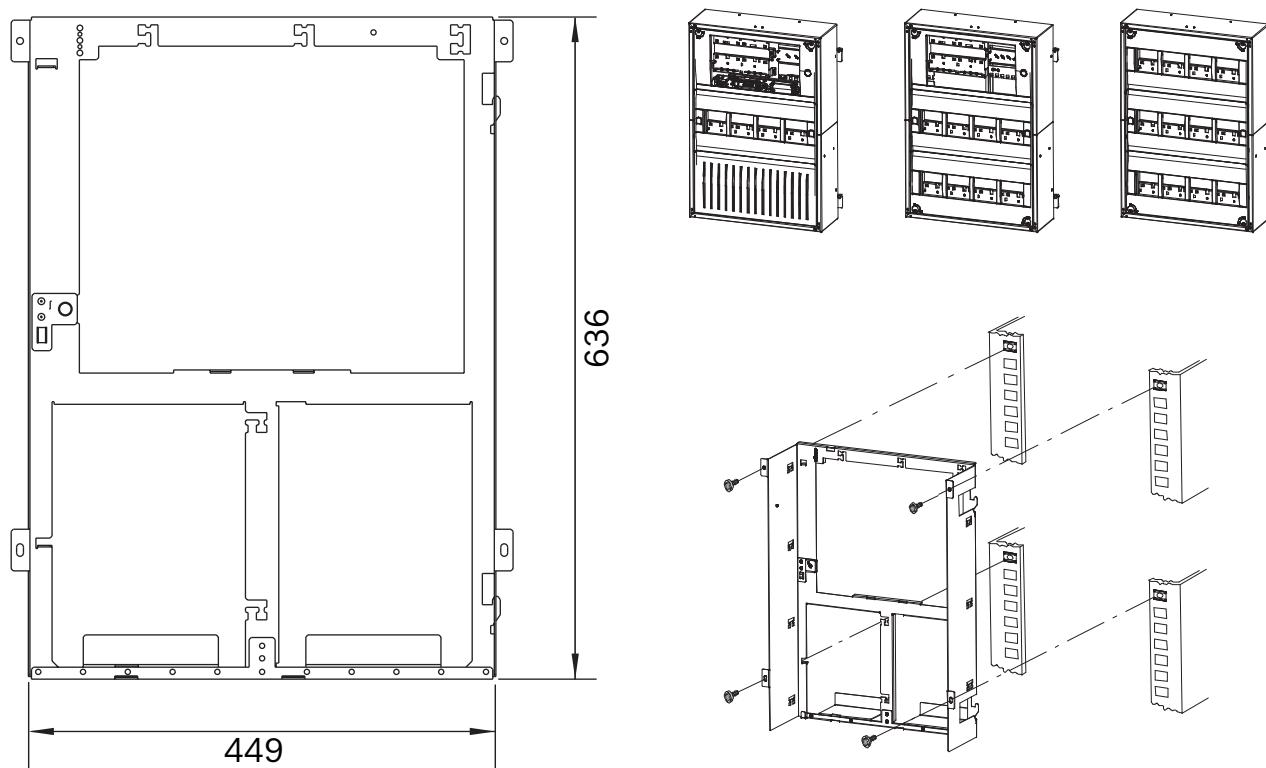

Figure 4.14: FRB 0019 A installation kit for CPH 0006 A, MPH 0010 A, EPH 0012 A [installation dimensions in mm]

FRM 0019 A Rack Installation Kit, Medium

Figure 4.15: FRM 0019 A installation kit for PMF 0004 A [installation dimensions in mm]

FRS 0019 A Rack Installation Kit, Small

Figure 4.16: FRS 0019 A installation kit for PSF 0002 A, USF 0000 A [installation dimensions in mm]

The FRS 0019 A installation kit is also used for the THP 2020 A Thermal Printer.

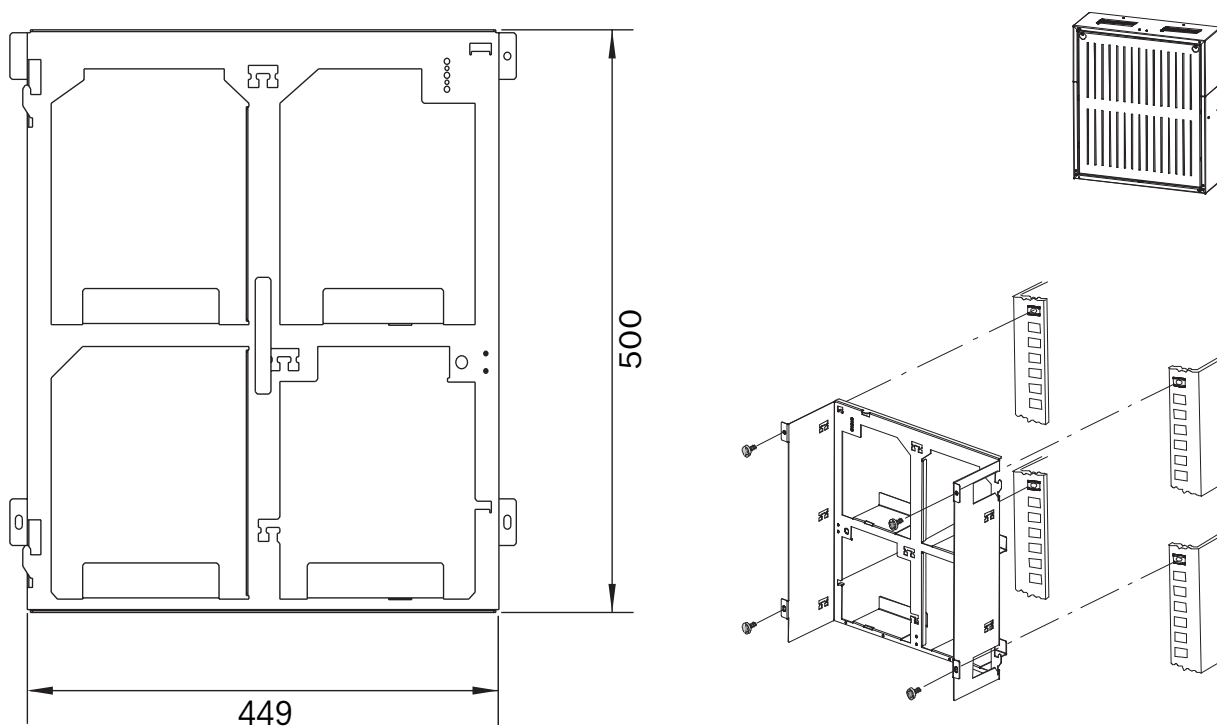
4.4 Accessories for Housing

4.4.1 RLE 0000 A Junction Board

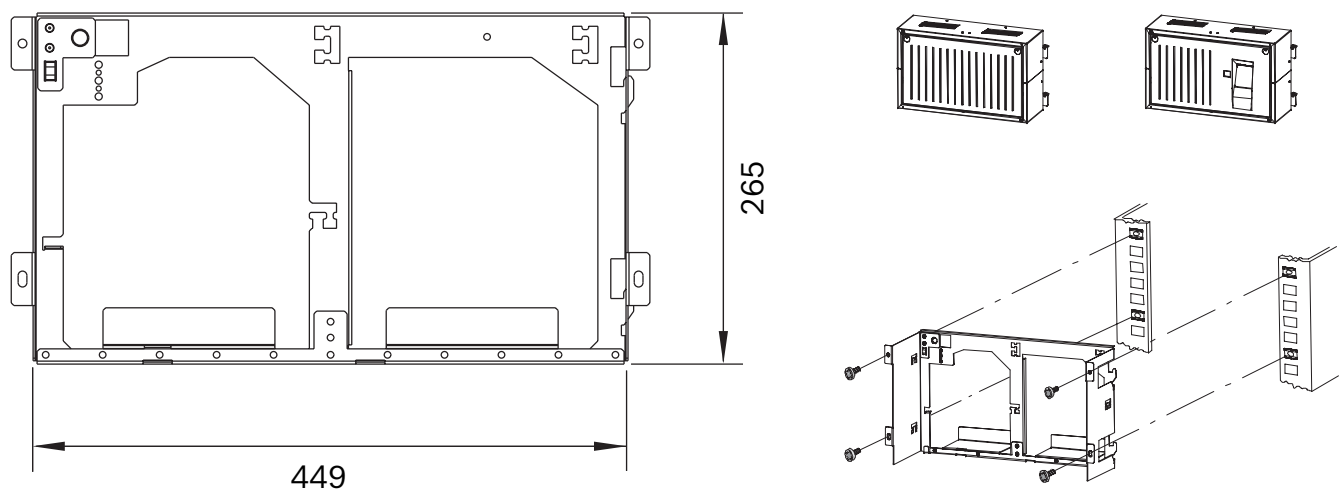
The RLE 0000 A Junction Board is designed for installation in the CPH 0006 and MPH 0010 A frame installation housings.

Junction boards receive the cables coming from outside and allow clear onward transmission to the individual modules.

The RLE 0000 A Junction Board is also required to connect the AT3000 transmission unit.

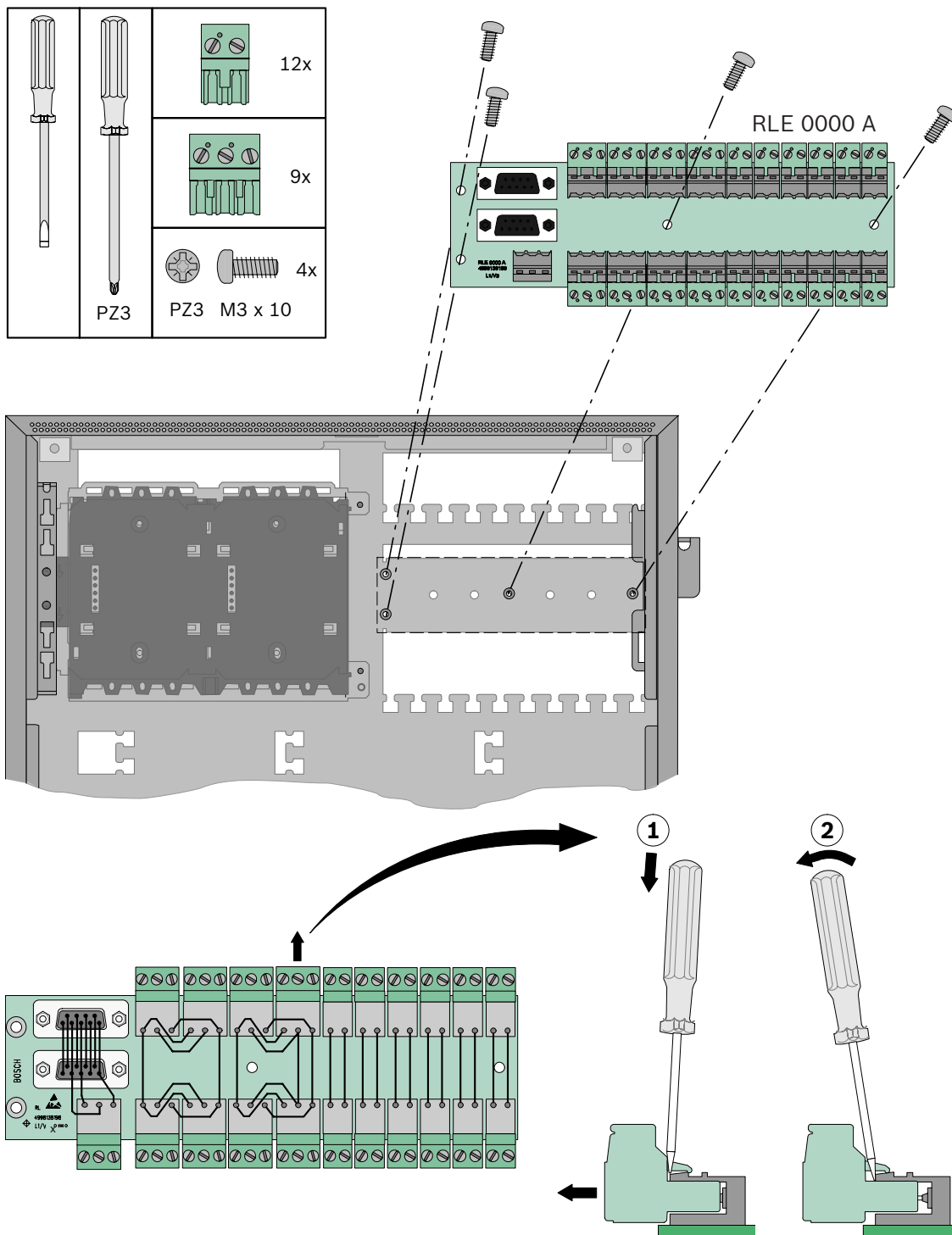

Figure 4.17: RLE 0000 A installation

4.4.2 HMP 0003 A Mounting Plate for Mounting Frame

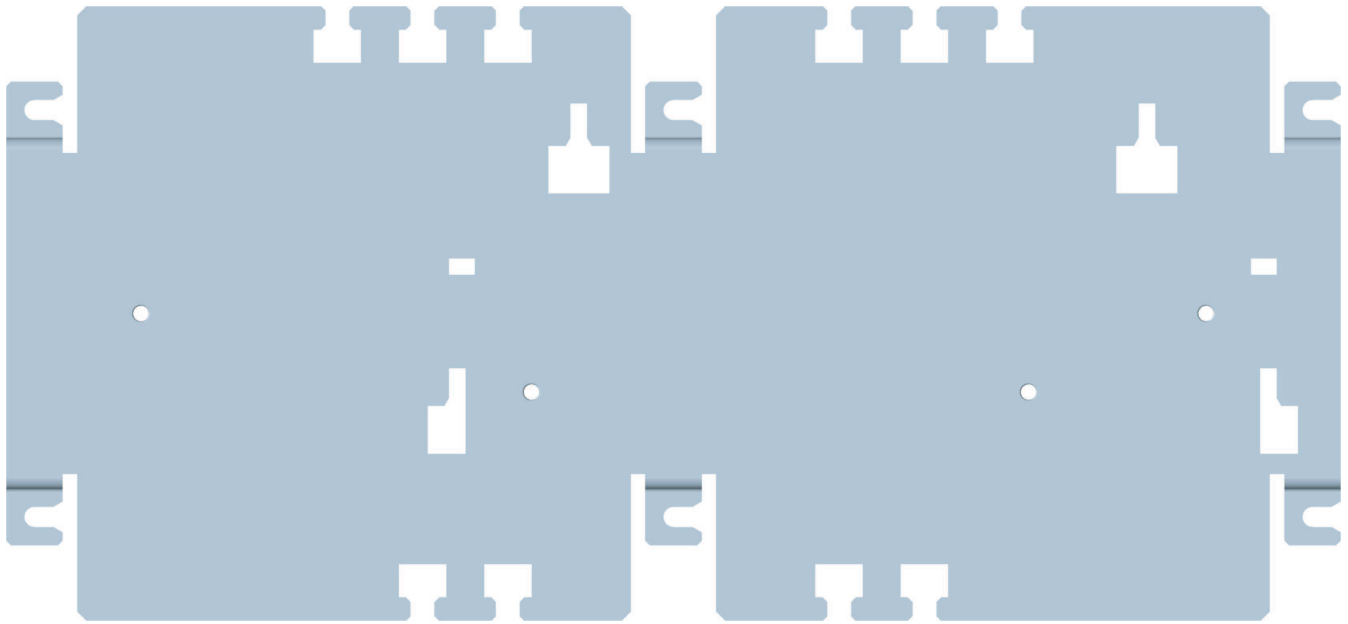

Figure 4.18: HMP 0003 A Mounting Plate for Mounting Frame

The HMP 0003 A Mounting Plate is used in both the large FBH 0000 A and FHS 0000 A mounting frames.

The mounting plate is required to install interface modules, external device controllers, relays and other components. It can be fitted with a distributor rail.



Notice!

The distributor rail is not included in the scope of delivery for the HMP 0003 A Mounting Plate.

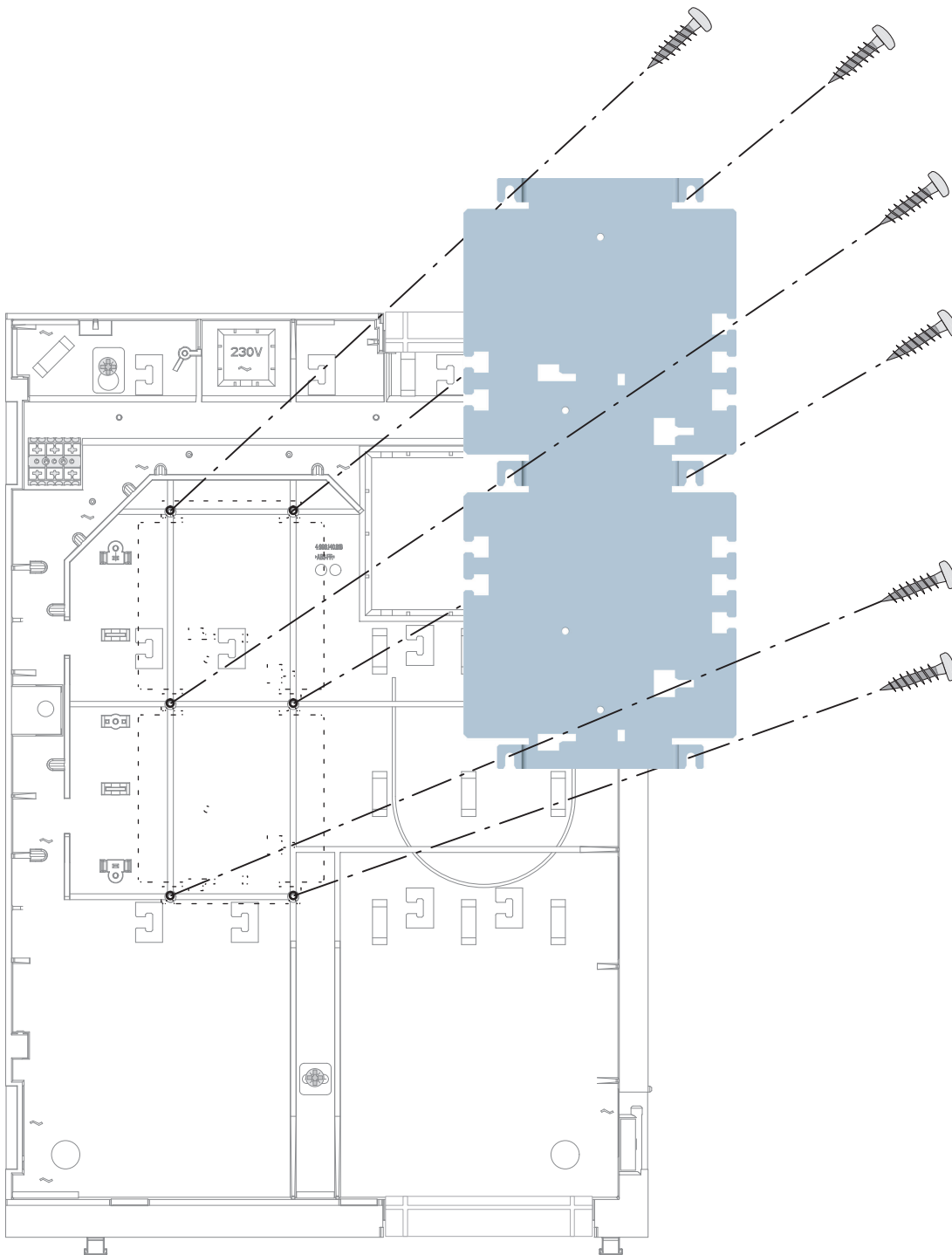

Figure 4.19: HMP 0003 A installation

4.4.3 FPO-5000-EB Earth Bar

The FPO-5000-EB Earth Bar is inserted in the FMH 0000 A Mounting Frame Medium in a prefabricated bracket. It allows star grounding of a centrally positioned extension housing.

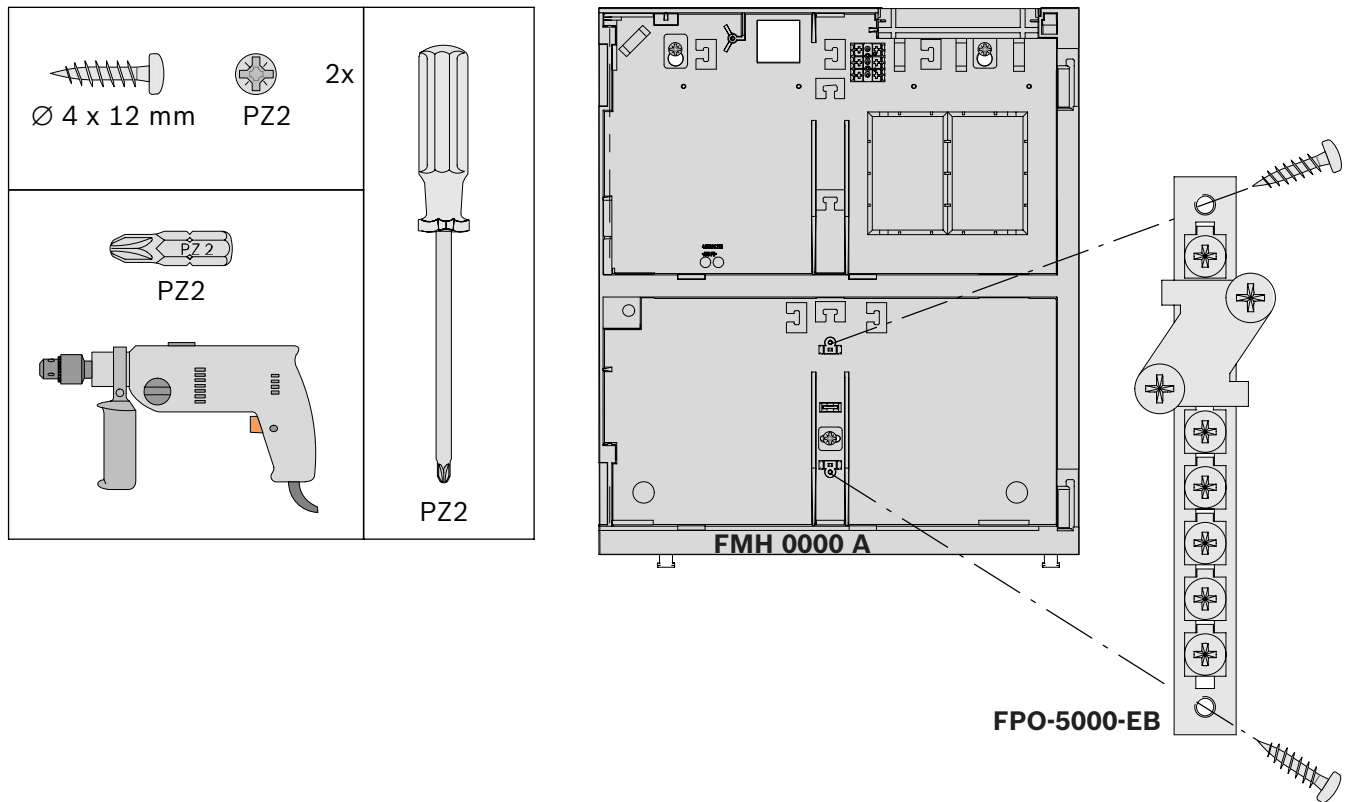

Figure 4.20: FPO-5000-EB installation

4.5 Power Supply Brackets



Danger!

The device contains live components.
Touching live components entails a risk of death or serious injury.
Disconnect the power supply before all installation work.

The power supply brackets are designed for installation in wall mounting housings and can hold a UPS 2416 A Universal Power Supply. This is ready for immediate operation via the pre-wired plug connection.

The brackets are made of fiberglass-reinforced plastic and have a fuse (T 10 A) and a temperature sensor, which is positioned between the batteries.



Warning!

There is a risk of injury if the temperature sensor is not positioned between the batteries.
The temperature sensor is supplied with the power supply bracket and protects the batteries against overheating. If the sensor is not positioned correctly, the batteries can overheat and explode.

Position the temperature sensor between the batteries.

Power supply brackets are available in the FPO-5000-PSB-CH (see *FPO-5000-PSB-CH Power Supply Bracket*, page 72) and FPO-5000-PSB1 (see *FPO-5000-PSB1 Power Supply Bracket*, page 76) versions.

All frame installation housings designed for a power supply bracket are supplied with one of these brackets, which is fitted ex works.



Notice!

A maximum of one power supply bracket and one power supply can be installed in the power supply housing.

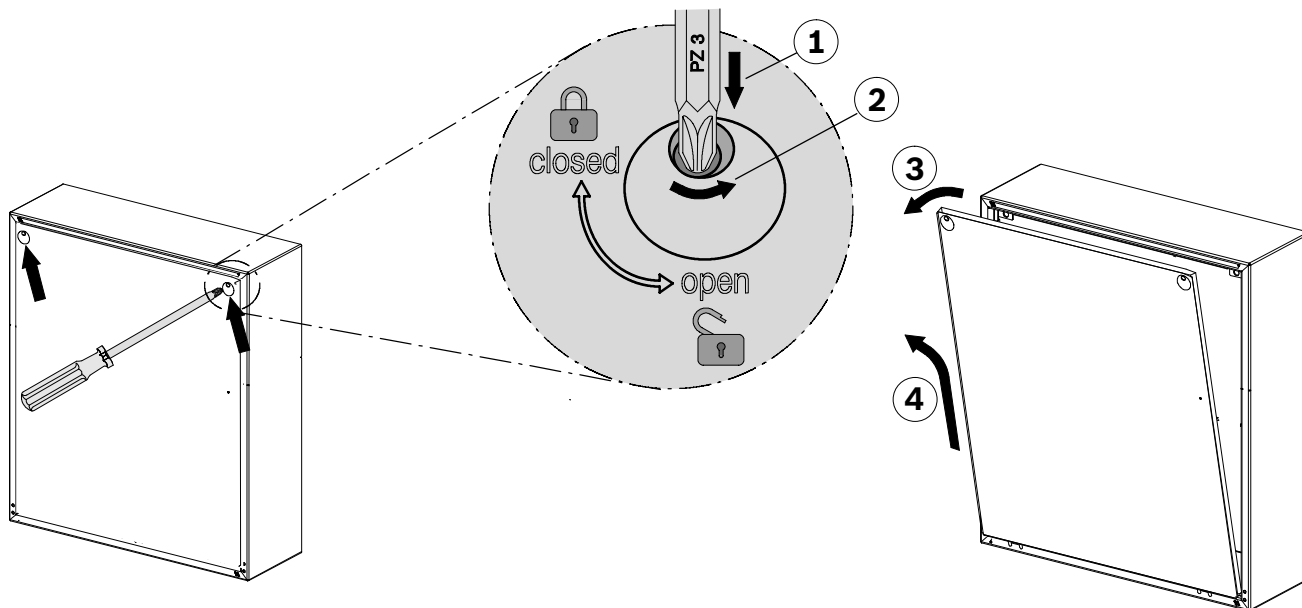
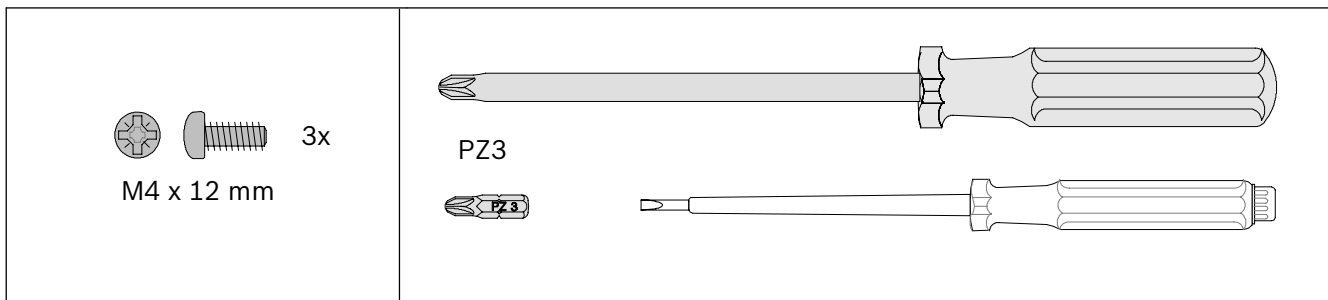

Figure 4.21: FPO-5000-PSB-CH/FPO-5000-PSB1 installation (1-4)

4.5.1 FPO-5000-PSB-CH Power Supply Bracket

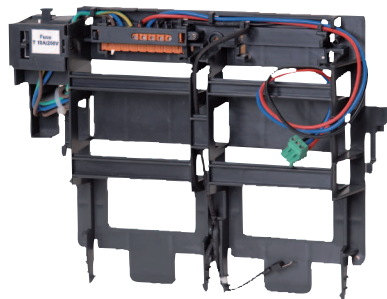

Figure 4.22: FPO-5000-PSB-CH Power Supply Bracket

The FPO-5000-PSB-CH Power Supply Bracket is used in the HCP 0006 A, HBC 0010 A and HBE 0012 A wall mounting housings.

The technical data can be found in *FPO-5000-PSB1/FPO-5000-PSB-CH Power Supply Brackets*, page 147.

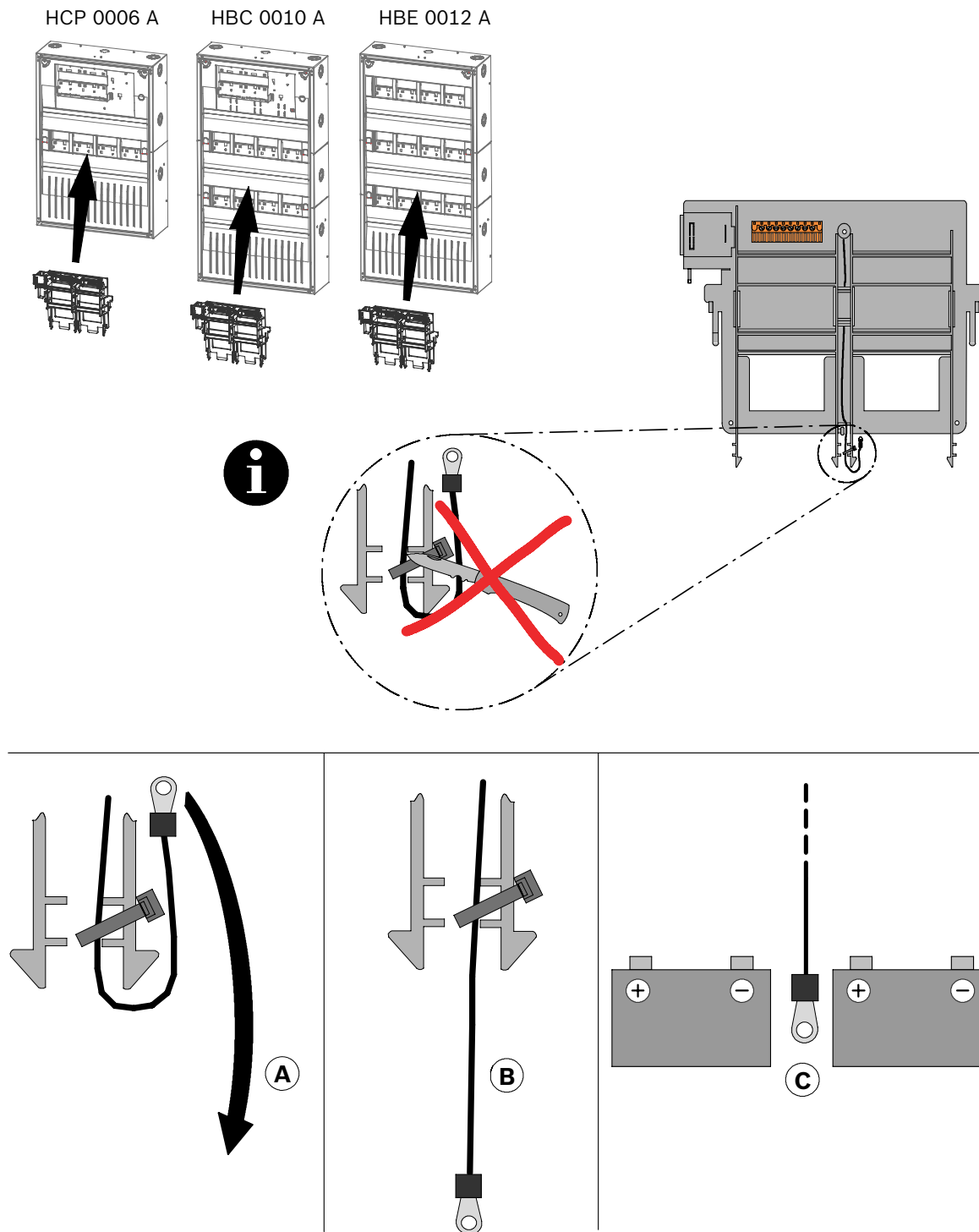

Figure 4.23: FPO-5000-PSB-CH housing compatibility and installation of temperature sensor

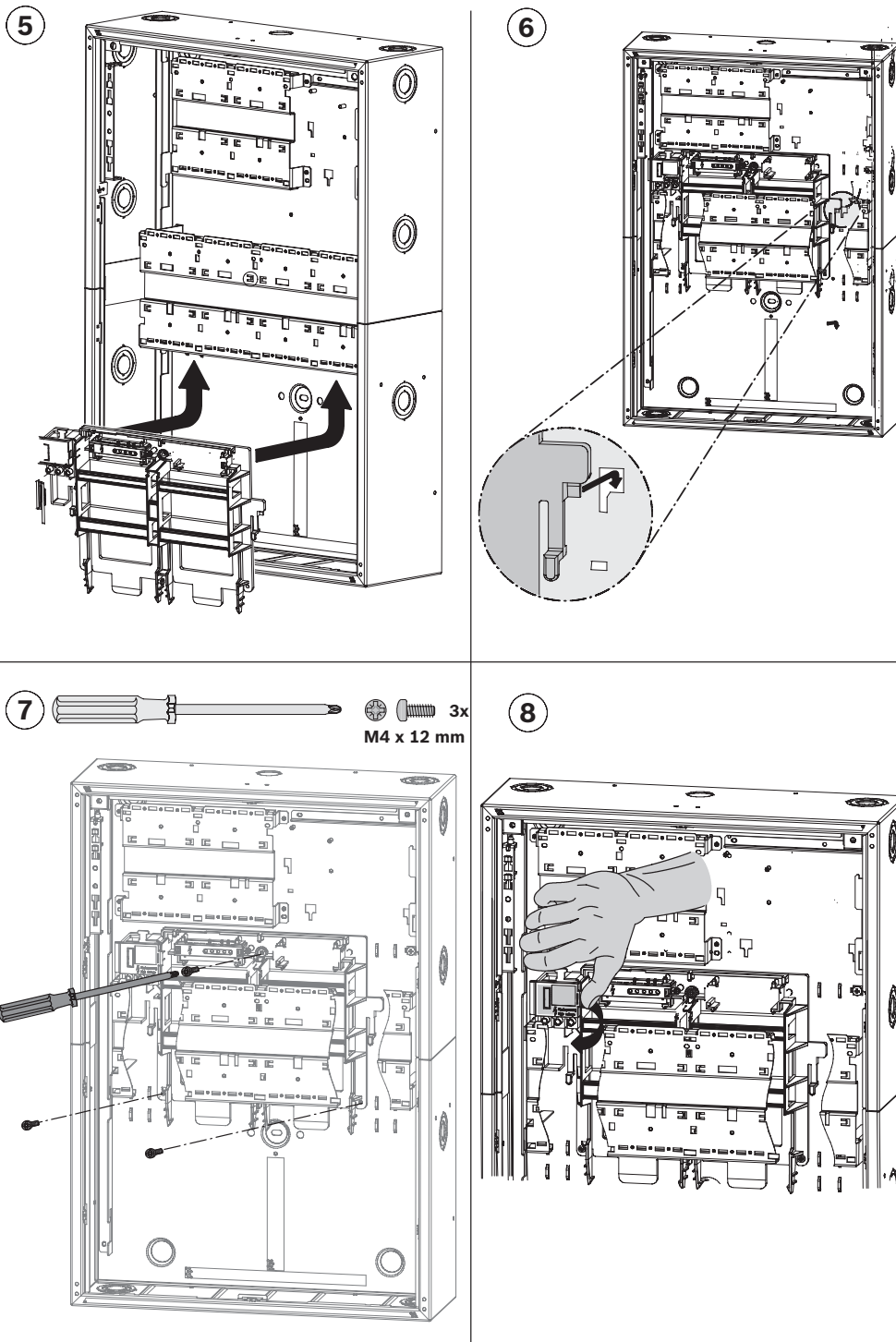

Figure 4.24: FPO-5000-PSB-CH installation (5-8)

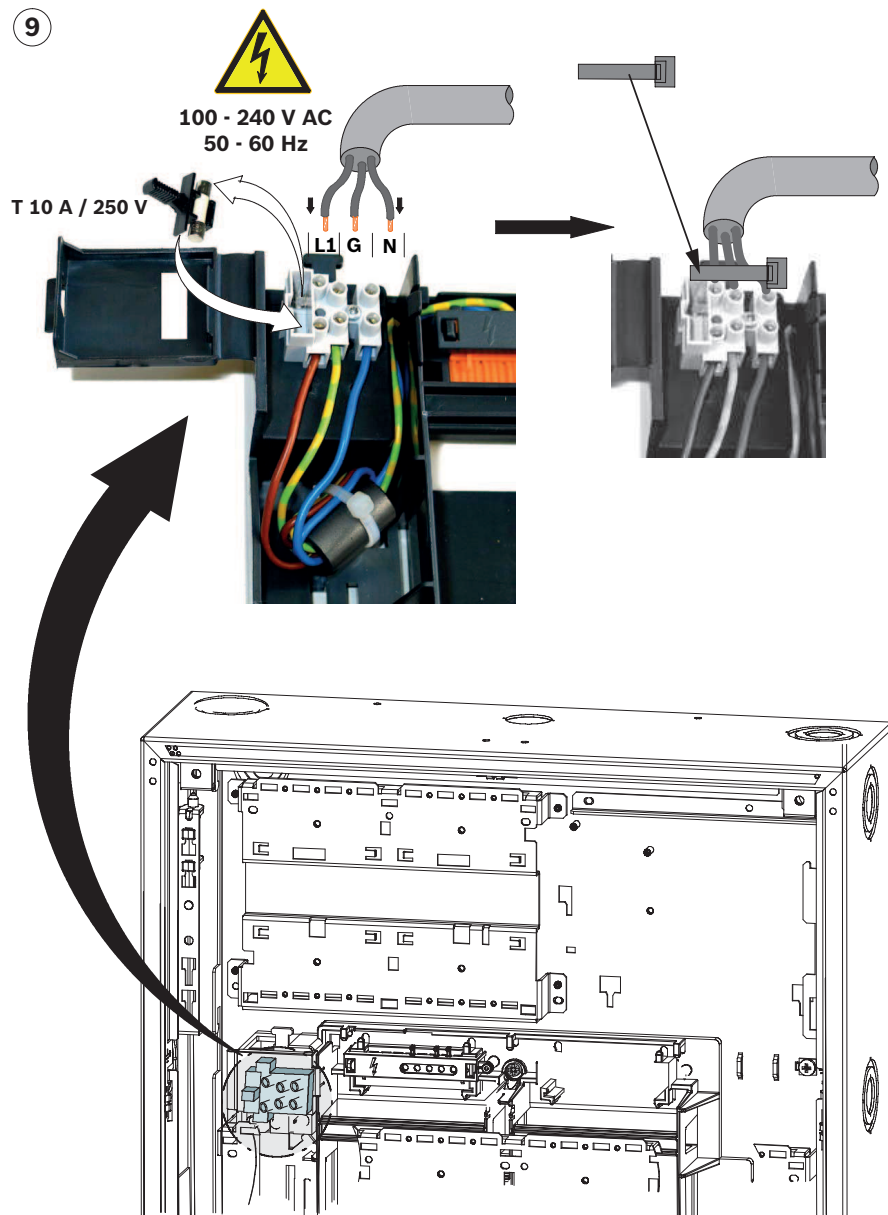

Figure 4.25: FPO-5000-PSB-CH installation (9)

4.5.2 FPO-5000-PSB1 Power Supply Bracket



Figure 4.26: FPO-5000-PSB1 Power Supply Bracket

The FPO-5000-PSB1 Power Supply Bracket is used in the PSS 0002 A and PSB 0004 A power supply housings.

It is installed in a central position between two batteries.

The technical data can be found in *FPO-5000-PSB1/FPO-5000-PSB-CH Power Supply Brackets*, page 147.

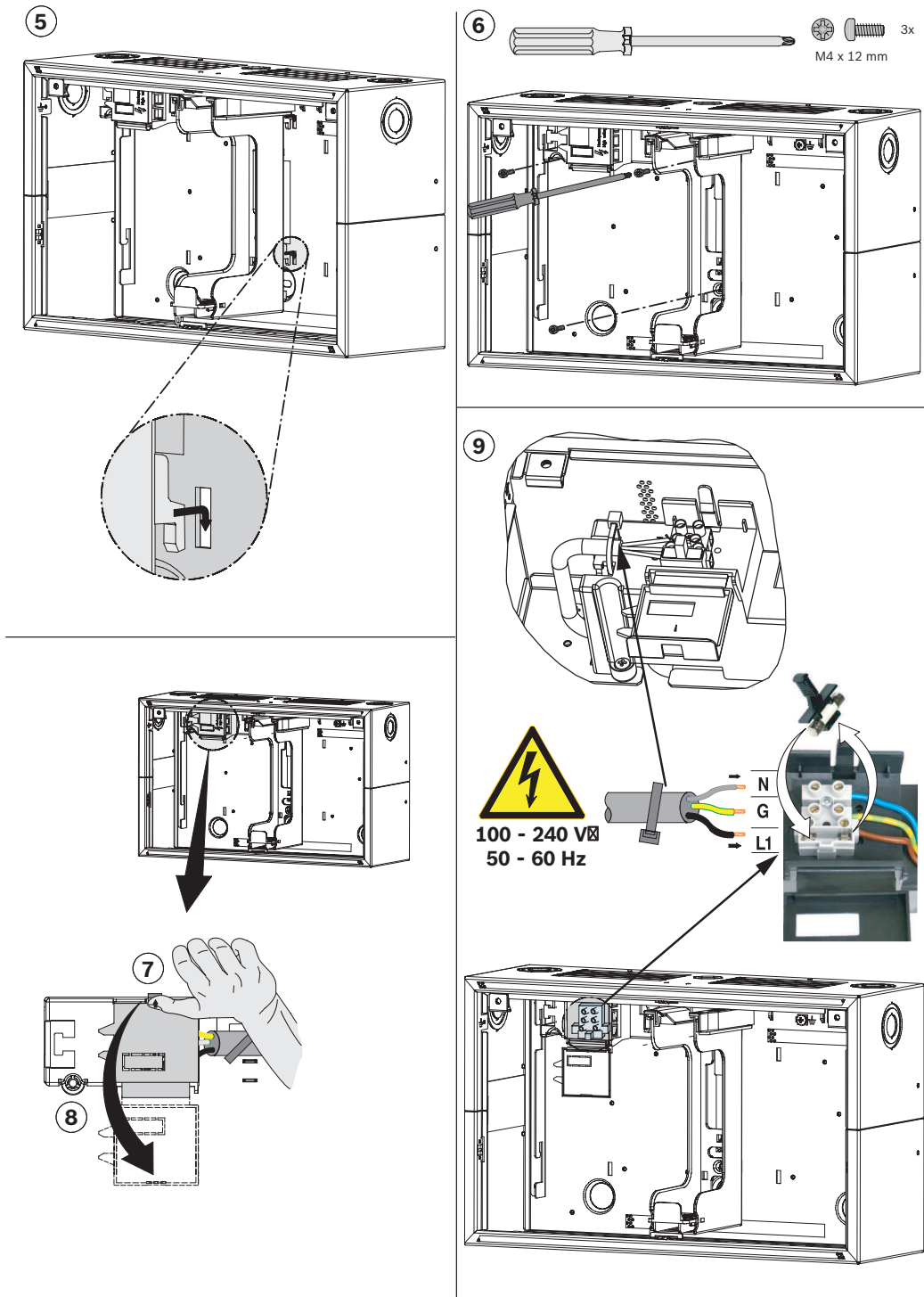

Figure 4.27: FPO-5000-PSB1 installation (5-9)

4.6 UPS 2416 A Universal Power Supply 24 V/6 A

The UPS 2416 A is a plug-and-play switching power supply that provides the power for the FPA-5000 Fire Panel. It is inserted into a power supply bracket and is then ready to use immediately.

The power supply unit is protected against pole reversal and overvoltage. A green LED on the power supply unit itself indicates that it is functioning.

The temperature-dependent output voltage is monitored and regulated by the BCM Battery Controller Module.

The output voltage is monitored and regulated by a temperature sensor. If there is a fault, the FAULT output drops to 0 V.



Warning!

The power supply unit may only be used in the specially designed brackets and in a fireproof cover (such as a panel housing).



Warning!

There is a risk of injury if the temperature sensor is not positioned between the batteries. The temperature sensor is supplied with the power supply bracket and protects the batteries against overheating. If the sensor is not positioned correctly, the batteries can overheat and explode.

Position the temperature sensor between the batteries.

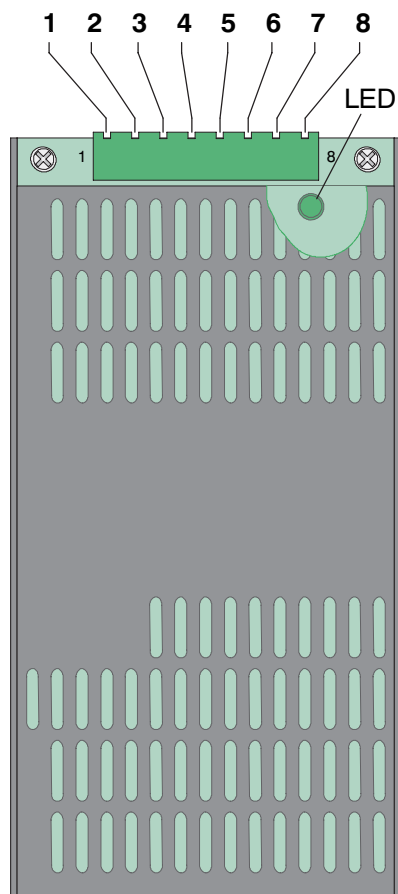

Figure 4.28: UPS 2416 A Universal Power Supply 24 V/6 A

Pos.	Labeling	Connection
1 - 2	ACL ACN	Mains supply
3		Protective ground
4 - 5	DC+ DC-	26.76 V DC output plus/0 V DC output minus
6	FAULT	Mains fault output

Pos.	Labeling	Connection
7 - 8	RTH+ RTH-	Temperature sensor plus/minus

The universal power supply is used with the FPO-5000-PSB1 and FPO-5000-PSB-CH Power Supply Brackets. These power supply brackets can be used in the following wall mounting housings:

Power supply bracket	Housing
FPO-5000-PSB1	PSS 0002 A, PSB 0004 A
FPO-5000-PSB-CH	HCP 0006 A, HBC 0010 A, HBE 0012 A

Information on power supply brackets can be found in *Power Supply Brackets*, page 70.

The technical data can be found in *UPS 2416 A Universal Power Supply 24 V/6 A*, page 148.



UPS 2416 A

⊗ FPO-5000-PSB1

1

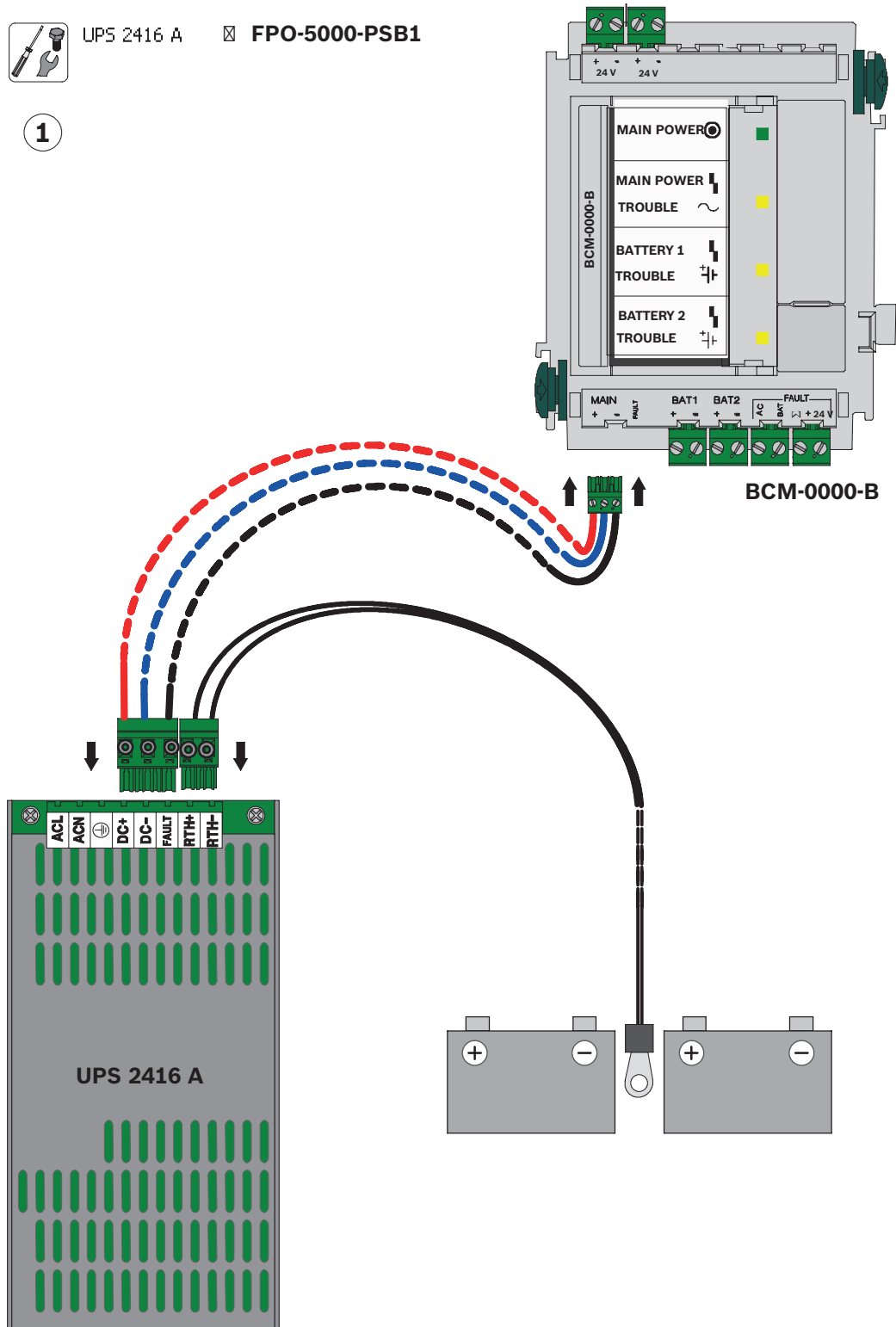

Figure 4.29: Installation of UPS 2416 A in FPO-5000-PSB1 (1)

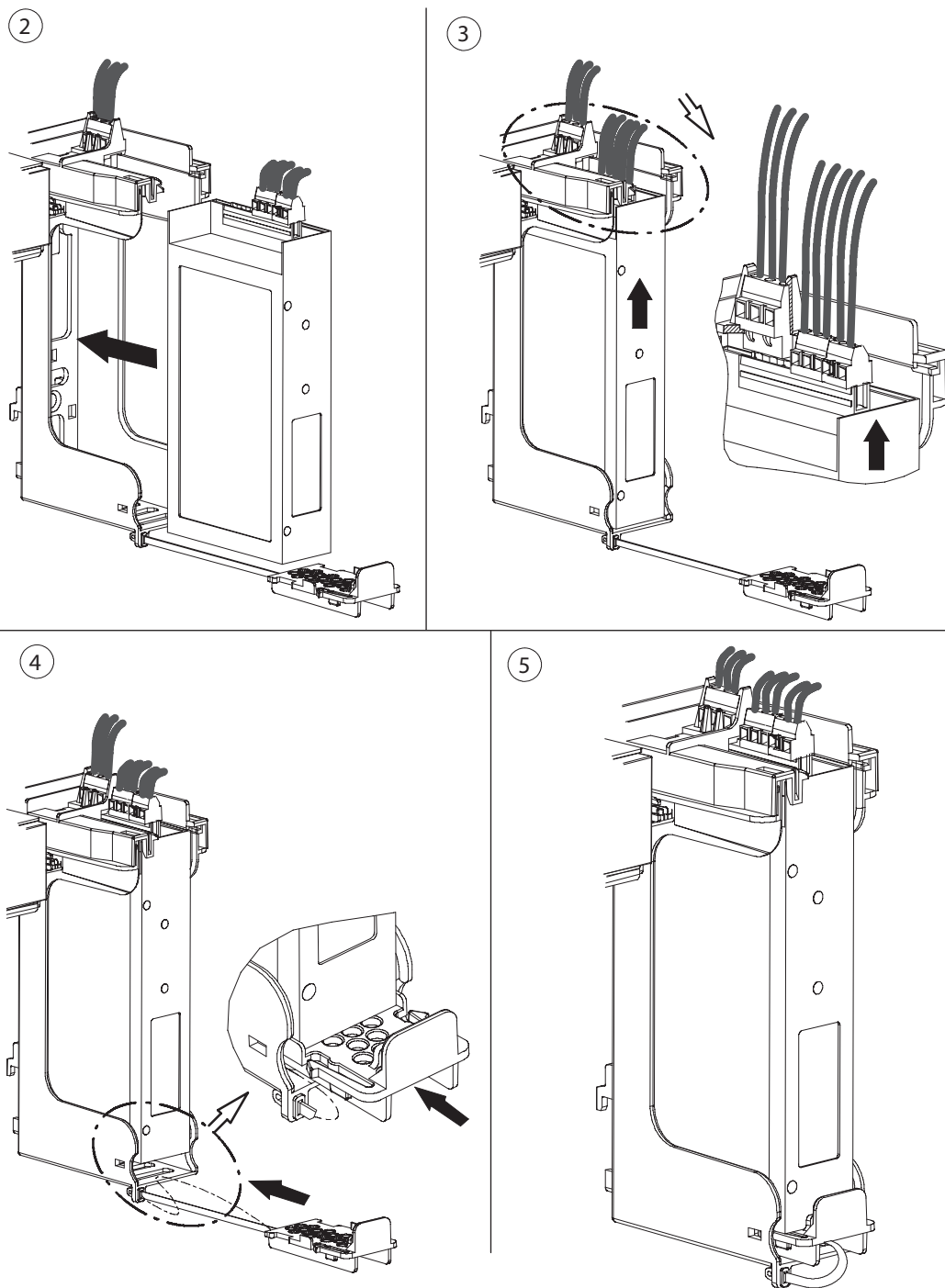
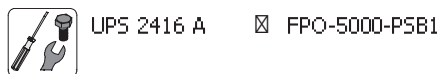

Figure 4.30: Installation of UPS 2416 A in FPO-5000-PSB1 (2-5)



Notice!

Only one power supply unit can be installed in the FPO-5000-PSB-CH Power Supply Bracket (see figure).

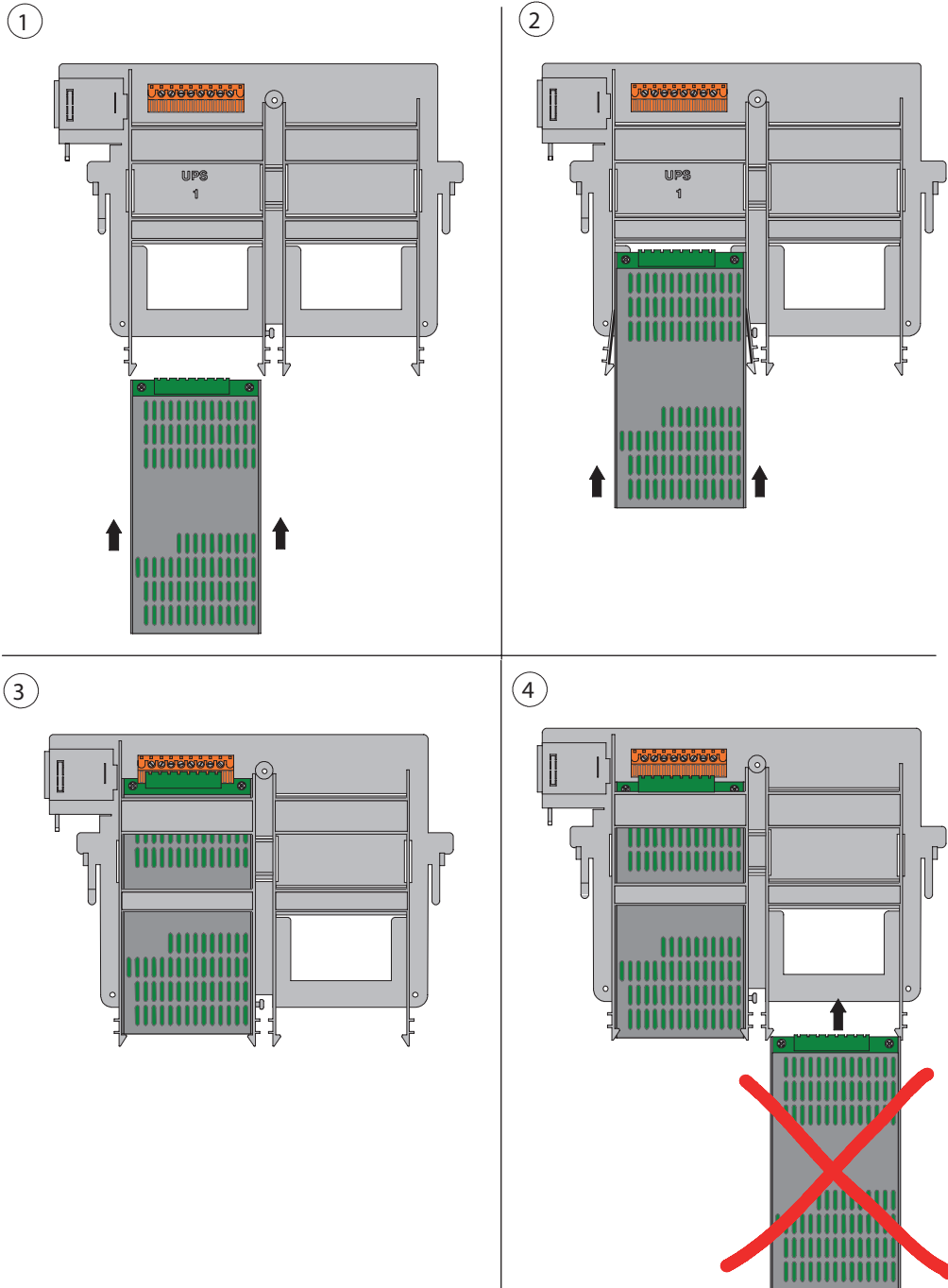
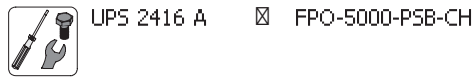

Figure 4.31: Installation of UPS 2416 A in FPO-5000-PSB-CH (1-4)



Notice!

Each power supply unit and each housing comes with a self-adhesive product label. Attach the sticker to the outside of the housing (see figure).

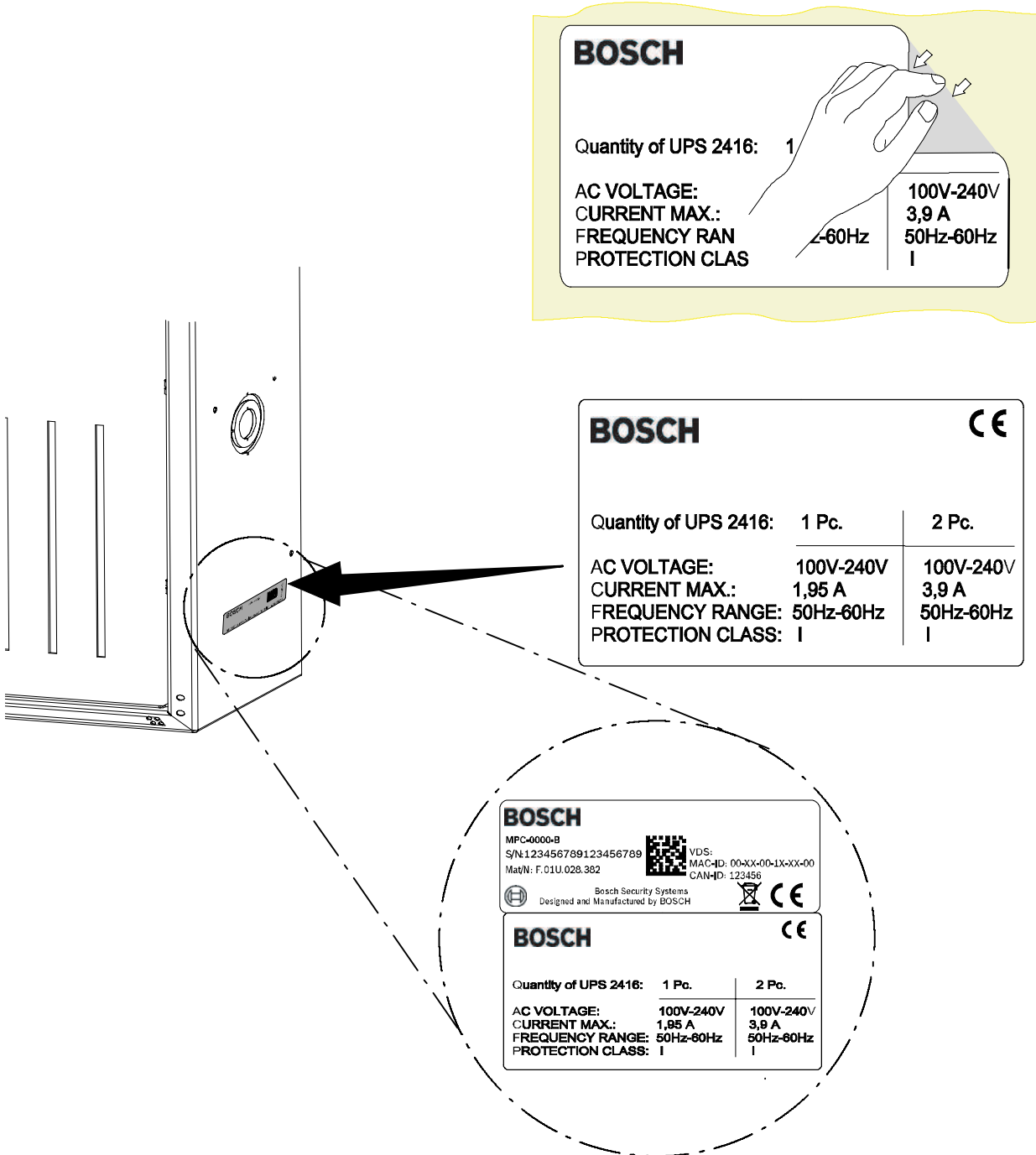

Figure 4.32: Attaching the stickers

4.7 Panel Rails

4.7.1 PRS-0002-C Panel Rail Short for 2 Modules

The PRS-0002-C Panel Rail Short has two module slots and is supplied with 24 V DC by the BCM-0000-B. An integrated voltage converter then generates the 5 V DC operating voltage required by the modules. Due to its concealed position behind the operating and display panel, the PRS-0002-C Panel Rail Short is intended for installation of the following modules without operating and display elements:

- BCM-0000-B Battery Controller Module
- IOS 0020 A and IOS 0232 A Communication Modules

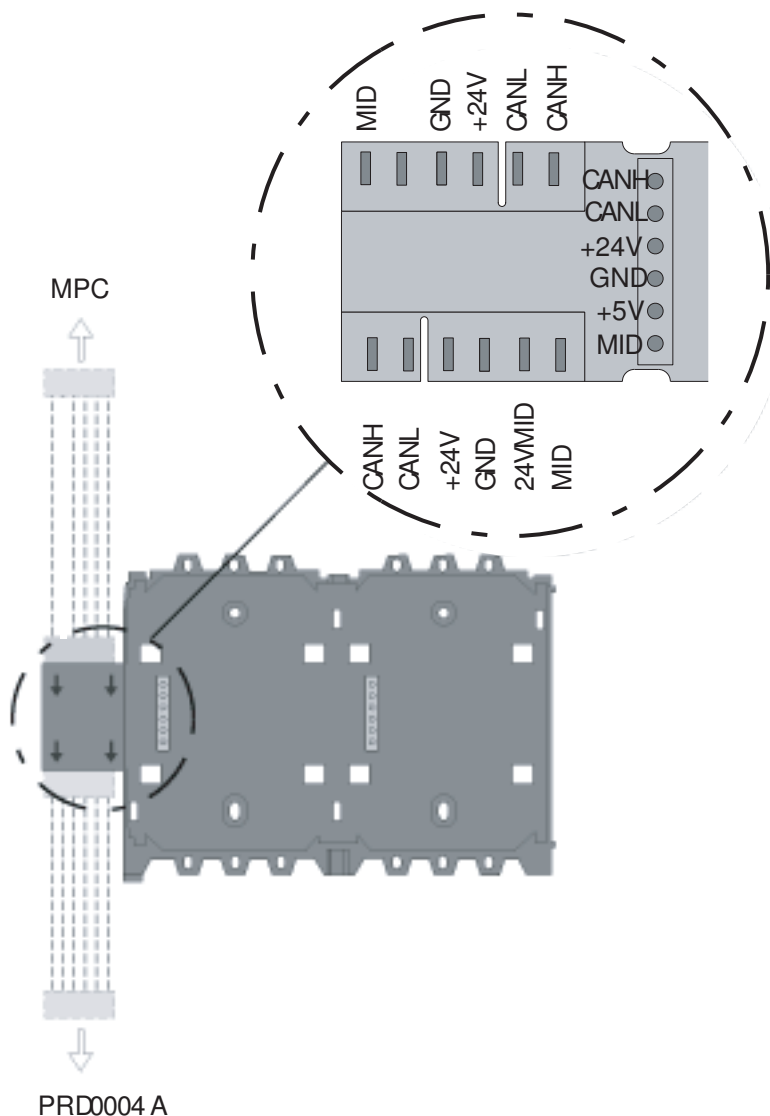

Figure 4.33: PRS-0002-C connections

The technical data can be found in *PRS-0002-C Panel Rail Short for 2 Modules*, page 147.

4.7.2

PRD 0004 A Panel Rail Long for 4 Modules

The PRD 0004 A Panel Rail Long has four module slots and is supplied with 24 V DC by the BCM. An integrated voltage converter then generates the 5 V DC operating voltage required by the modules.

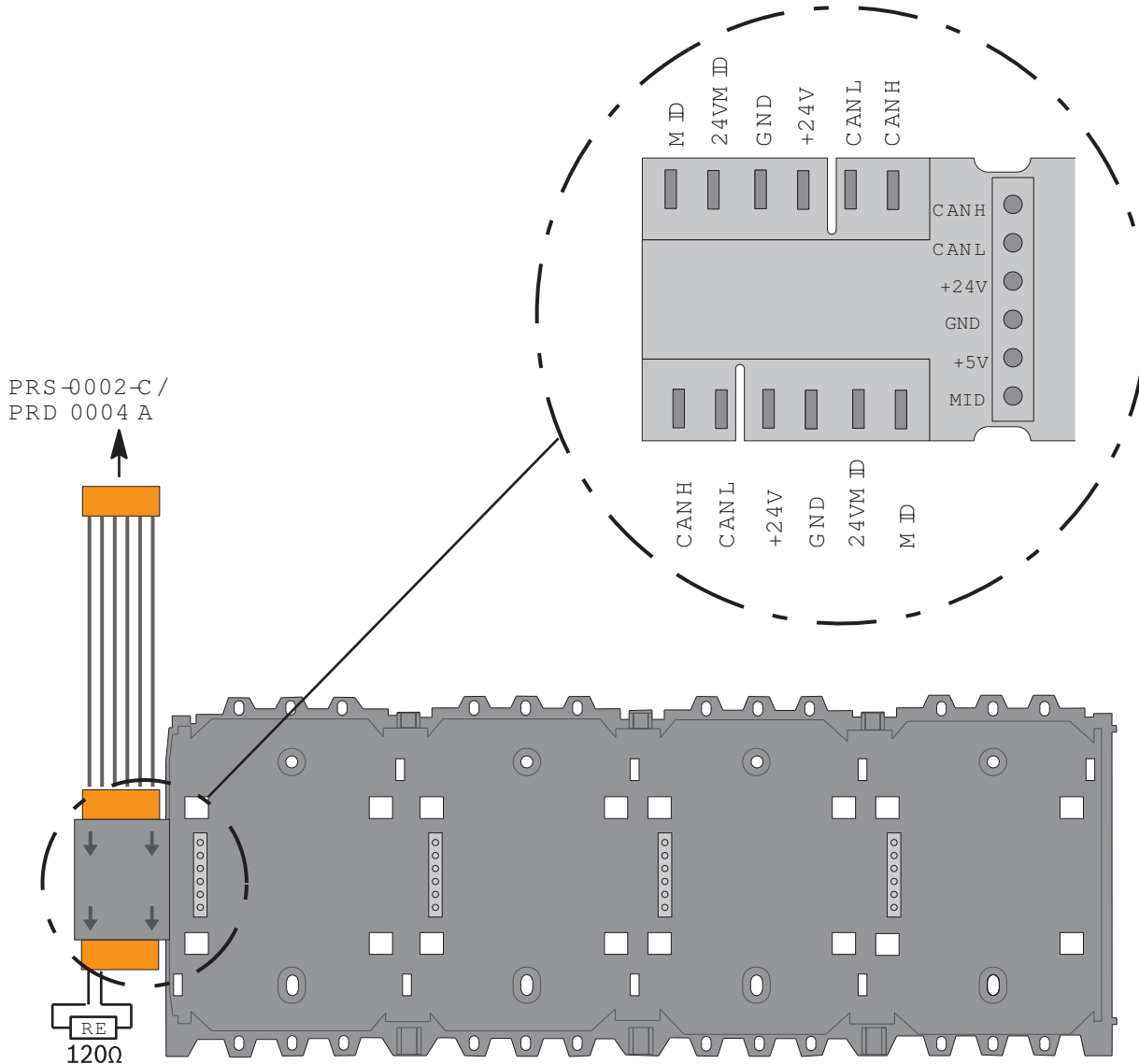

Figure 4.34: PRD 0004 A connections

The technical data can be found in *PRD 0004 A Panel Rail Long for 4 Modules*, page 147. A line terminator (RE) has to be plugged at the open end of the last rail.

4.7.3 Panel Rail Installation

Short rail installation

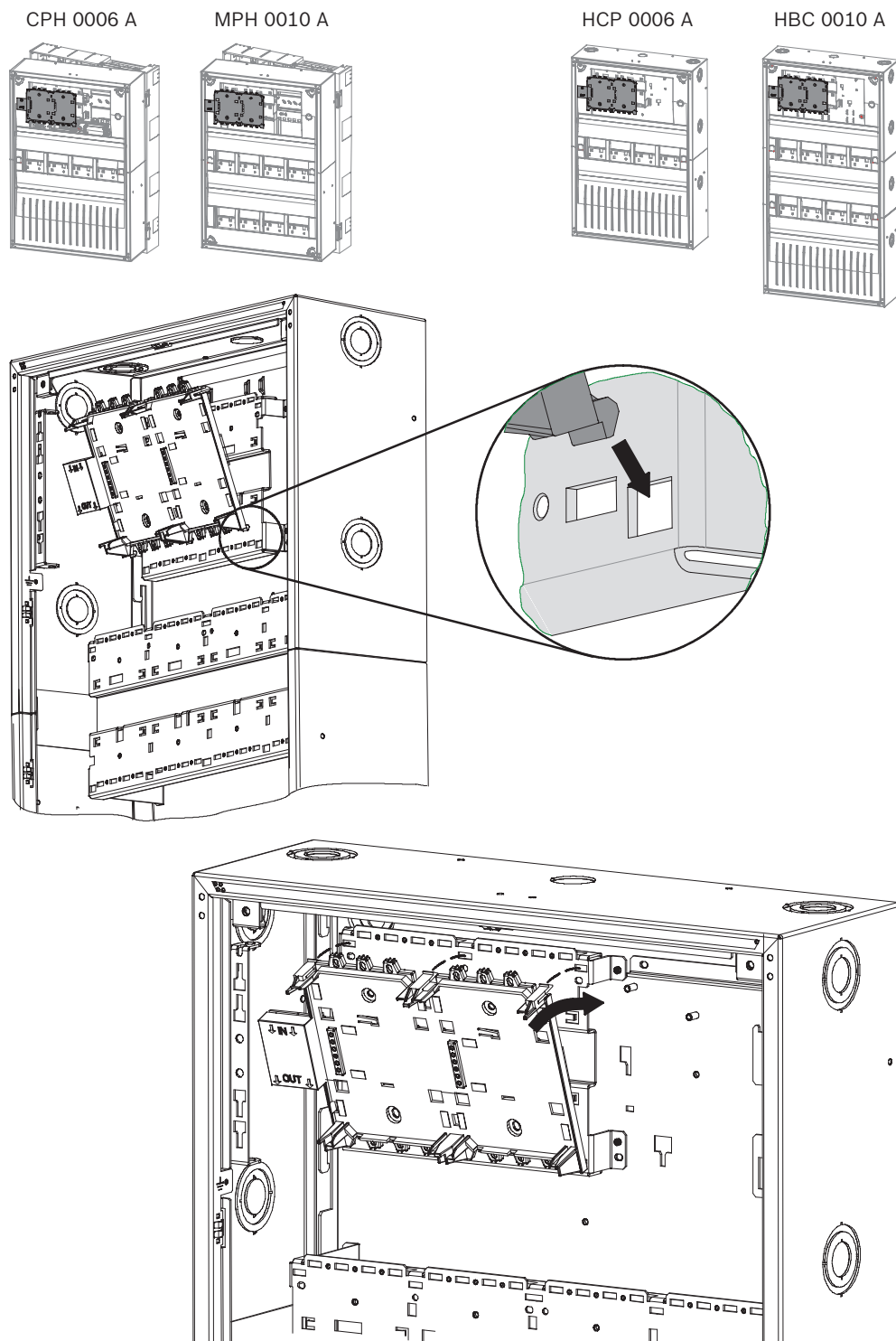

Figure 4.35: PRS-002-C installation

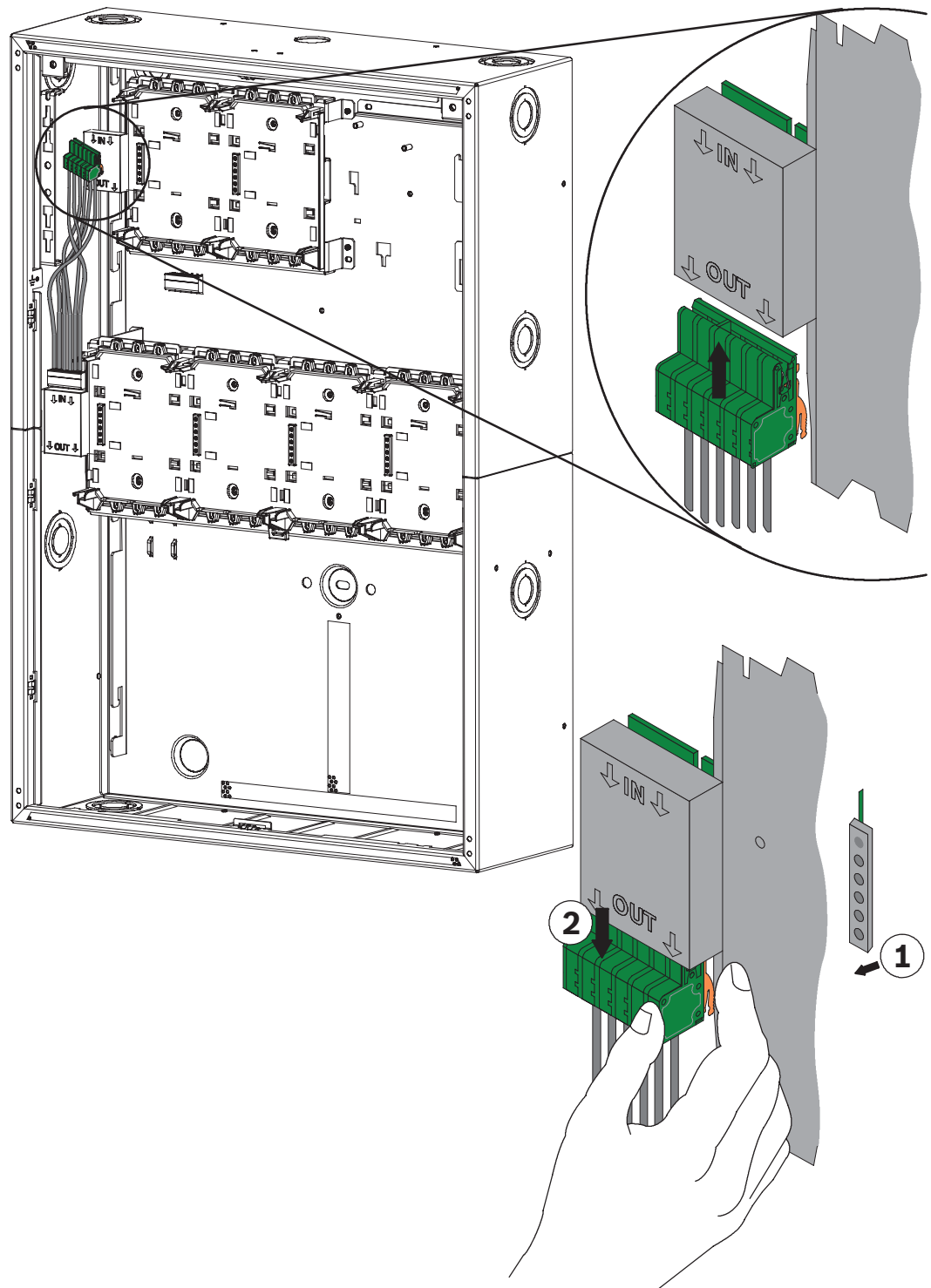

Figure 4.36: Connection of panel rail

Long rail installation

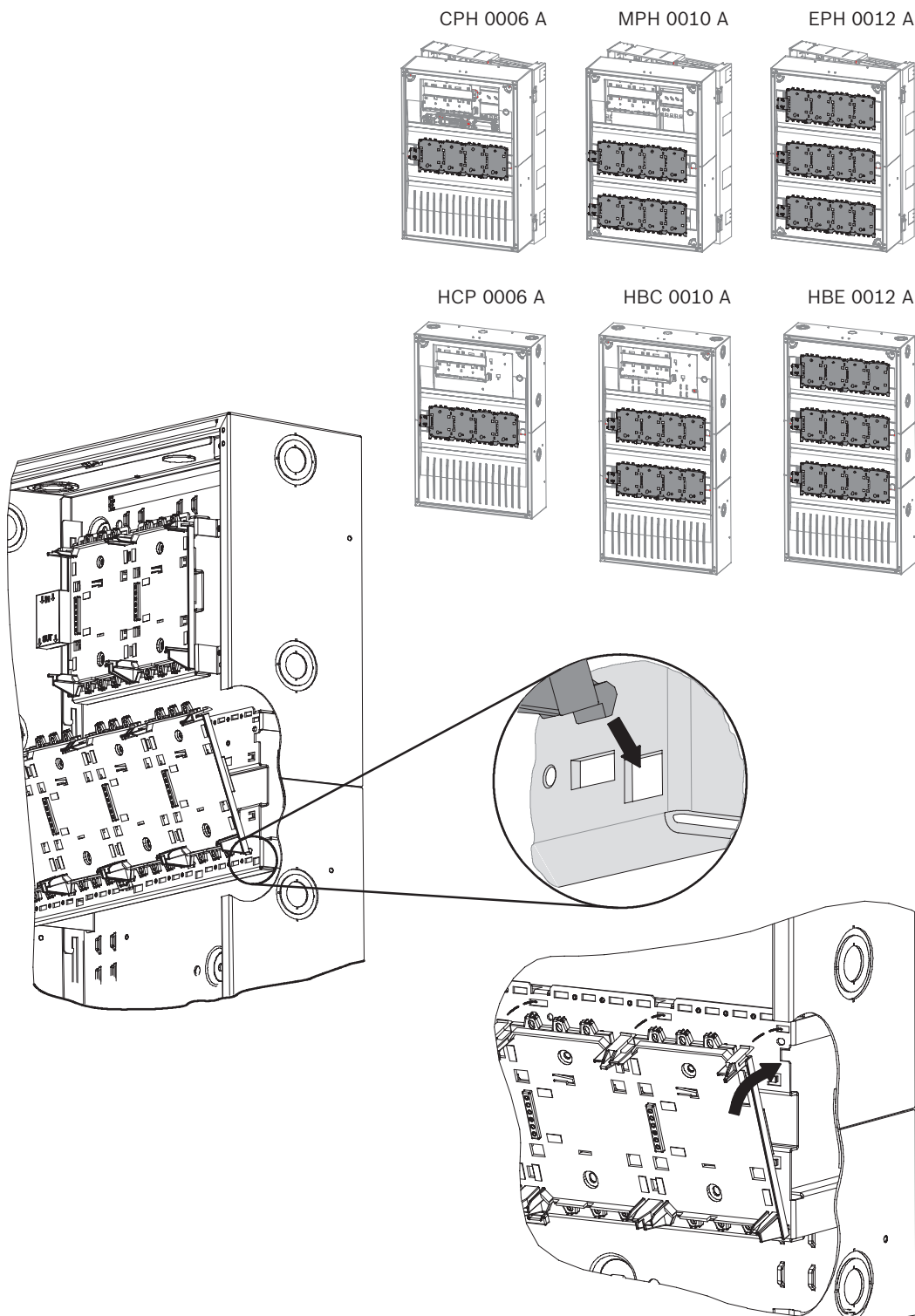

Figure 4.37: PRD 0004 A installation

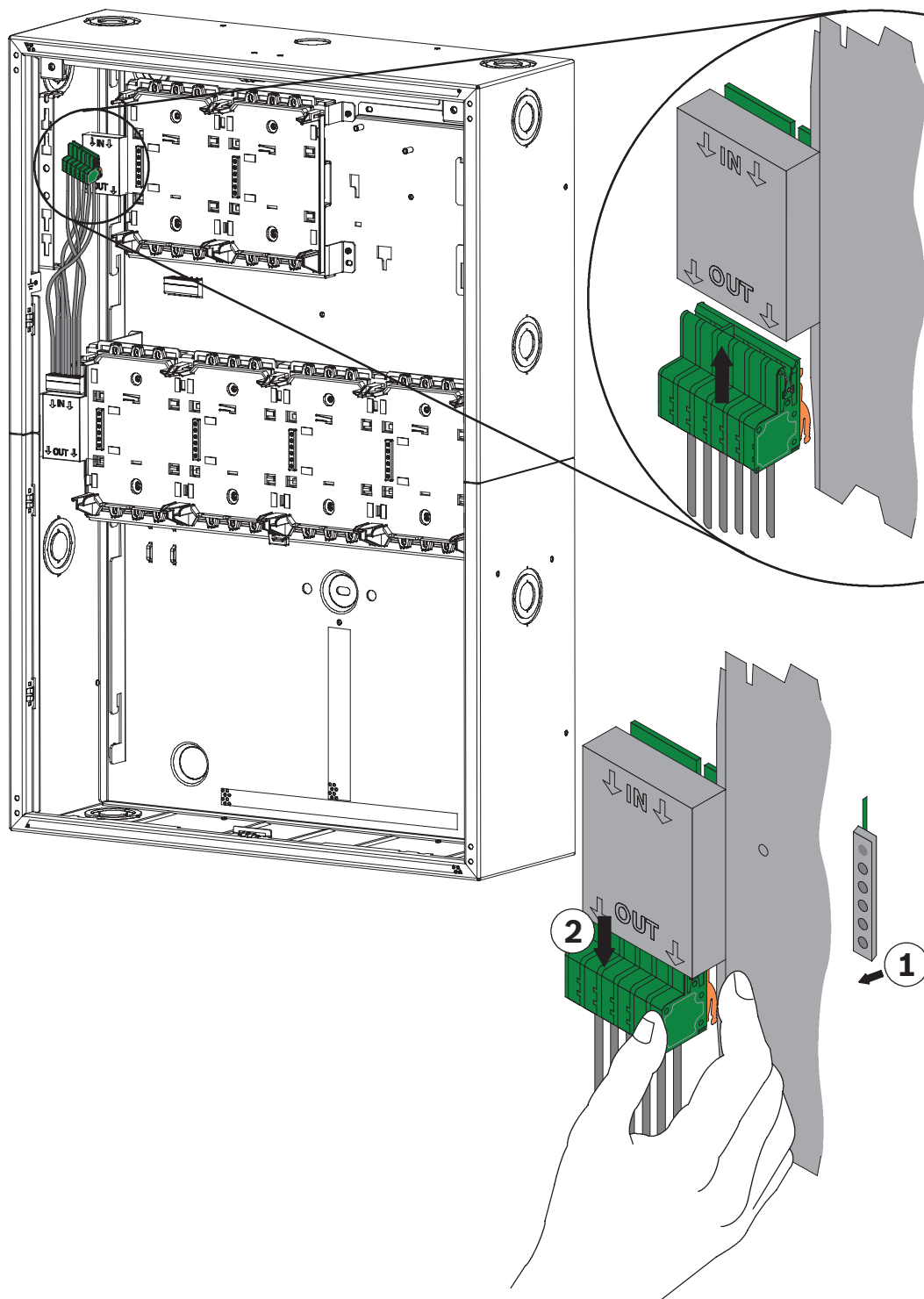

Figure 4.38: Connection of panel rail

4.8

MPC Panel Controller

The panel controller with the operating and display unit is the central element of the fire detection system.



Notice!

Installation must only be performed by authorized and specialized personnel!



Notice!

The DVD includes the FSP-5000-RPS Programming Software and the required product documentation of the panel.

The technical data can be found in *MPC*, page 148.

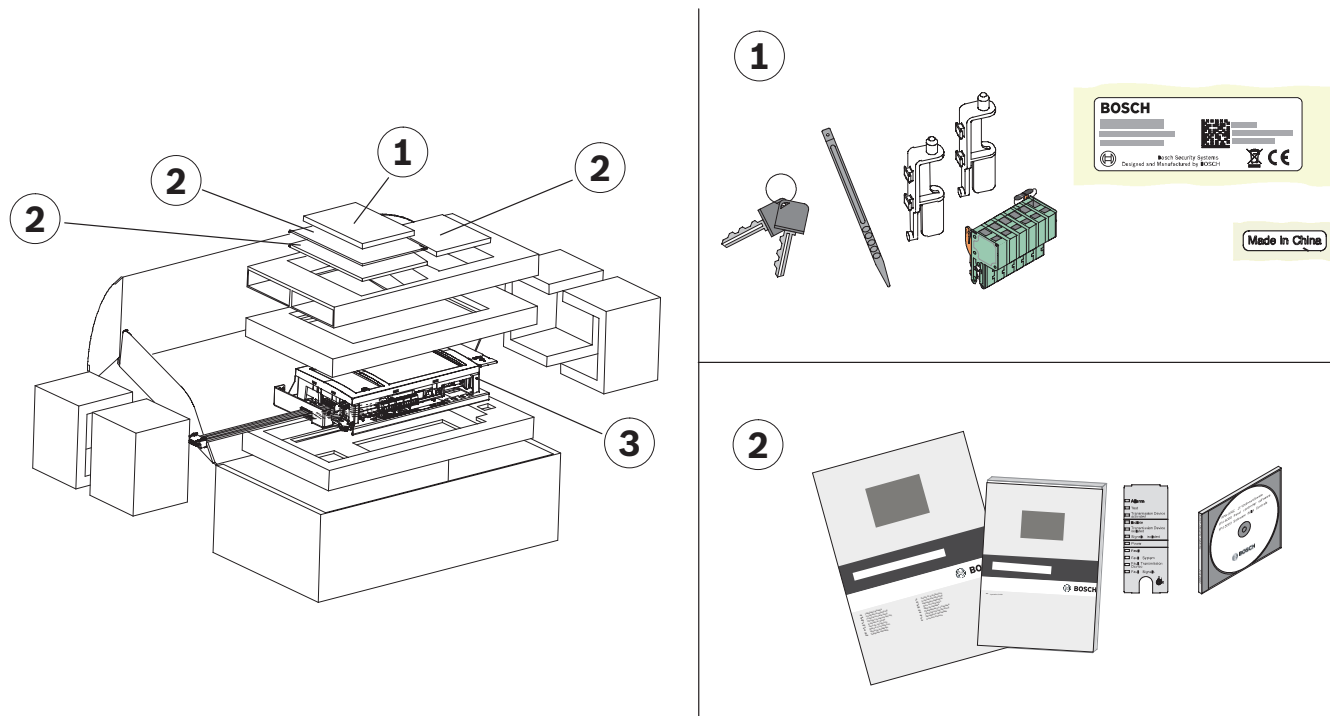

Figure 4.39: Scope of delivery for MPC

Functional Description

The panel controller controls all components in the system and has the following functional elements

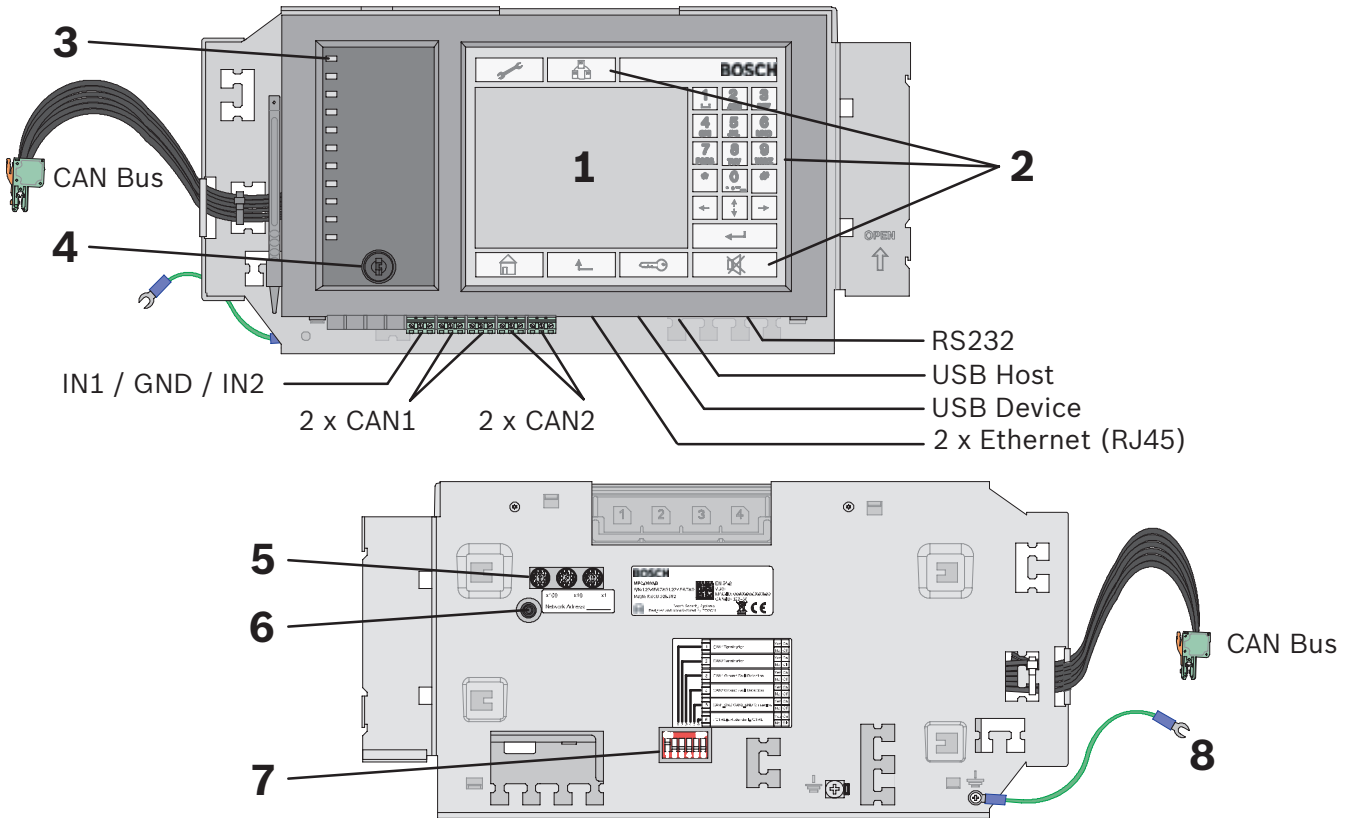

Figure 4.40: MPC functional elements

Position	Designation	Function
1	Touch screen	Operation of the panel using virtual keys and variable display windows
2	22 permanent keys	Standard inputs
3	12 LEDs	Display operating status. The LED strip can be provided with a labeling strip. A country-specific insert strip is enclosed with the operating instructions.
4	Key switch	Two switch positions, freely programmable, e.g. for switching between day/night mode or activating/deactivating local alarms
5	3 rotary switches	Address setting
6	Reboot button	Panel hardware reset
7	6-pin DIP switch	Configuration setting
8	Grounding cable	Panel controller grounding

Networking and Interfaces

The panel controller has

- 2 CAN interfaces (CAN1/CAN2) for networking
- 2 Ethernet interfaces (ETH1/ETH2) for networking
- 2 signal inputs (IN1/IN2)
- 1 USB and 1 RS232 interface

Note the maximum cable length of 2 m for connection to the USB and RS232 interface.

**Notice!**

You will find detailed information about the CAN and Ethernet networking of the panels in the Networking Guide available for download at www.boschsecurity.com.

When connecting to a building management system (BIS) via an OPC server and Ethernet 100BaseTX in multiple building networks, you must clarify with the network administrator whether

1. the network is designed for multiple building connections (e. g. there must be no technical interference due to differences in grounding potential);
2. the bandwidth of the bus users is sufficient for the network.

Information about address setting and configuration in the network can be found in section *Addressing and Settings in the Network, page 96*.

**Notice!**

For detailed information about the installation und configuration of the OPC server see the FSM-5000-OPC-Server manual.

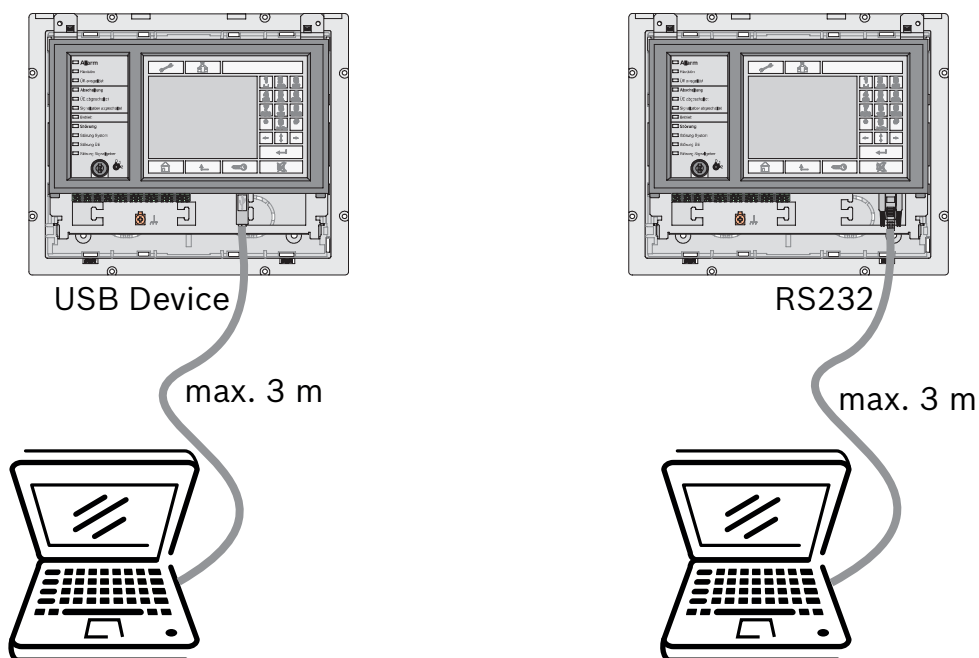

Figure 4.41: MPC, USB and RS232 interfaces

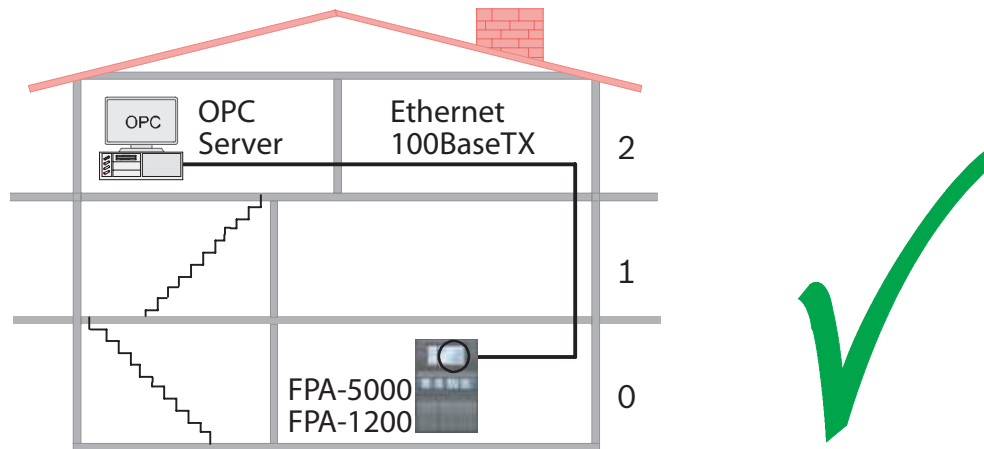

Figure 4.42: MPC connection to BIS via OPC server

Installation

The MPC Panel Controller can be installed in the following housings: CPH 0006 A, MPH 0010 A, HCP 0006 A and HBC 0010 A.

For installation, follow the instructions on the following pages.

Notes:

- Make sure the Panel Rail Short is installed before you install the panel controller.
- Secure the grounding cable at the screw provided on the housing (4).
- Plug the cable into the IN slot on the Panel Rail Short (6).

Caution: Connection at the OUT slot or to a Panel Rail Long is not permissible.

- Plug the terminal element for the data bus into the OUT slot on the last occupied panel rail (8).

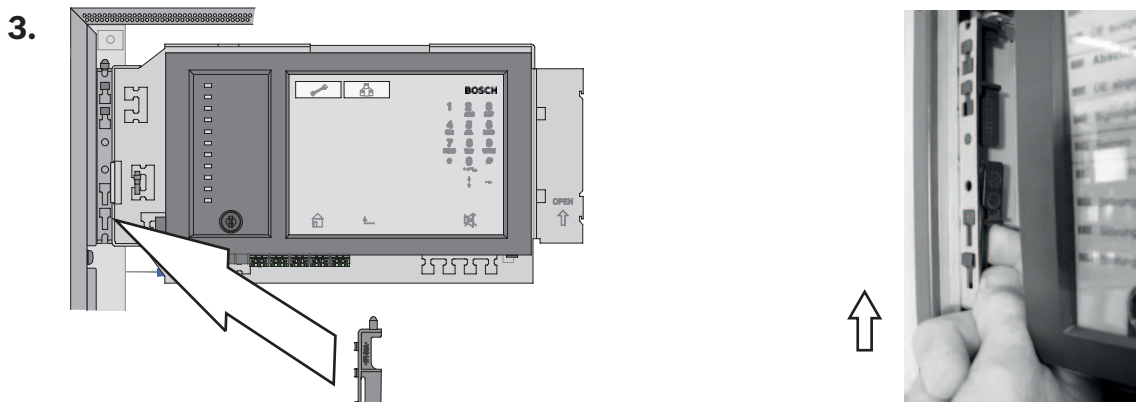
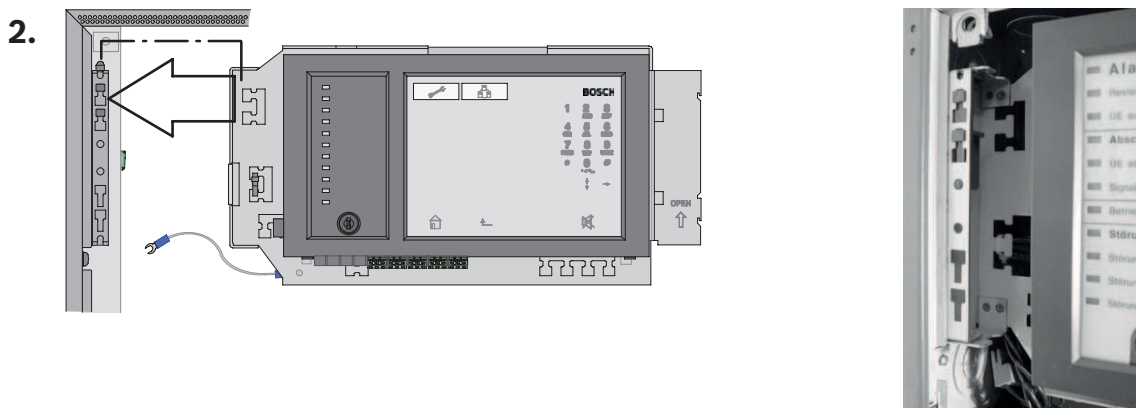
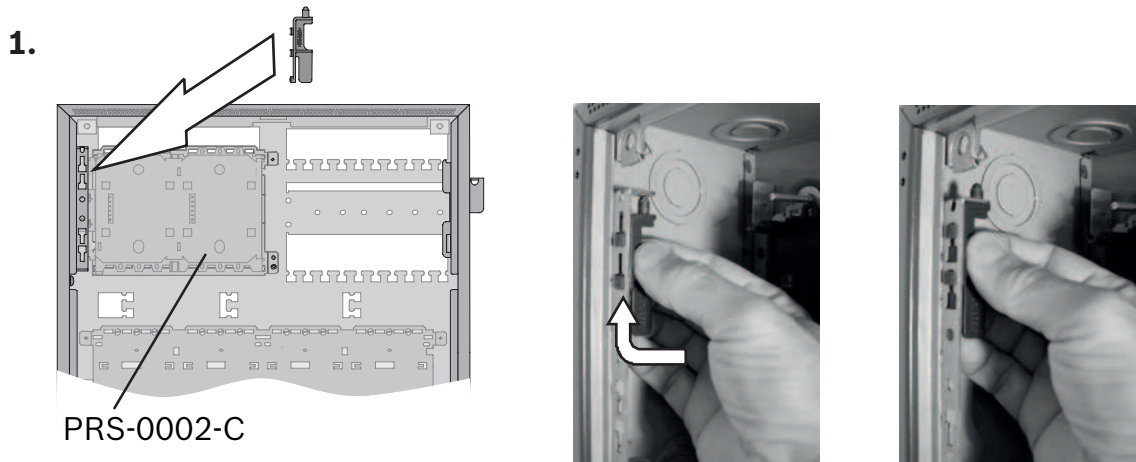
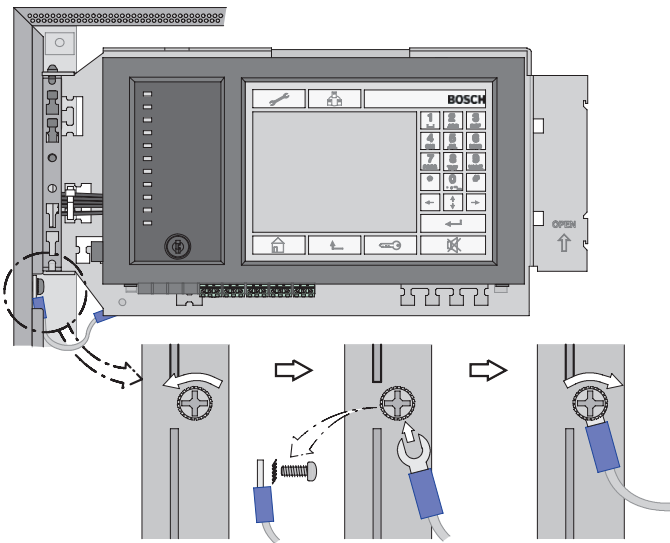
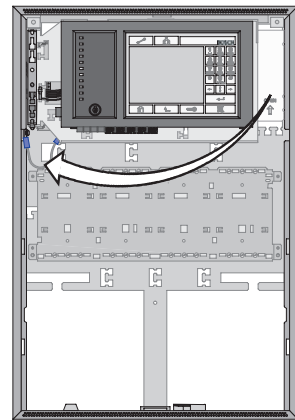

Figure 4.43: MPC installation (1-3)

4.



5.



6.

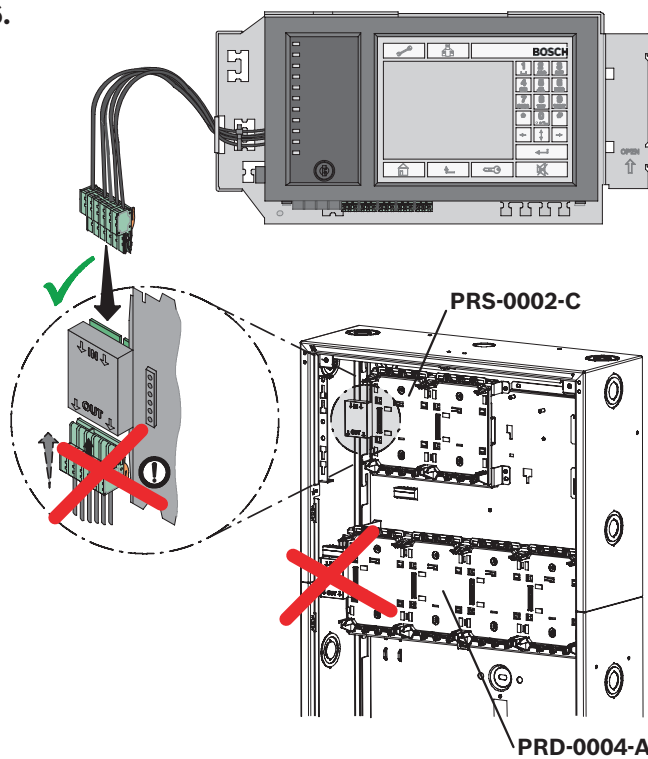
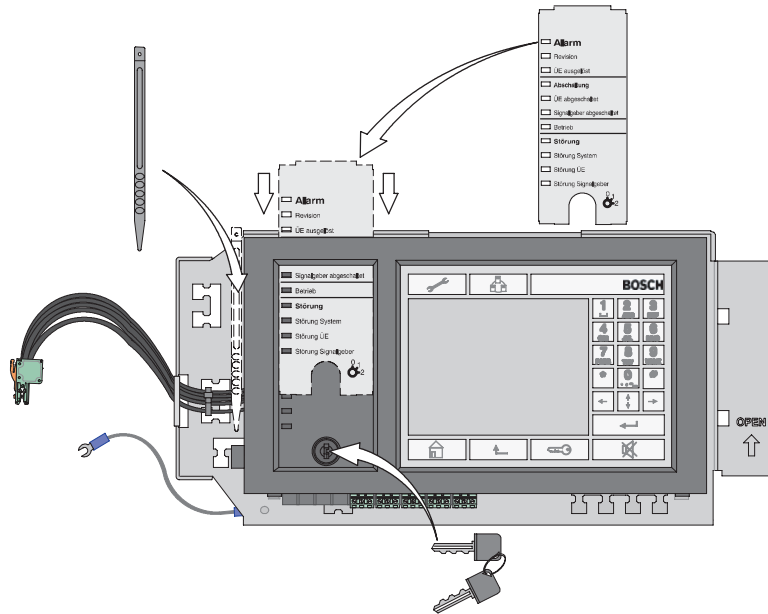
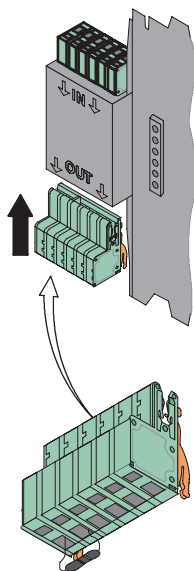

Figure 4.44: MPC installation (4-6)

7.



8.



9.



Figure 4.45: MPC installation (7-9)

Addressing and Settings in the Network

The panels and remote keypads are identified in the network by a unique address. This address is set on the rotary switches and is known as the rotary switch number (RSN) (see the figures in the circle on the circuit diagrams). The rotary switches are located on the rear of the panel controller (see *Addressing and Configuration of MPC Panel Controller*, page 98). Note the address on the sign below the rotary switches (see *Addressing and Configuration of MPC Panel Controller*, page 98, step 2).

The DIP switches are located on the rear of the panel controller (see *Addressing and Configuration of MPC Panel Controller*, page 98).

Mark the selected setting on the sign above the DIP switches (see *Addressing and Configuration of MPC Panel Controller*, page 98, step 4).

**Notice!**

Redundant panels must have identical addresses.

**Notice!**

You will find detailed information about the CAN and Ethernet networking of the panels in the Networking Guide available for download at www.boschsecurity.com.

Addressing and Configuration of MPC Panel Controller

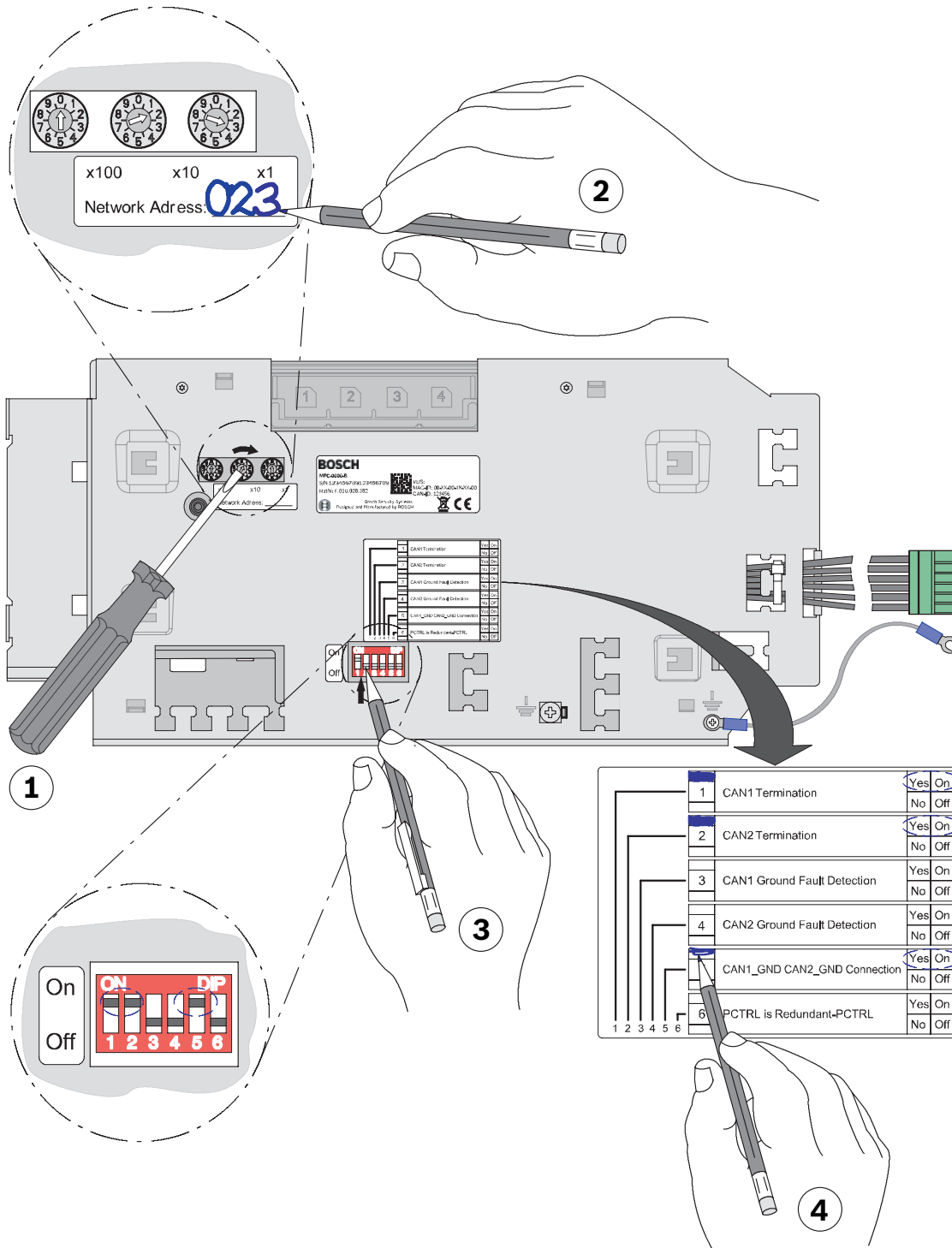

Figure 4.46: MPC Panel Controller, addressing

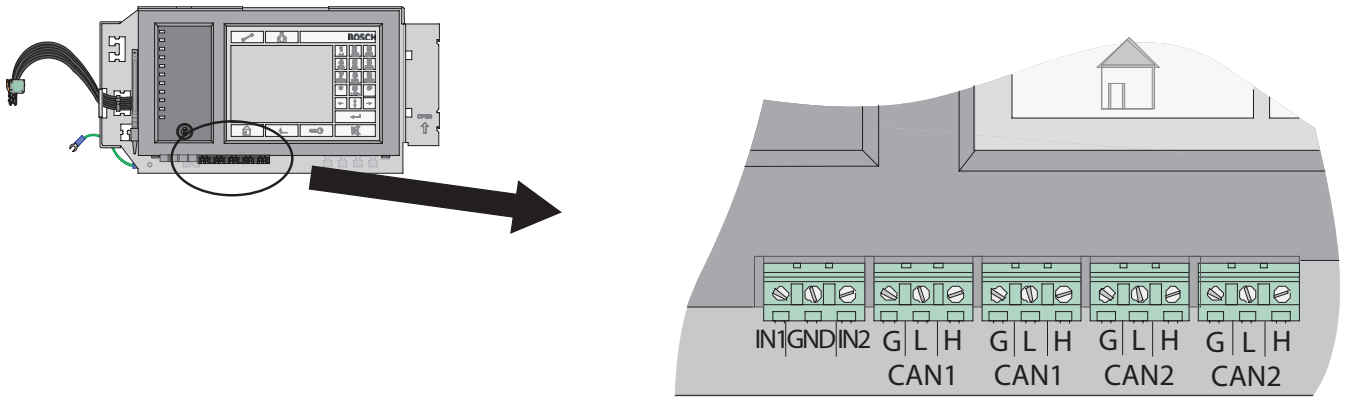

Figure 4.47: MPC Panel Controller, network connections

Standalone Panel (FPA-5000 | FPA-1200) and Redundant Standalone Panel (FPA-5000)

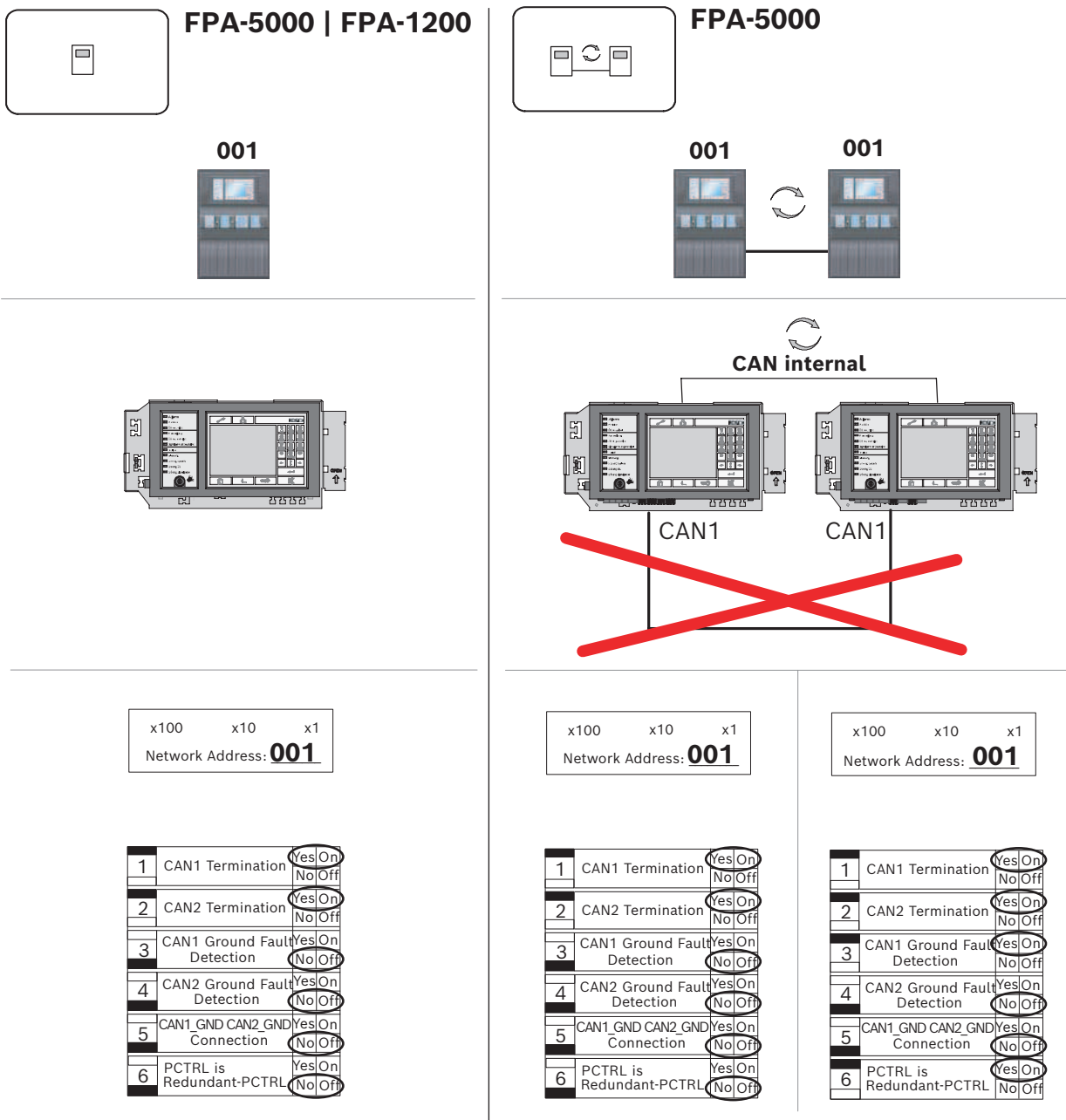

Figure 4.48: Standalone panel (regular and redundant): Configuration in network

4.9 Functional Modules

Each functional module has been developed for a specific function within the fire detection system.

All modules feature:

- robust, totally enclosed housings
- replacement during operation
- pluggable connection terminals
- automatic detection

The plug contacts in the panel rail provide the power supply to the modules and handle all data traffic between the module and control panel.

The module is automatically identified as soon as it is plugged in. Contact with peripheral devices is achieved with compact plug/screw terminals. If a module is replaced, then the plug/screw terminals are simply re-fitted, with no need for complex rewiring.

Functional settings on the modules are made using the FSP-5000-RPS programming software.

4.9.1 Installation and Removal

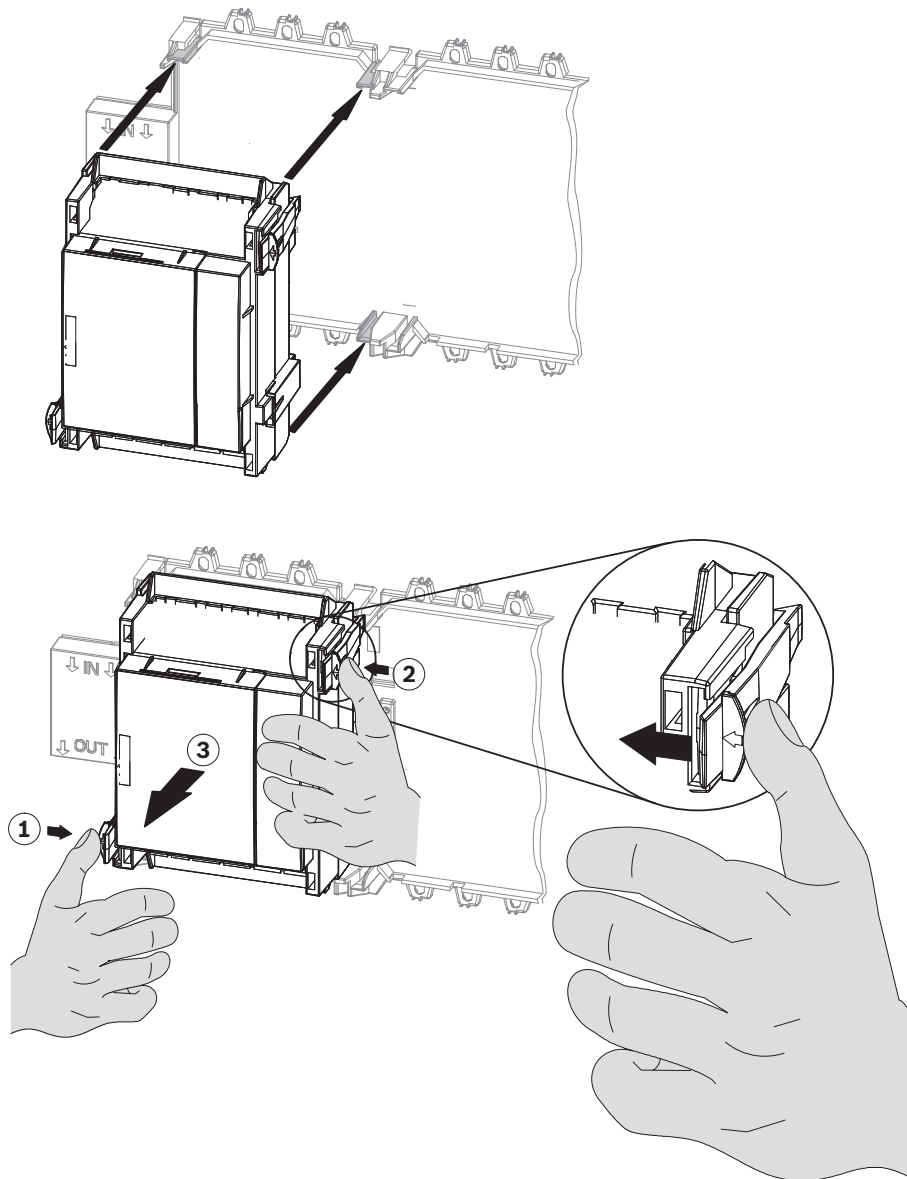

Figure 4.49: Installation and removal of functional modules

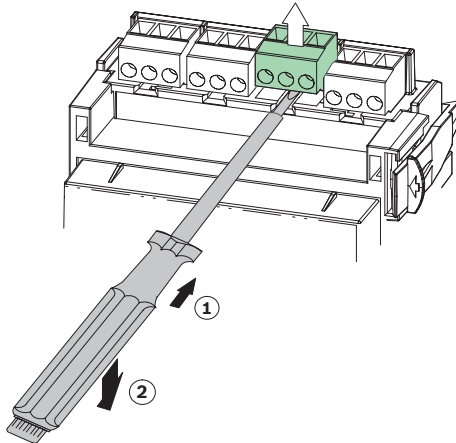

Figure 4.50: Detaching the screw terminal block

4.9.2

ANI 0016 A Annunciator Module

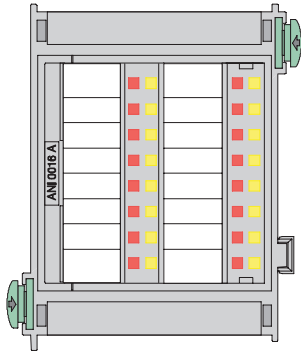

Figure 4.51: ANI 0016 A Annunciator Module

The annunciator module has 16 red and 16 yellow LEDs for displaying the operating states of 16 definable detection points.

The activation of each LED is defined using the FSP-5000-RPS programming software.

This defines which detection points will activate the LEDs in which state.

The technical data can be found in *ANI 0016 A Annunciator Module*, page 150.

4.9.3

BCM-0000-B Battery Controller Module

The BCM-0000-B Battery Controller Module monitors the power supply of the entire panel and regulates the temperature and time-controlled charging of up to four batteries.

The following functions are available using the keys on the module **(1)**:

- The four LEDs on the module light up as a confirmation and LED test each time the key is pressed.
- If the batteries have a voltage of between 18 V and 21 V, the battery charging procedure can be started manually. Please note that a power supply must be available.
- The 24 V switch outputs can be reset.
The switch output is deactivated if a fault occurs.

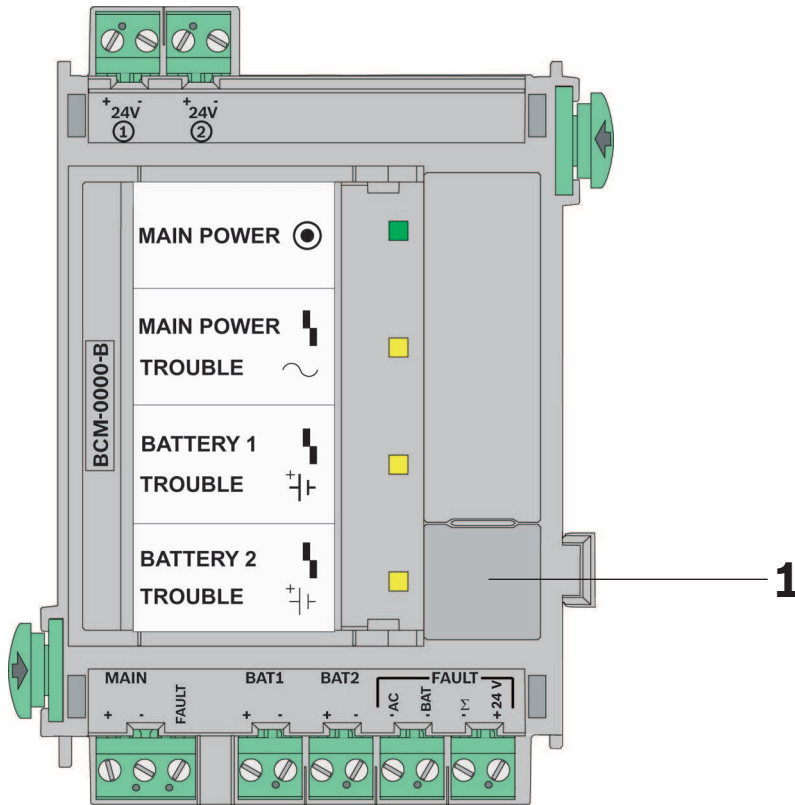

Figure 4.52: BCM-0000-B Battery Controller Module

Top connections, from left to right	
24 V + -	Switch output +24 V max. 2.8 A (battery buffered, optional)
24 V + -	Switch output +24 V max. 2.8 A (battery buffered, optional)
Lower connections, from left to right	
MAIN + -	Power supply unit connection
MAIN FAULT	Signal input for power supply unit fault
BAT1 + -	Battery pair 1 connection
BAT2 + -	Battery pair 2 connection
FAULT AC -	Switch output for mains fault
FAULT BAT -	Switch output for battery fault
FAULTΣ -	Switch output for collective fault
FAULT +24 V	Switch output +

Notes

- The module can only be used with the MPC Panel Controller from software version 2.1 onwards.
- If the fire panel is not supplied with mains power, it can only be started
 - if a battery pair is connected to BAT1 and
 - no second battery pair is connected to BAT2.

If batteries are connected to the BAT2 connection on the module, the system will report a battery fault and will not start. This battery fault can only be reset if the fire panel is supplied with mains power and the BAT 2 connection is configured.

- If the fire panel is not supplied with mains power for an extended period, ensure that the batteries are disconnected.
- When using the module in the FPP-5000 External Power Supply, only one battery pair can be charged (see *FPP-5000 External Power Supply Unit Kit 24 V/6 A*, page 120).
- Refer to the configuration information in *Configuration of BCM Battery Controller Module*, page 43.

The technical data can be found in *BCM-0000-B Battery Controller Module*, page 150.

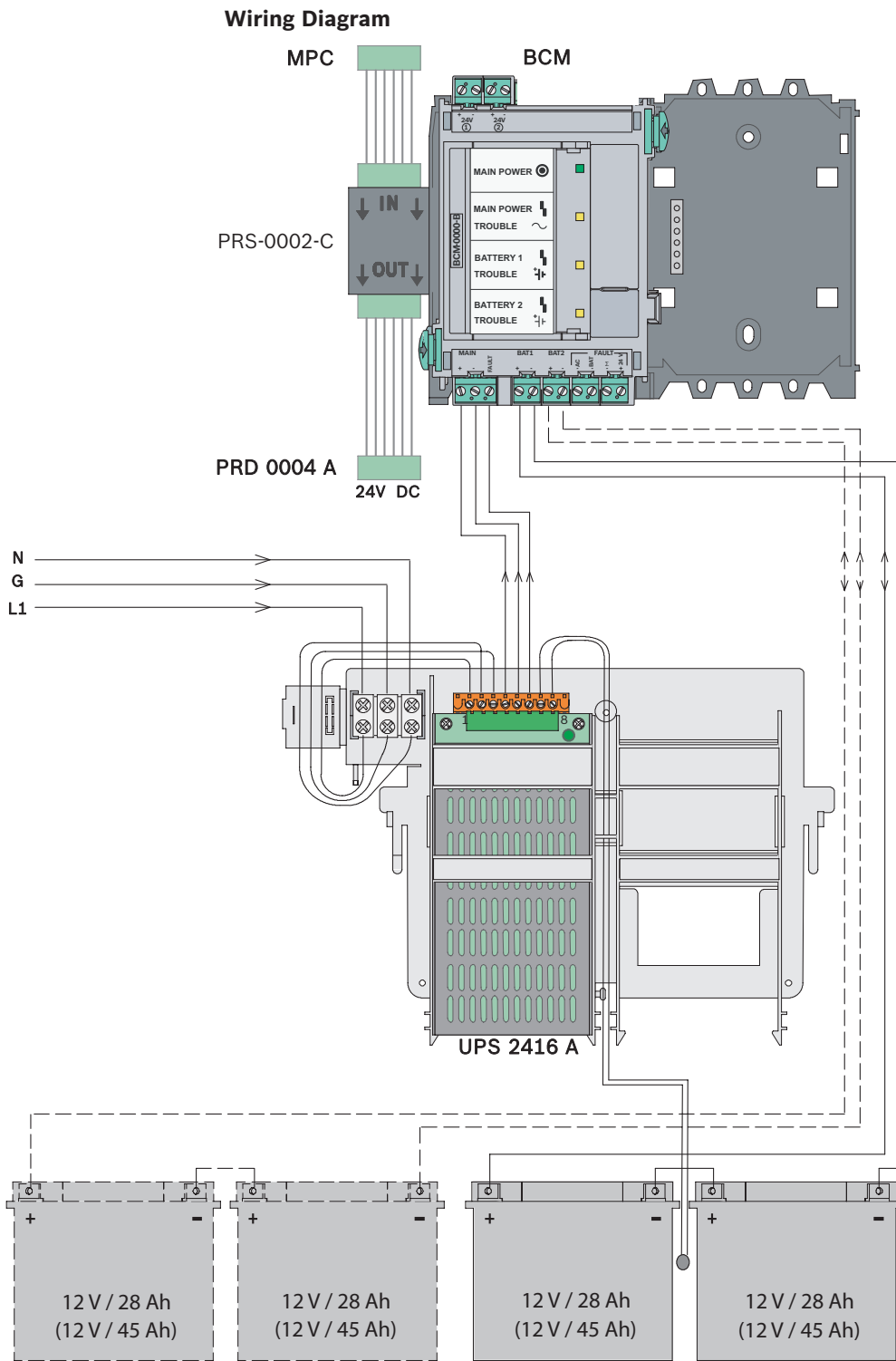

Figure 4.53: Wiring diagram for BCM-0000-B

Battery Connection

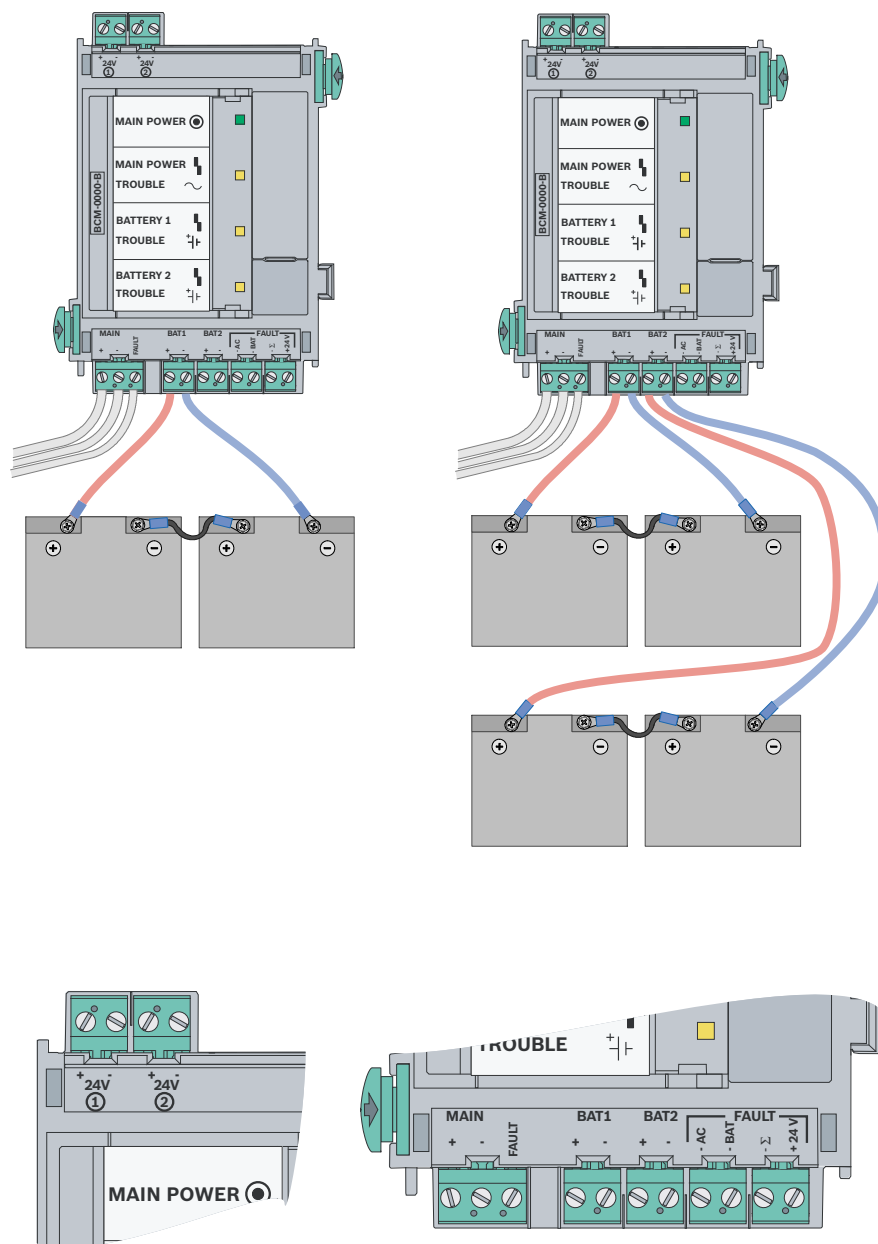

Figure 4.54: BCM-0000-B battery connection

Cable Set

A cable set is supplied and contains 2 connection cables: BCM/battery (90 cm) and battery/battery (17 cm).

If you want to install the batteries in a power supply housing, you require the CBB 0000 A Cable Set (BCM/battery cable length 180 cm).



Warning!

There is a risk of injury if no temperature sensor is positioned between the batteries. The temperature sensor is supplied with the power supply bracket and protects the batteries against overheating. If the sensor is not positioned correctly, the batteries can overheat and explode.

Position the temperature sensor between the batteries.

4.9.4

CZM 0004 A 4 Zone Conventional Module

The CZM 0004 A Conventional Module enables particular existing conventional peripheral devices to be connected. It provides connections for four monitored conventional lines.

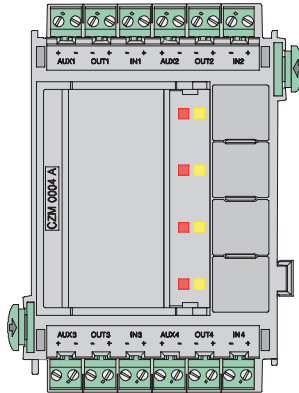

Figure 4.55: CZM 0004 A 4 Zone Conventional Module

Labeling	Connection
AUX1 + AUX1 -	24 V DC auxiliary power supply zone 1
OUT1 - OUT1 +	Zone 1 output low/zone 1 output high
IN1 - IN1 +	Zone 1 input low/zone 1 input high
AUX2 + AUX2 -	24 V DC auxiliary power supply zone 2
OUT2 - OUT2 +	Zone 2 output low/zone 2 output high
IN2 - IN2 +	Class A zone 2 input low/class A zone 2 input high
AUX3 + AUX3 -	24 V DC auxiliary power supply zone 3
OUT3 - OUT3 +	Zone 3 output low/zone 3 output high
IN3 - IN3 +	Class A zone 3 input low/class A zone 3 input high
AUX4 + AUX4 -	24 V DC auxiliary power supply zone 4
OUT4 - OUT4 +	Zone 4 output low/zone 4 output high
IN4 - IN4 +	Class A zone 4 input low/class A zone 4 input high



Notice!

To ensure operation of the fire alarm system with Extended Line Supervision (ELS, creeping short circuit and creeping open monitoring), each conventional line must be terminated with EOL modules.

**Caution!**

Electromagnetic compatibility

Only use 4-wire cabling when connecting the peripherals.

- EOL modules can be used with CZM 0004 A from software version 1.1.10 onwards.
- All additional voltage outputs (AUX 1-AUX 4) can be switched on and off simultaneously.
- Two and four-wire conventional components can be connected.
- Note the maximum line resistance:
 - 25 Ohm for conventional lines with FMC-300RW or automatic fire detectors
 - 12 Ohm for conventional lines with FMC-120-DKM manual call points

The technical data can be found in *CZM 0004 A 4 Zone Conventional Module*, page 151.

4.9.5**ENO 0000 B Fire Service Interface Module**

The ENO 0000 B is used to connect fire service equipment:

- Transmission device to the fire brigade
- Key deposit
- Signal lamp (e.g. BEGA flush-mounting lamp or BL 200)
- FSE release element monitoring
- Four freely programmable changeover relays

**Notice!**

The requirements of the local fire department must be taken into account during programming.

The module is used almost exclusively in Germany.

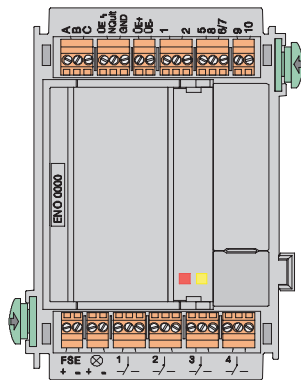

Figure 4.56: ENO 0000 B Fire Service Interface Module

Labeling	Connection
A	Ground
B	Transmission unit control
C	Feedback contact
ÜE	Automatic dialer and transmission unit fault
NQuit	Acknowledge
GND	Ground
ÜE+ ÜE-	Power supply of transmission unit
1	Monitoring key deposit

Labeling	Connection
2	Ground
5	Door release magnet, +12 V/24 V, approx. 10 W
8	Key deposit lock monitoring
6 7	Ground
9	Heating, +24 V, approx. 8 W
10	Ground
FSE+ -	FSE release element monitoring
⊗ + -	Signal lamp, e.g. BEGA lamp +24 V, approx. 10 W
$\frac{x}{-}$	Relay 1-4

Information on the redundant connection of the module can be found in *Redundancy, page 34*. The technical data can be found in *ENO 0000 B Fire Service Interface Module, page 151*.

4.9.6

FPE-5000-UGM Interface Module

The FPE-5000-UGM Interface Module allows the stand alone fire panel or the panel network to be connected to a higher-level system such as the UGM or to fire service devices such as FMF-FAT/FMF-FBF-FAT. The module provides two bi-directional transmission paths.

The module has two LEDs per transmission path for indicating the status (green = transmission, yellow = fault), and a key for testing the LEDs.

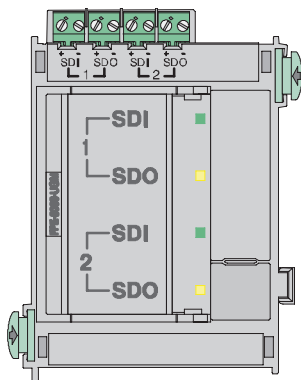

Figure 4.57: FPE-5000-UGM Interface Module

Labeling	Connection	
SDI 1 + -	Transmission path 1	Data input + -
SDO 1 + -		Data output + -
SDI 2 + -	Transmission path 2	Data input + -
SDO 2 + -		Data output + -

Information on the redundant connection of the module can be found in *Redundancy, page 34*. The technical data can be found in *FPE-5000-UGM Interface Module, page 152*.

4.9.7

IOP 0008 A Input/Output Module

The IOP 0008 A Input/Output Module has 8 independent digital inputs and 8 open collector outputs for individual displays or for flexible connection of various electrical devices.

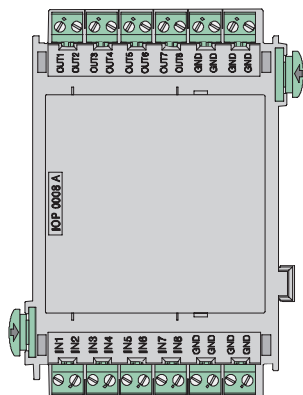

Figure 4.58: IOP 0008 A Input/Output Module

Labeling	Connection
OUT1-OUT8	Outputs, max. voltage of 35 V DC at 1.5 A per output (nominal 0.7 A)
GND	Ground
IN1-IN8	Inputs, max. voltage of 5 V DC at 0.1 mA per input
GND	Ground

The technical data can be found in *IOP 0008 A Input/Output Module*, page 152.

4.9.8

IOS 0020 A 20 mA Communication Module

The 20 mA communication module has an S1 interface, an RS232 interface (e.g. for connecting a printer) and an S20 interface (20 mA). The FAT 2002 Fire Service Display Panel or the THP 2020 A Thermal Printer is connected to the S20 interface. The Plena Voice Alarm System can be connected via the RS232 interface.

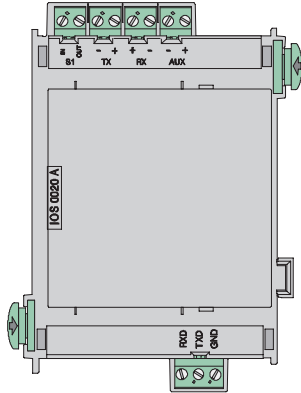

Figure 4.59: IOS 0020 A 20 mA Communication Module

Labeling	Connection
S1 IN S1 OUT	S1 interface
TX - TX + RX + RX -	S20 interface (20 mA interface)
AUX - AUX +	Power supply +24 V DC/max. 1.3 A
RXD TXD GND	RS232 interface

Assignment of DSUB 9 Plug



Figure 4.60: DSUB 9 plug

PIN no.	Connection
2	TxD0
3	RxD0
5	GND

The technical data can be found in *IOS 0020 A 20 mA Communication Module*, page 152.

4.9.9

IOS 0232 A RS232 Communication Module

The module has two independent serial interfaces, which can be used to connect two devices, e.g. a Plena Voice Alarm System, laptop or printer.

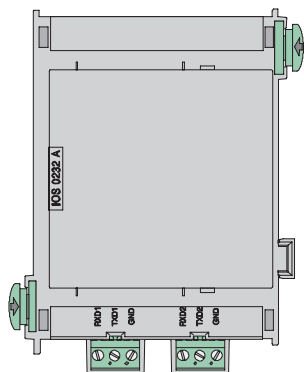

Figure 4.61: IOS 0232 A RS232 Communication Module

Labeling	Connection
RXD1 TXD1 GND	RS232 interface 1
RXD2 TXD2 GND	RS232 interface 2

Assignment of DSUB 9 Plug

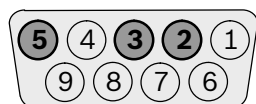

Figure 4.62: DSUB 9 plug

PIN no.	Connection
2	TxD0
3	RxD0
5	GND

The technical data can be found in *IOS 0232 A RS232 Communication Module, page 152*.

4.9.10

LSN 0300 A LSN improved Module 300 mA

This module enables an LSN loop with up to 254 LSN improved elements or 127 classic LSN elements to be connected, with a maximum line current of 300 mA and a cable length of up to 1600 m (depending on configuration and cable type).



Notice!

To ensure that the fire detection system is operated in compliance with EN 54-13, each LSN stub and T-tap must be terminated with EOL modules.

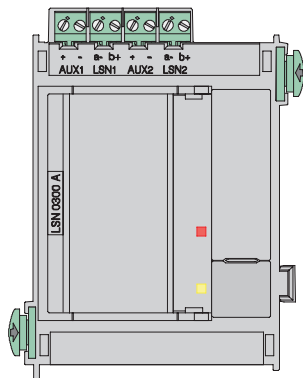

Figure 4.63: LSN 0300 A LSN improved Module 300 mA

Labeling	Connection	
	LSN loop	LSN stub
AUX1 + AUX1 -	Auxiliary power supply	Auxiliary power supply for stub 1
LSN a1- LSN b1+	LSN a1- / LSN b1+ outgoing	Stub 1 LSN a1- / Stub 1 LSN b1+
AUX2 + AUX2 -	Auxiliary power supply*	Auxiliary power supply for stub 2
LSN a2- LSN b2+	LSN a2- / LSN b2+ incoming	Stub 2 LSN a2- / Stub 2 LSN b2+
* The auxiliary voltage may only be fed back to AUX2 when isolators (ERT technology) are used in the loop (suitable components include YBO-R/SCI isolators).		

The technical data can be found in *LSN 0300 A LSN improved Module 300 mA*, page 153.

4.9.11

LSN 1500 A LSN improved Module 1500 mA

This module can be used to connect an LSN loop with

- up to 254 LSN improved elements with a max. line current of 1500 mA and a cable length of up to 3000 m (depending on configuration and cable type)
- up to 127 classic LSN elements with a max. line current of 300 mA and a cable length of up to 3000 m (depending on configuration and cable type).



Caution!

The module may only be connected to a PRD 0004 A Panel Rail Long, where it requires two slots (see *Installation in Panel Rail*, page 114).

The module must be connected to the first two slots on the left of the panel rail.



Notice!

To ensure that the fire detection system is operated in compliance with EN 54-13, each LSN stub and T-tap must be terminated with EOL modules.

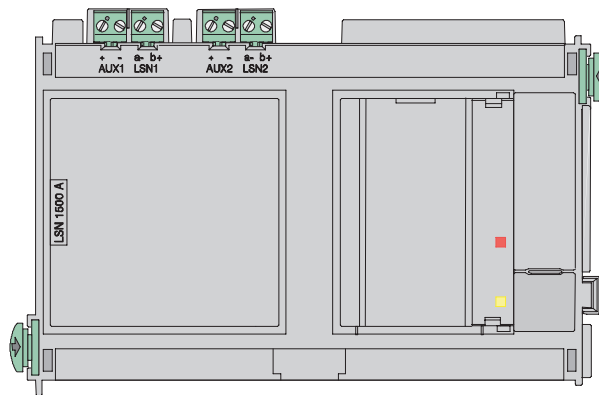

Figure 4.64: LSN 1500 A LSN improved Module 1500 mA

Labeling	Connection	
	LSN loop	LSN stub
AUX1 + AUX1 -	Auxiliary power supply	Auxiliary power supply for stub 1
LSN a1- LSN b1+	LSN a1- / LSN b1+ outgoing	Stub 1 LSN a1-/stub 1 LSN b1+
AUX2 + AUX2 -	Auxiliary power supply*	Auxiliary power supply for stub 2
LSN a2- LSN b2+	LSN a2- / LSN b2+ incoming	Stub 2 LSN a2-/stub 2 LSN b2+
* The auxiliary voltage may only be fed back to AUX2 when isolators (ERT technology) are used in the loop (suitable components include YBO-R/SCI isolators).		

The technical data can be found in *LSN 1500 A LSN improved Module 1500 mA*, page 153.

Installation in Panel Rail

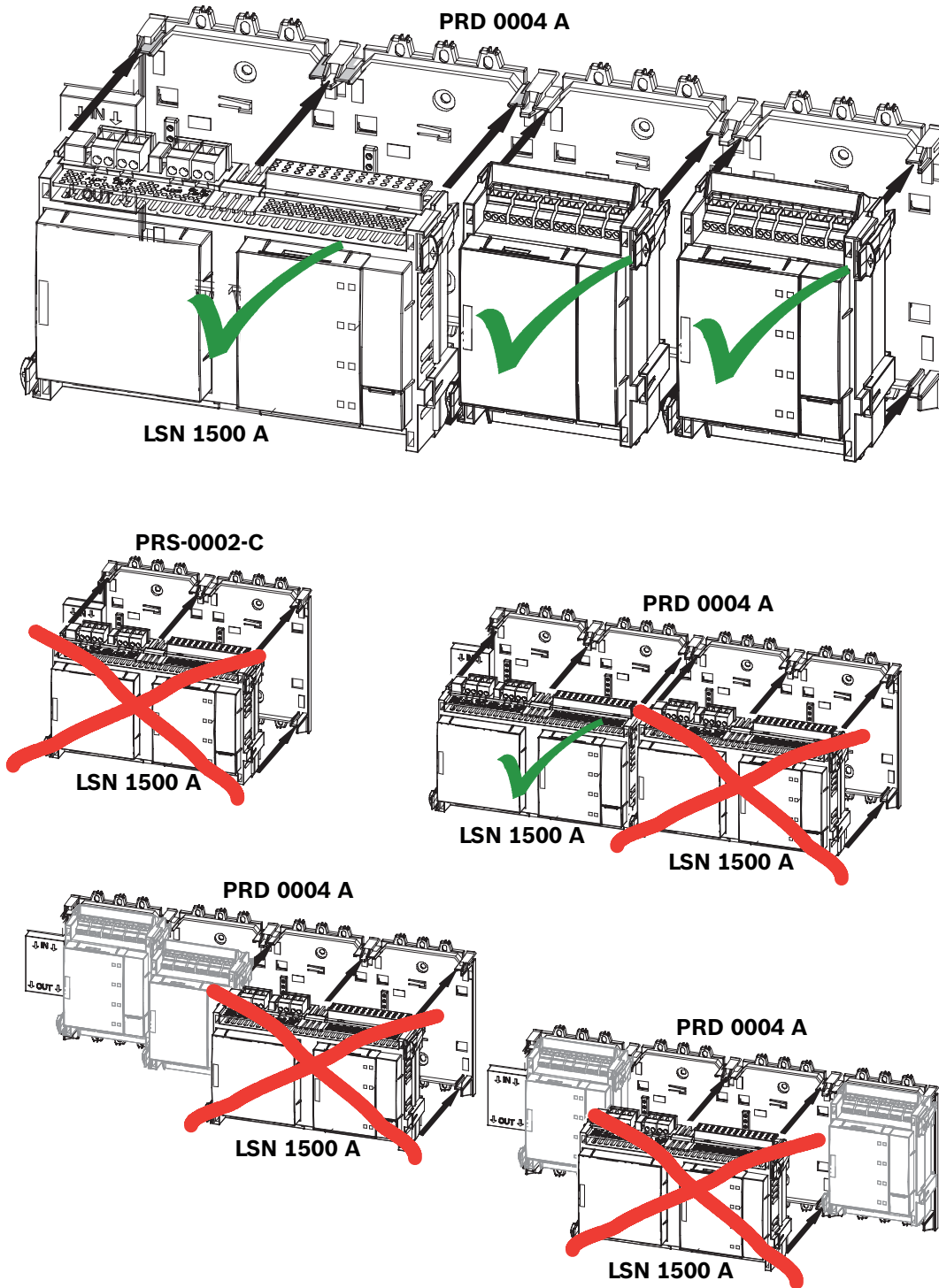

Figure 4.65: LSN 1500 A - Inserting the module

4.9.12

NZM 0002 A Notification Appliance Zone Module

The NZM 0002 A Notification Appliance Zone Module provides two monitored primary lines. This enables the connection of two separate notification appliance lines.

The following can be connected:

- Sounders
- Strobes
- Horns

The operating status of each zone is shown by a red and a yellow status LED.

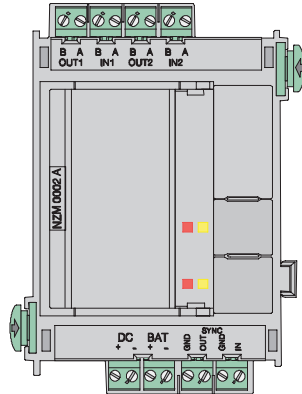

Figure 4.66: NZM 0002 A Notification Appliance Zone Module

Labeling	Connection
B OUT1 A OUT1 B IN1 A IN1	NAC zone 1
B OUT2 A OUT2 B IN2 A IN2	NAC zone 2
DC + DC -	External power supply
BAT + BAT -	24 V DC input, battery voltage
SYNC GND SYNC OUT	Output synchronization
SYNC GND SYNC IN	Input synchronization

The technical data can be found in *NZM 0002 A Notification Appliance Zone Module*, page 154.

4.9.13 RMH 0002 A Relay Module for Mains Voltage



Danger!

The device contains live components.
 Touching live components entails a risk of death or serious injury.
 Disconnect the power supply before all installation work.

The module has two changeover contact relays (type C) for monitored connection of external elements with feedback, e.g.

- Electromagnetic door holders
- Fans
- Smoke dampers

Each relay has one NO (normally open) and one NC (normally closed) contact and is protected by a 6.3 A fuse.

The outputs are not monitored.

The maximum permissible contact load is 5 A at 120 V/230 V AC and 5 A at 30 V DC.

The relay module can also be used as an extinguishing system interface in accordance with VdS 2496.

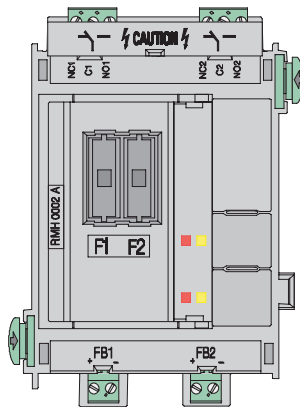

Figure 4.67: RMH 0002 A Relay Module for mains voltage

Labeling	Connection
NC1 C1 NO1	Relay 1
NC2 C2 NO2	Relay 2
FB1 + FB1 -	Feedback relay 1
FB2 + FB2 +	Feedback relay 2

The technical data can be found in *RMH 0002 A Relay Module for mains voltage*, page 154.

4.9.14

RML 0008 A Relay Module for Low Voltage

Relay module for low voltage with eight changeover relays (type C relays) for connecting external elements e.g. notification appliances, smoke dampers etc.

Each relay has one NO (normally open) and one NC (normally closed) contact.

The maximum permissible contact load is 30 V DC/1 A.

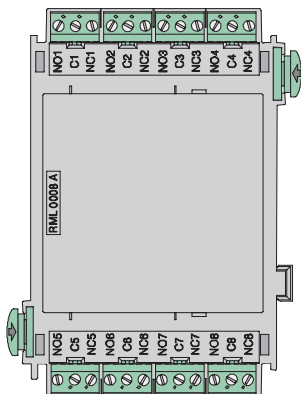
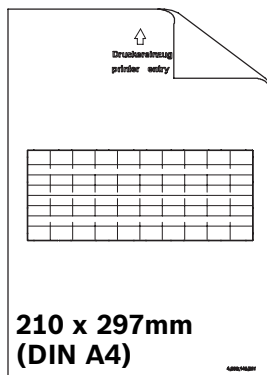

Figure 4.68: RML 0008 A Relay Module for Low Voltage

Labeling	Connection
NO1 C1 NC1	Relay 1
NO2 C2 NC2	Relay 2
NO3 C3 NC3	Relay 3
NO4 C4 NC4	Relay 4
NO5 C5 NC5	Relay 5
NO6 C6 NC6	Relay 6
NO7 C7 NC7	Relay 7
NO8 C8 NC8	Relay 8

The technical data can be found in *RML 0008 A Relay Module for Low Voltage*, page 155.

4.9.15

Accessories for Functional Modules**PSL 0001 A Labeling Strips, Small****Figure 4.69:** PSL 0001 A Labeling Strips, Small

The PSL 0001 A Labeling Strips, Small can only be used for the ANI 0016 A Annunciator Module.

The strips can be individually printed using a standard laser printer. A DOT file is included on the DVD supplied with the panel controller.

Scope of delivery: 20 sheets of 10 strips.

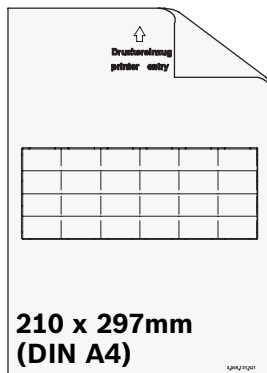
PSK 0001 A Labeling Strips, Wide**Figure 4.70:** PSK 0001 A Labeling Strips, Wide

DIN A4 paper with pre-punched blank labeling strips for the function keys on the modules.

Each sheet contains 6 labeling strips.

The PSK 0001 A Universal Labeling Strips can be used in the following functional modules:

BCM-0000-B, CZM 0004 A , ENO 0000 B , LSN 0300 A, LSN 1500 A, NZM 0002 A, RMH 0002 A

The strips can be individually printed using a standard laser printer. A DOT file is included on the DVD supplied with the panel controller.

Scope of delivery: 20 sheets of 6 strips.

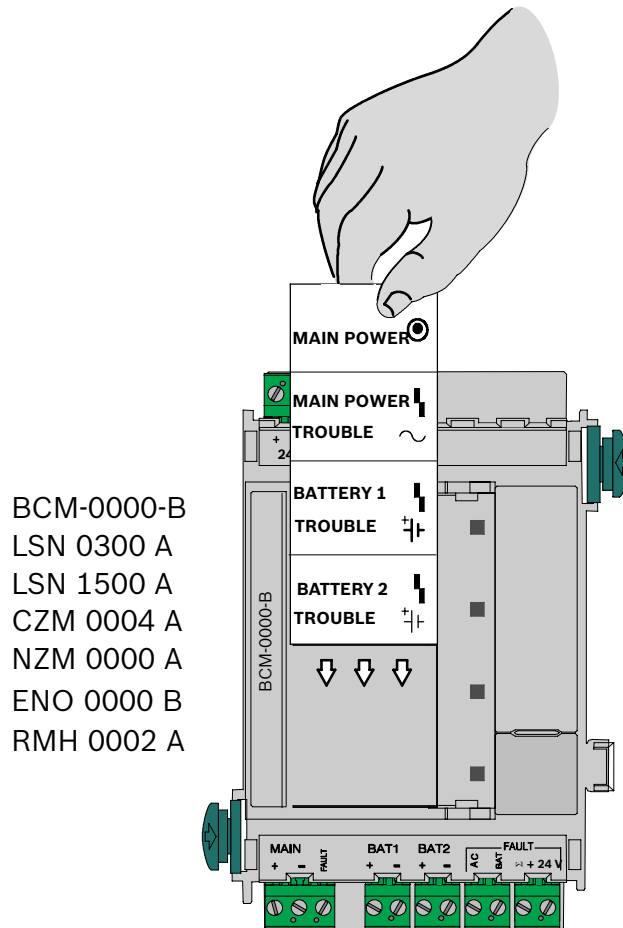

Figure 4.71: PSK 0001 A - Inserting the labeling strip

FDP 0001 A Dummy Cover Plate

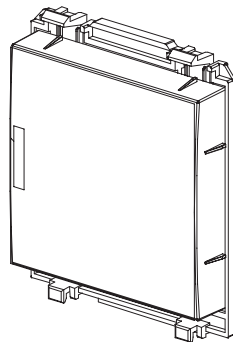

Figure 4.72: FDP 0001 A Dummy Cover Plate

Fit the dummy cover plates on unused module slots in the front panels of the housings.

4.10

Cable Sets

Overview

There are various cable sets available for connecting the central components. All cable sets are supplied with installation instructions ex works. You can also find the installation instructions at www.boschsecurity.com by searching for the type designation of the product. The document numbers of the installation instructions can be found in the footer on every page of the document. The table below shows the instructions available.

Type designation	Connection of to	Document number
CBB 0000 A 1)	BCM Battery Controller Module	Battery pair	F.01U.003.099
CPA 0000 A	MPC Panel Controller	FMA-AT 2000-IP/-ISDN/-GSM, ENO 0000 B	F.01U.003.343
CPB 0000 A	BCM Battery Controller Module	UPS Universal Power Supply	F.01U.003.098
CPR 0001 A	MPC Panel Controller	RLE 0000 A Junction Board	F.01U.003.342
CRP 0000 A	MPC Panel Controller	MPC Panel Controller (Redundant)	F.01U.003.097

1) Required for power supply in a separate power supply housing. Compared to the enclosed standard cable sets, this cable set has a longer connecting cable to the battery.



Notice!

In the installation instructions for the CPA 0000 A Cable Set: Please refer to the programming instructions for the FMA-AT 2000-IP/-ISDN/-GSM.

4.11 Extended line monitoring (VdS 2540, VdS 2543)

Auxiliary power supplies to the following modules can be monitored for creeping short circuits and creeping open: LSN 0300 A, LSN 1500 A, and BCM-0000-B (when using FPP-5000-TI13). A creeping short circuit is detected by these modules. An FPP-5000-TI13 forwards the faults detected and reported by the BCM-0000-B to the panel. Use additional 4-wire end of line elements to monitor for creeping open.

Procedure:

1. Monitor with 4-wire end of line element:
 - On stub cabling, terminate the exposed end of an AUX line with an FLM-420-EOL4W
 - Insert an FLM-420-EOL4W as the last element of an LSN ring or of a stub
 - Use an FLM-320-EOL4W-S for the conventional zone of a conventional zone module or a FLM-420/4-CON
2. In FSP-5000-RPS, activate operation with extended line monitoring (formerly EN 54-13 requirement, now VdS 2540 and VdS 2543 requirement).



Notice!

VdS 2540, VdS 2543

For extended line monitoring (creeping short circuit and creeping open monitoring), no branch wiring is permitted for auxiliary power supplies.

4.12 FPP-5000 External Power Supply Unit Kit 24 V/6 A

The FPP-5000 External Power Supply Unit Kit is designed to provide a universal power supply, and has space for two 12 V/45 Ah batteries.

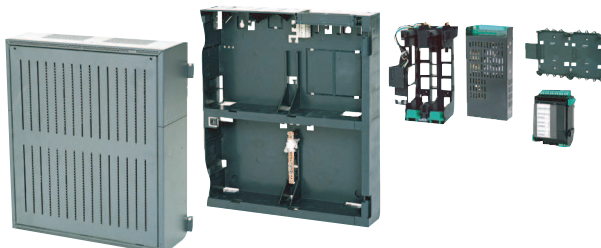

Figure 4.73: FPP-5000 External Power Supply Unit Kit 24 V/6 A

Scope of Delivery

- PMF 0002 A Power Supply Housing Frame Installation medium
- FMH 0000 A Mounting Frame Medium
- Power supply bracket, installed
- UPS 2416 A Universal Power Supply
- PRS-0002-C Panel Rail Short
- BCM-0000-B Battery Controller Module
- Requisite cable sets

Can be Extended with:

- 2 x 12 V/45 Ah batteries
- FPP-5000-TI Trouble Interface or FPP-5000-TI13 LSN Communication Interface
- FPO-5000-EB Earth Bar

Notes

- You can find the installation instructions for the FPP-5000 kit at www.boschsecurity.com by searching for the type designation (document number for installation instructions: F.01U.005.065).
- The installation dimensions are the same as those for the PMF 0004 A with FMH 0000 A Mounting frame.

FPP-5000-TI Trouble Interface

The FPP-5000-TI module is used in the FPP-5000 External Power Supply Unit with the BCM-0000-B to transmit faults to the fire panel via the Local Security Network (LSN).

Two independent signal inputs for "battery fault" and "mains current fault" allow a specified fault indication on the fire panel.

The FPP-5000-TI is connected directly to the LSN bus line and supplied with power via the bus line.

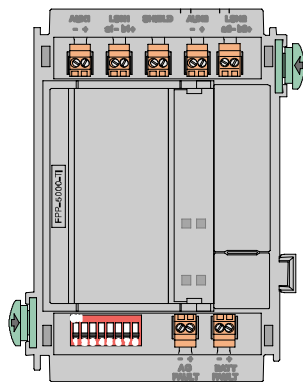

Figure 4.74: FPP-5000-TI Trouble Interface

Labeling	Connection
AUX1 - AUX1 +	Auxiliary power supply, incoming
LSN1 a1 - LSN1 b1 +	LSN in
SHIELD	Shield wire
AUX2 - AUX2 +	Auxiliary power supply, outgoing (support points for looping through)
LSN1 a2 - LSN1 b2 +	LSN outgoing
AC FAULT - +	Input of mains fault

Labeling	Connection
BATT FAULT - +	Input of battery fault

You can find the installation instructions for the FPP-5000-TI module at www.boschsecurity.com (document number for installation instructions: F.01U.081.396). The technical data can be found in *FPP-5000-TI Trouble Interface*, page 156.

FPP-5000-TI13 Communication Interface

The Communication Interface is an extension for the External Power Supply Unit Kit only. It is the communication interface between the External Power Supply Unit Kit and the panel, and transmits the following faults to the panel:

- Mains fault
- Battery fault
- Battery internal resistance fault
- BCM Battery Controller Module fault
- Short 24 V outputs
- Ground fault

Additionally, with the programming software, the switching outputs can be programmed and the settings for extended line monitoring can be done.

Refer to

- *Installation Dimensions for PMF 0004 A with FMH 0000 A Mounting Frame*, page 59

4.13

THP 2020 A Thermal Printer

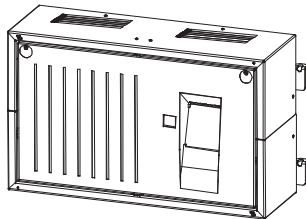

Figure 4.75: THP 2020 A Thermal Printer

Scope of Delivery

- Sheet steel housing, painted
- Thermal printer (installed), with connection cable
- Plastic front panel
- Accessories pack with installation materials

Required for Installation

- FSH 0000 A Mounting Frame Small, or
- FRS 0019 A Rack Installation Kit, Small

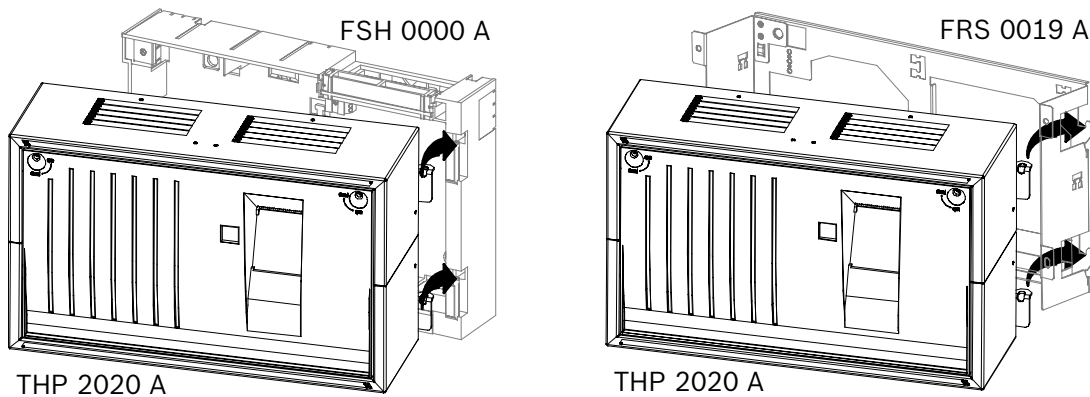

Figure 4.76: THP 200 A mounting frame/installation kit

General Information

- The following information can be sent to the printer:
 - Operating procedures on the panel (e.g. daytime operation)
 - Alarm and fault messages
 - Plain text; programming is carried out via the programming software FSP-5000-RPS.
- On every printout:
 - The current date and the time are specified.
 - The most recent event is always at the top
- Entries stored in the history log can also be printed if the operator has the appropriate operational authorization.
- Always ensure the printer cover panel is closed properly. If the device contact is opened, incoming messages cannot be printed, even at a later date, as the printer does not have its own message memory. In this case, the message only appears on the display of the control panel.
- If the supply of paper is nearing its end, this is indicated by a message on the display of the control panel. When this message appears, you still have enough paper on the roll to print approx. 200 lines of text.

Printer Settings using Jumpers

Notes:

- The jumpers BR2, BR3 and BR4 must not be inserted if connecting to the fire panel.
- Caution: Inserting jumper BR1 changes the character set from Western to Cyrillic.

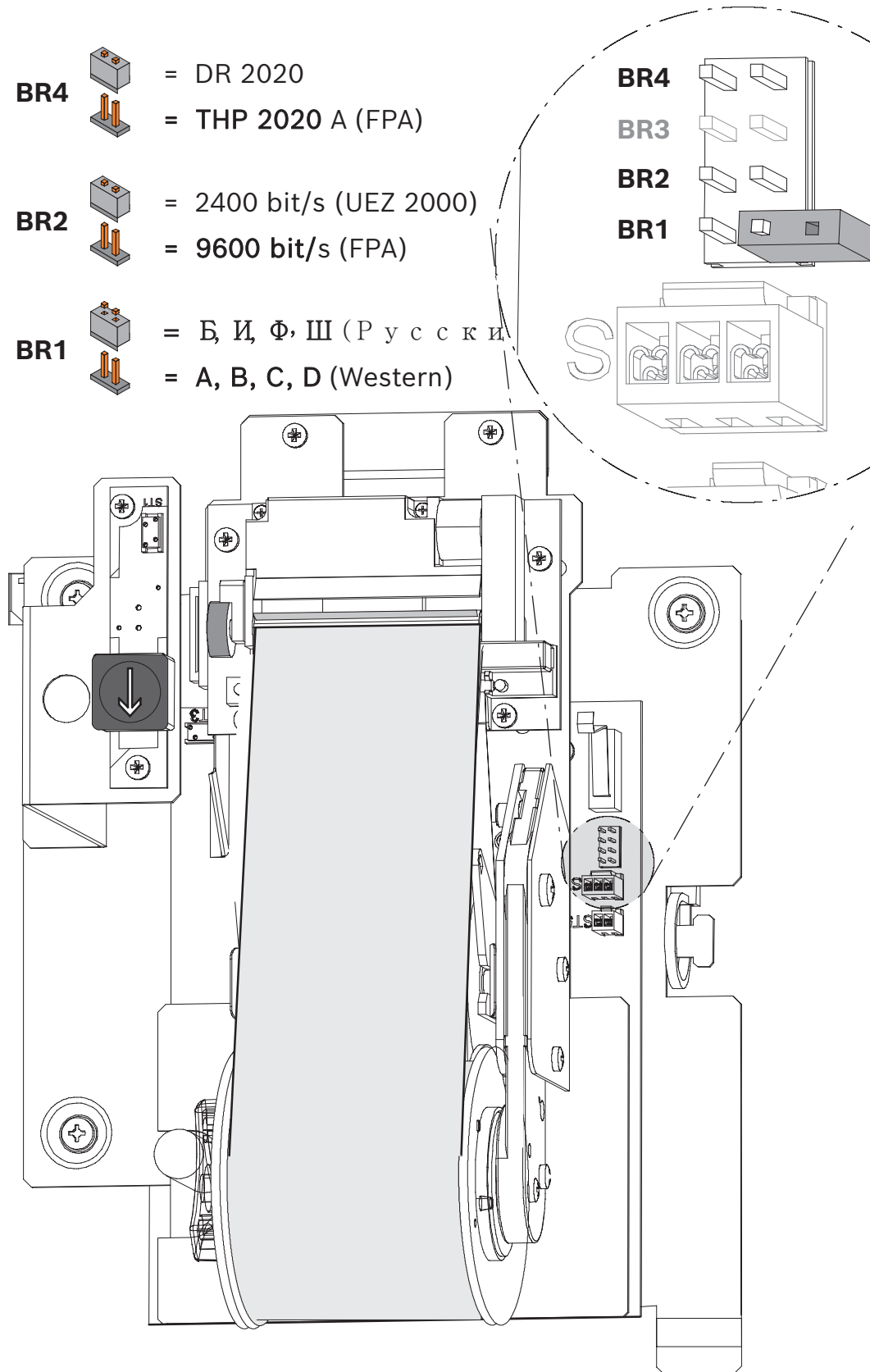

Figure 4.77: THP 2020 A jumpers

Changing the Paper Roll

The paper roll in the printer is changed as follows (see also *Changing the Paper Roll*, page 125):

1. Open the locks and remove the housing front panel.
2. Push down the paper locking lever.
3. Pull out the paper roll unit.
4. Tear off the paper before the last printed message, then hold the paper roll on the collecting spool and remove the securing disk by pulling it to the left. Remove the printed paper roll from the collecting spool.
5. Lift out the empty paper roll, making sure that the support pin does not fall out.
6. Remove the empty paper roll and slide a new paper roll onto the support pin.
7. Push the support pin with the new paper roll back between the metal clips.
8. Guide the paper behind the metal pin A and up behind the paper pressure roller B.
9. Pull out the paper up to the paper roll unit and secure the paper with at least one of the pins of the securing disk. Always slide the securing pins accurately along the guide slots of the collecting spool.
10. Let the collecting spool fall back into its original position and lift up the paper locking lever (see arrow).
11. Close the housing front panel and secure with the safety screws.
12. If necessary, tension the paper by pressing the paper feed button.



Notice!

Only use the thermal printer paper specified by the manufacturer (Bosch product ID 4.998.110.290, pack of 5 rolls).

The paper roll can be changed without turning off the printer.

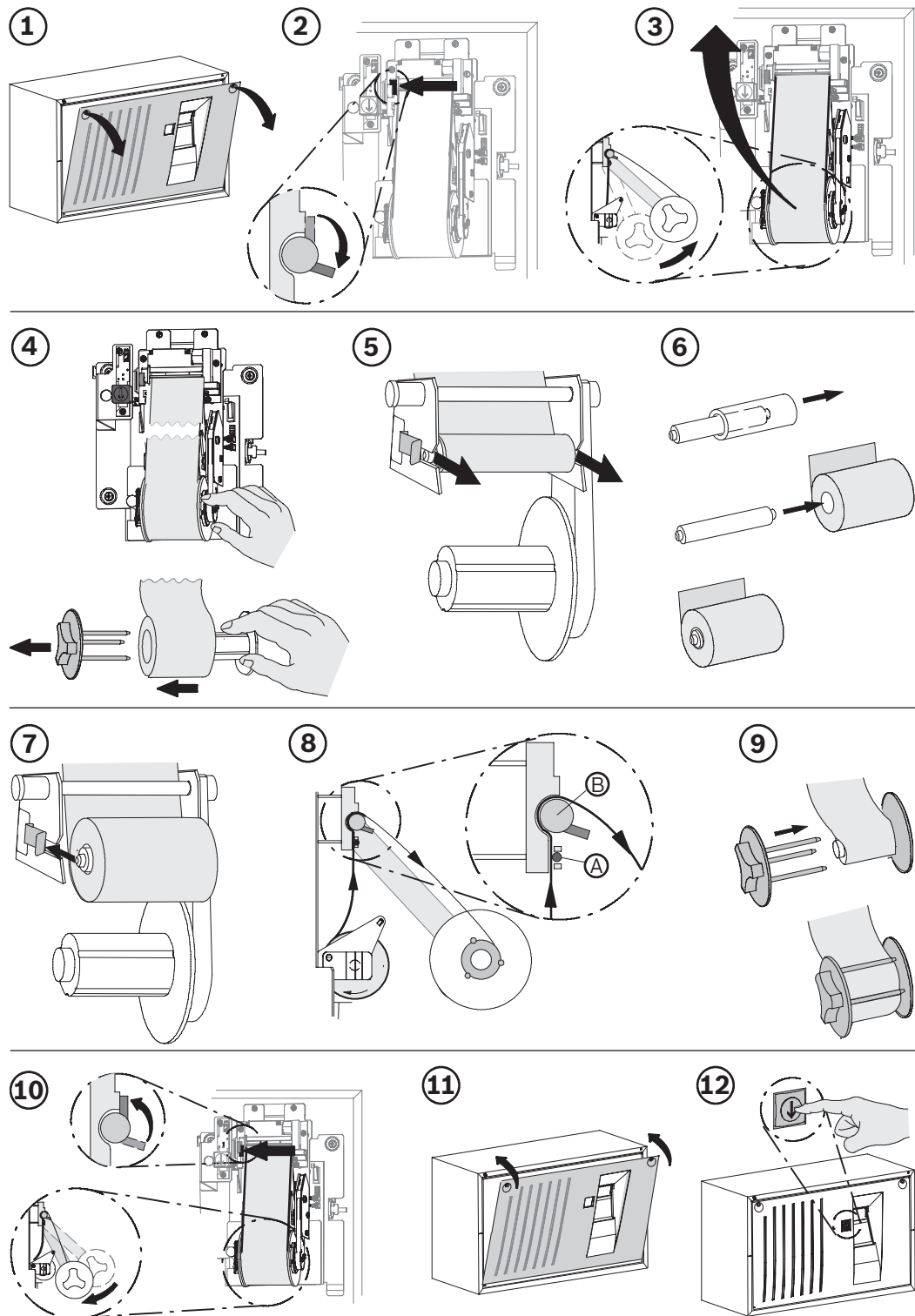

Figure 4.78: THP 2020 A - Changing the paper roll

4.14

Remote Keypad



Notice!

Installation must only be carried out by authorized specialist personnel.

Please refer to the figure for the scope of delivery.
 The technical data can be found in *Remote Keypad*, page 149.

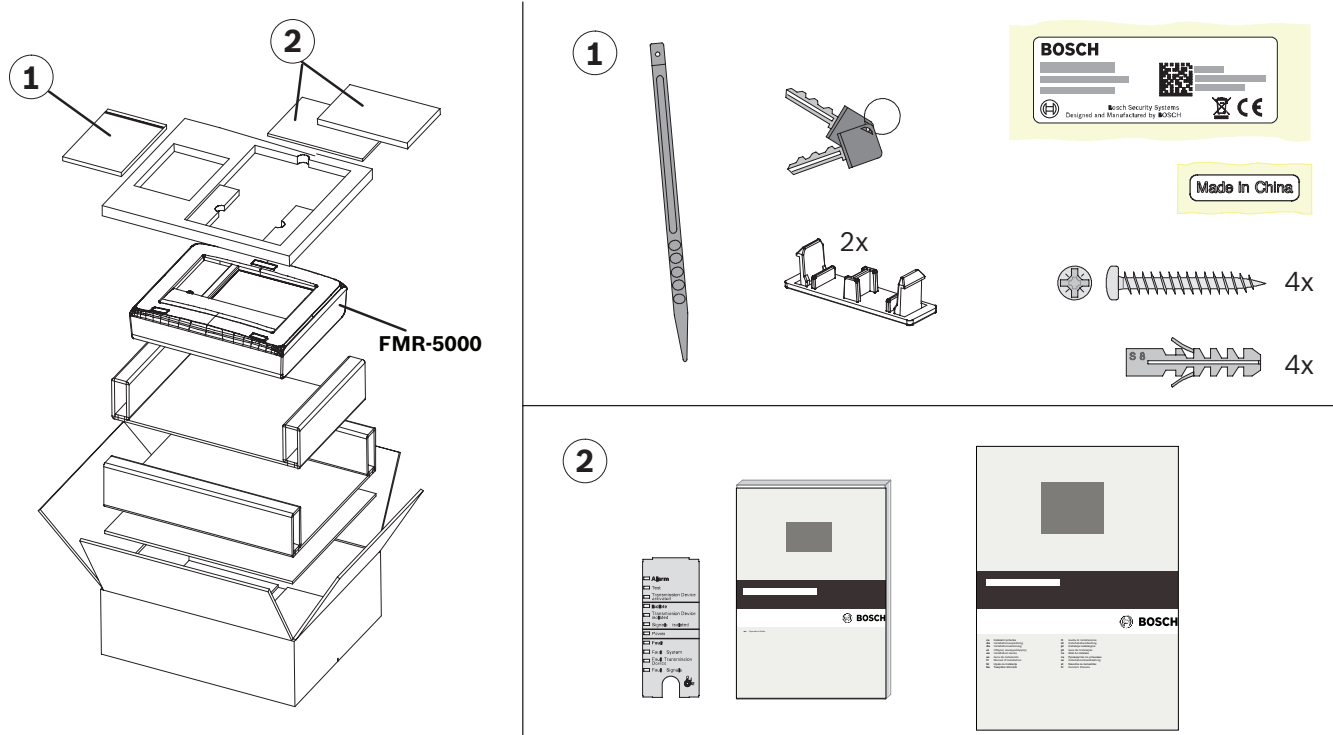

Figure 4.79: Remote Keypad - Scope of delivery

Functions

The remote keypad can be used to perform the same operating procedures as the (MPC) panel itself, enabling a networked system to be operated decentrally. It has the following functional elements:

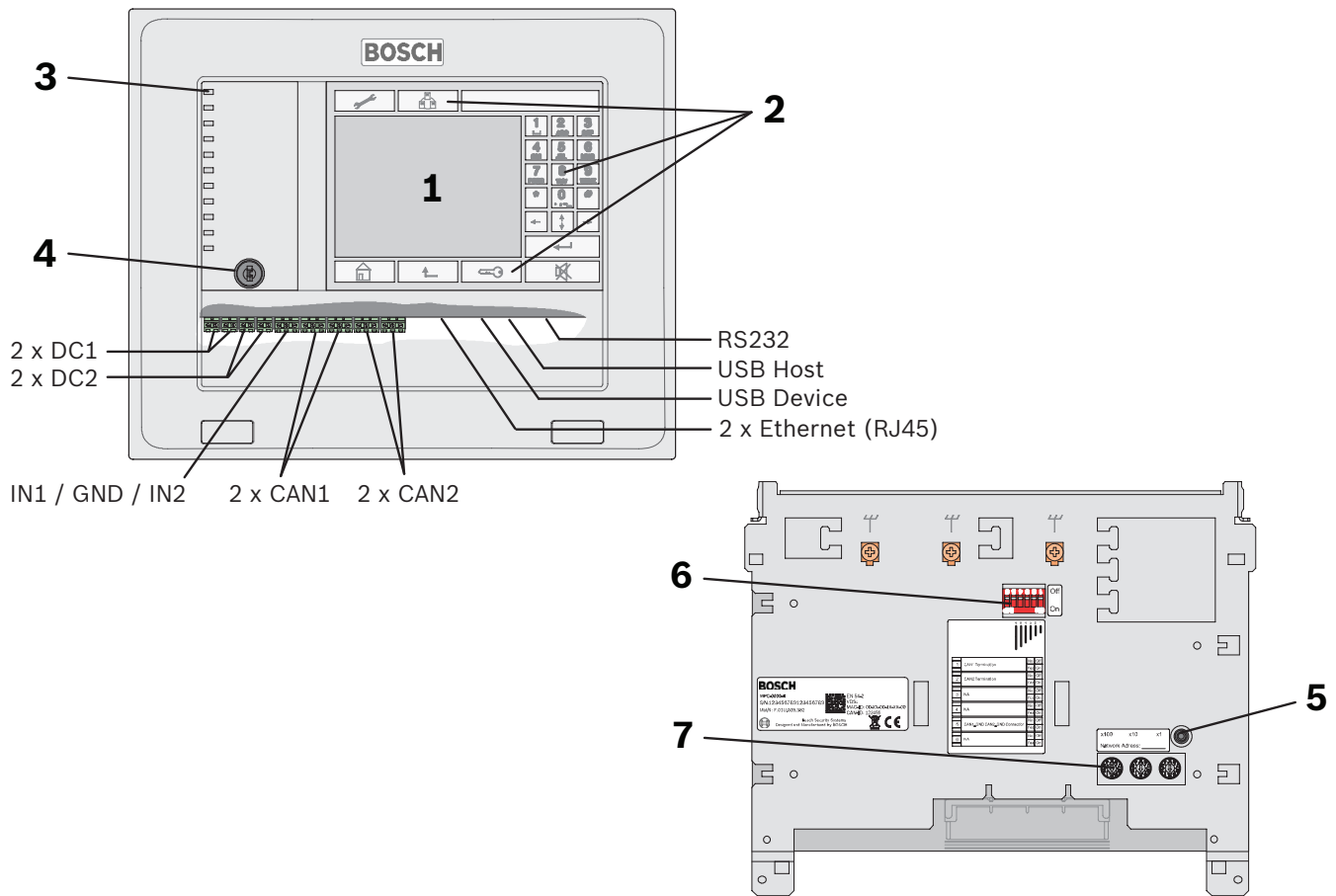

Figure 4.80: Remote Keypad - Functional elements

Pos.	Designation	Function
1	Touch screen	Operation of the networked system using virtual keys and variable display windows
2	Keypad	Standard inputs
3	12 LEDs	Display operating status
4	Key switch	Two switch positions, freely programmable, e.g. for switching between day/night mode or activating/deactivating local alarms
5	Reboot button	Remote keypad hardware reset
6	6-pin DIP switch	Configuration setting
7	3 rotary switches	Address setting

Note the maximum cable length of 2 m for connection to the USB and RS232 interfaces (see figure).

Information about address setting and configuration in the network can be found in *Addressing and Configuration in the Network*, page 139.

Installation

Follow the instructions for the required installation version.

Installation version	Installation instructions
Surface wall mounting (see figure, I)	See steps 1 to 13 and , page 133

Installation version	Installation instructions
Flush wall mounting (see figure, II)	See steps 1 to 13 and , page 134
Tilted installation (see figure, III)	See steps 1 to 13 and , page 135



Notice!

Dismantle the operating unit before housing installation. This avoids damage to the touch screen and makes it easier to screw in the lower fixing screws.

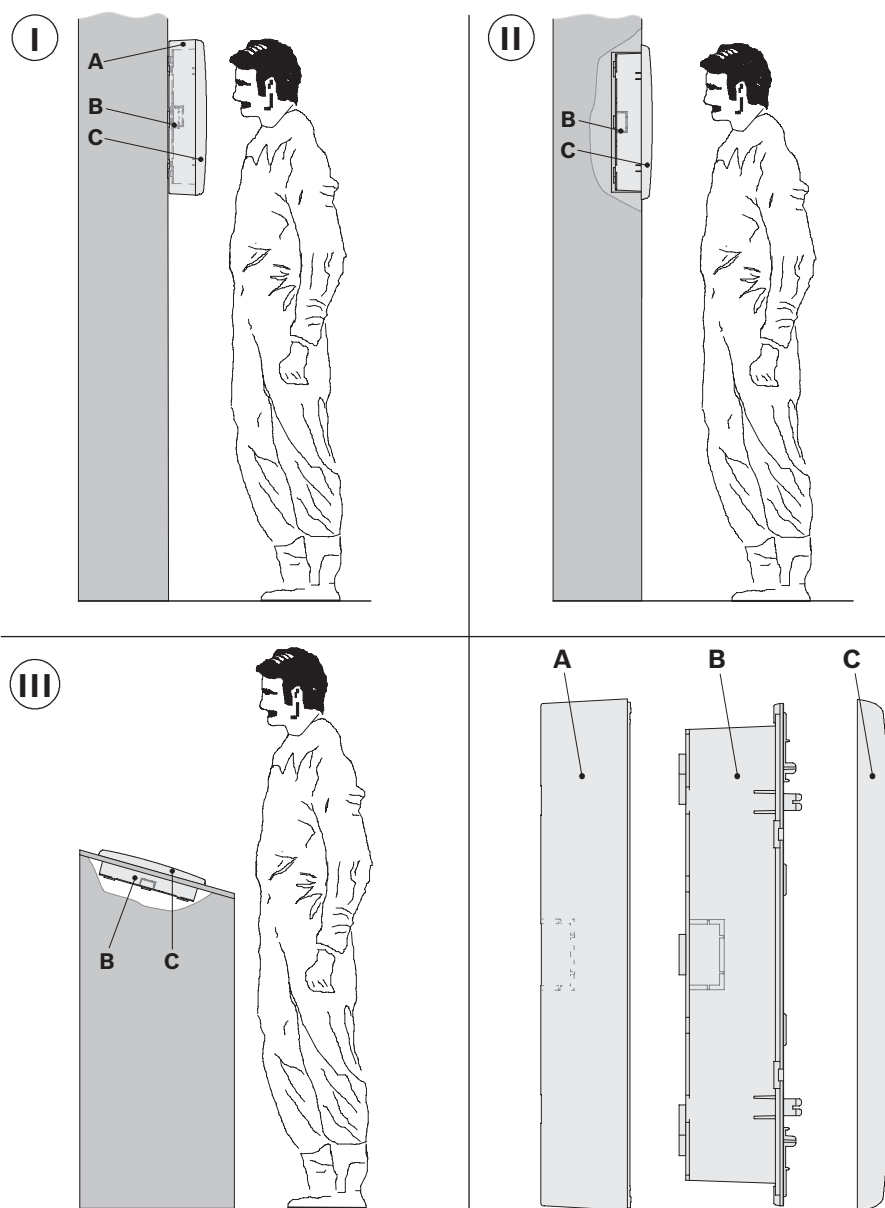

Figure 4.81: Remote Keypad installation variations

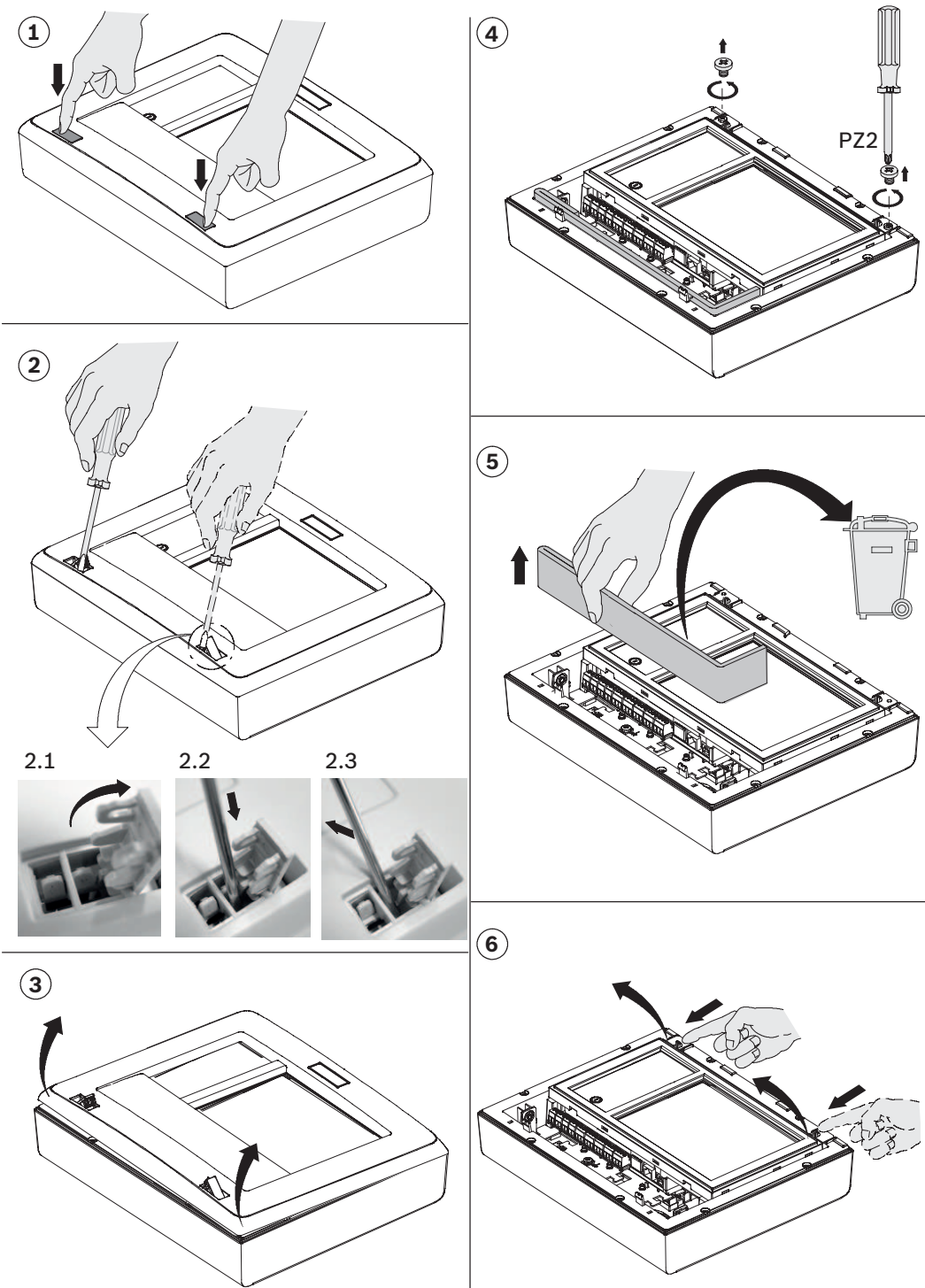

Figure 4.82: Remote Keypad installation (1-6)

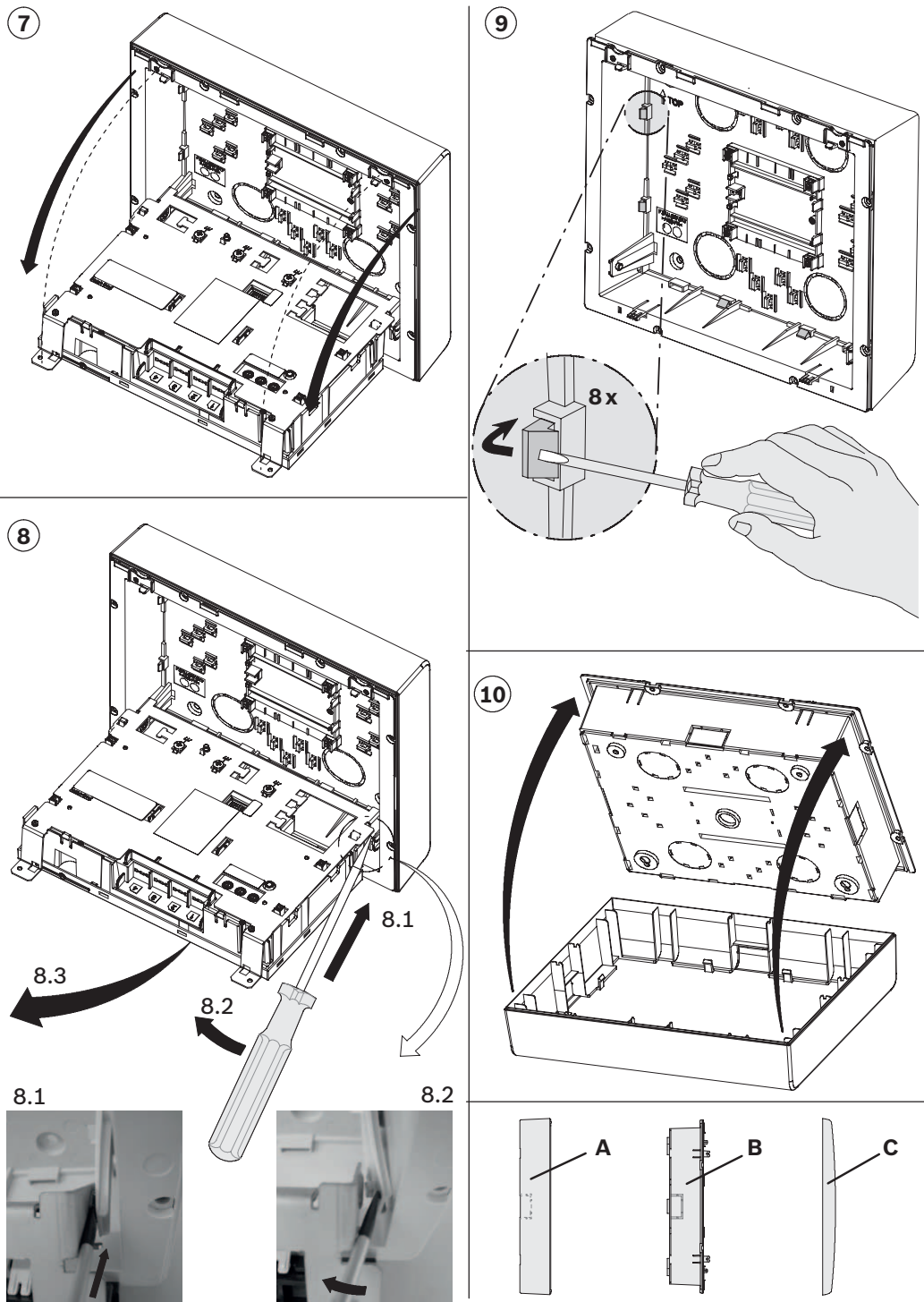
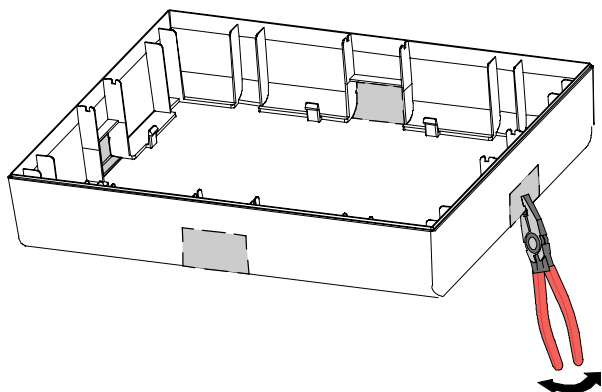
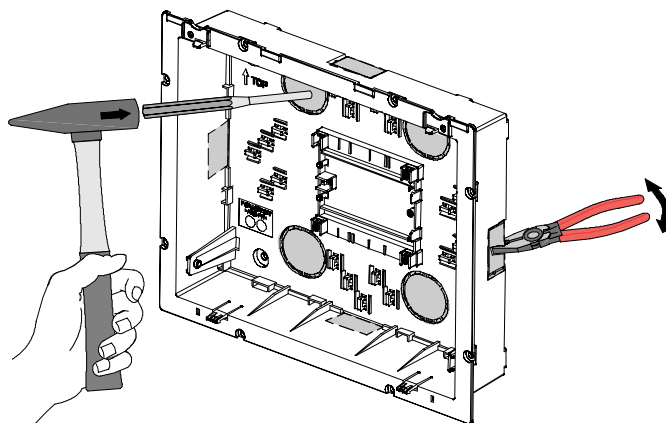

Figure 4.83: Remote Keypad installation (7-10)

11



12



13

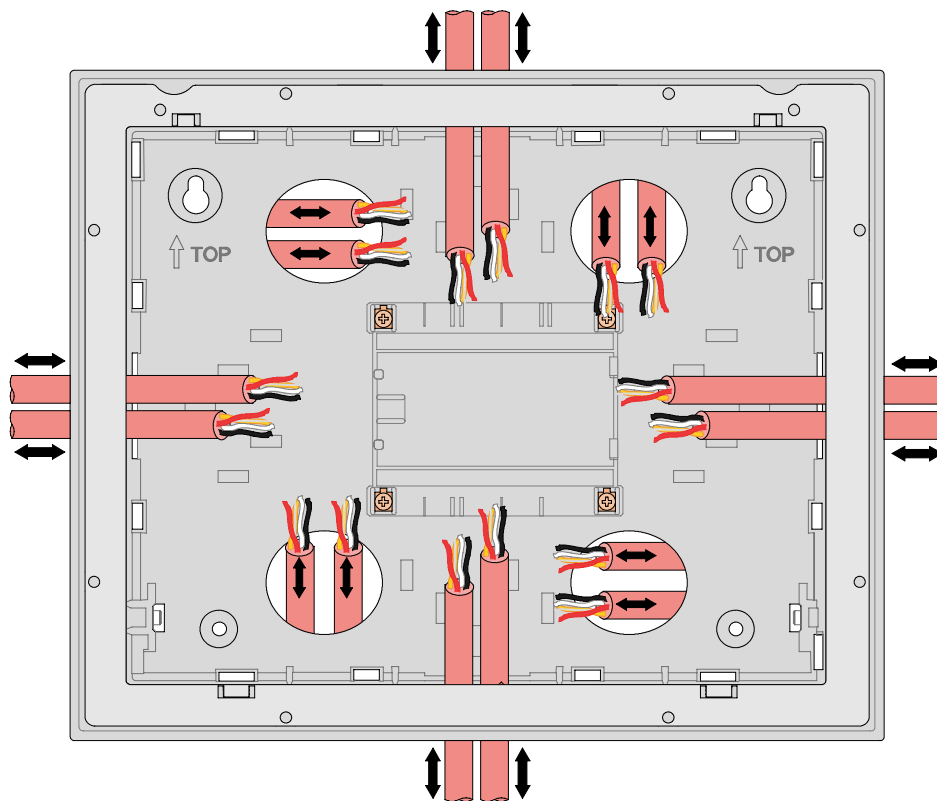

Figure 4.84: Remote Keypad installation (11-13)

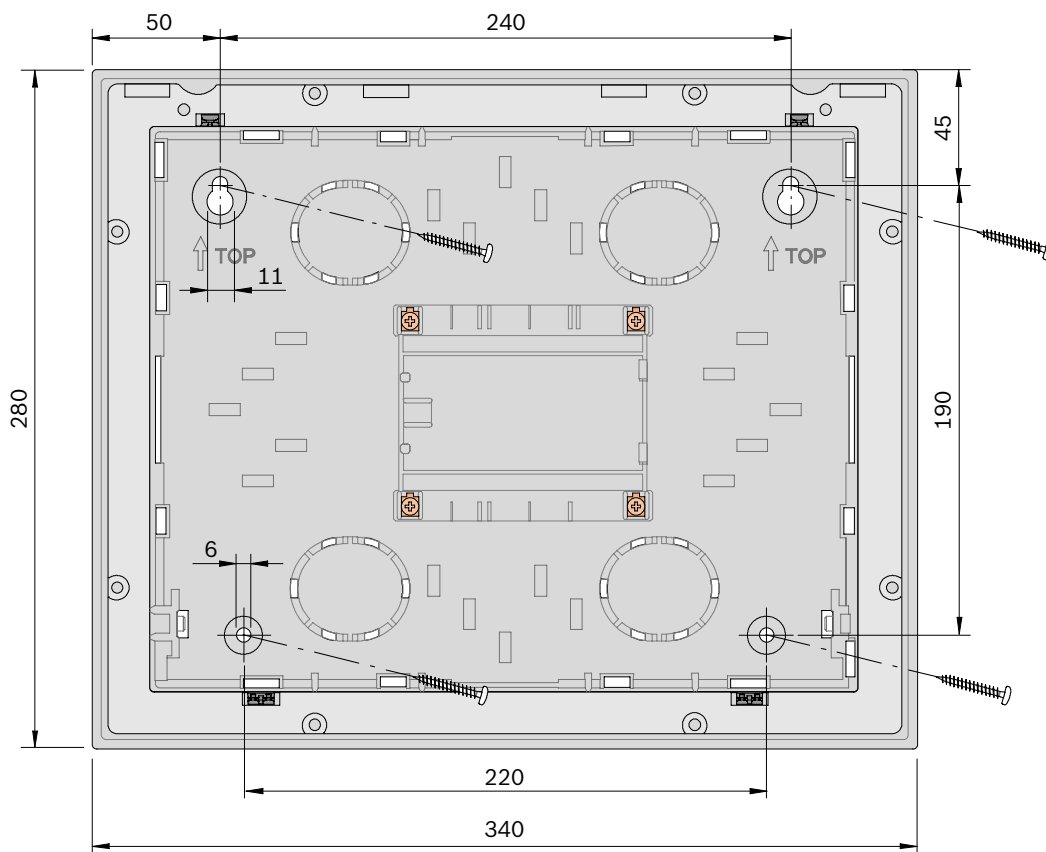
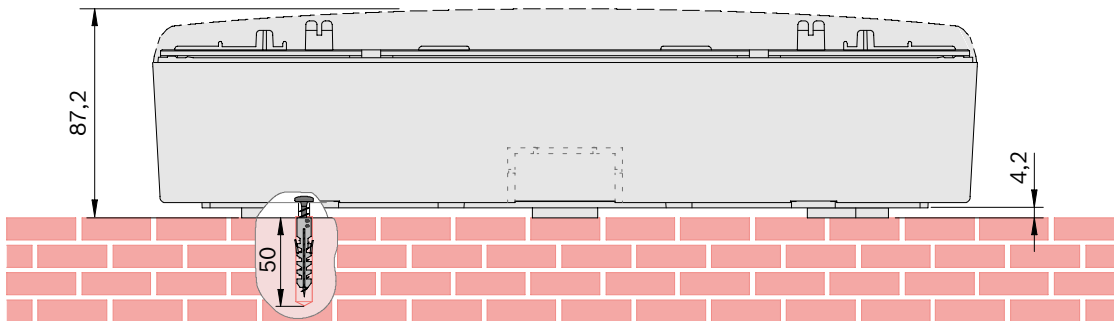
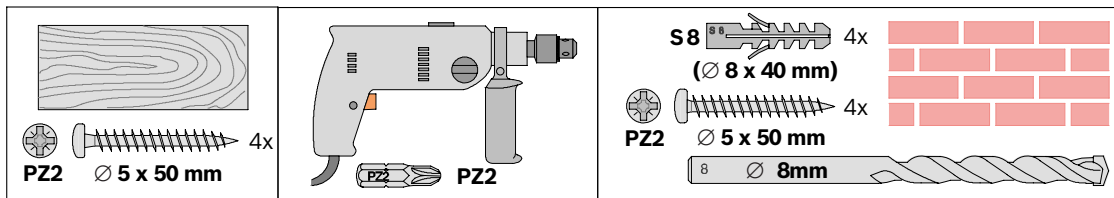

Figure 4.85: Remote Keypad surface mounting; dimensions in mm

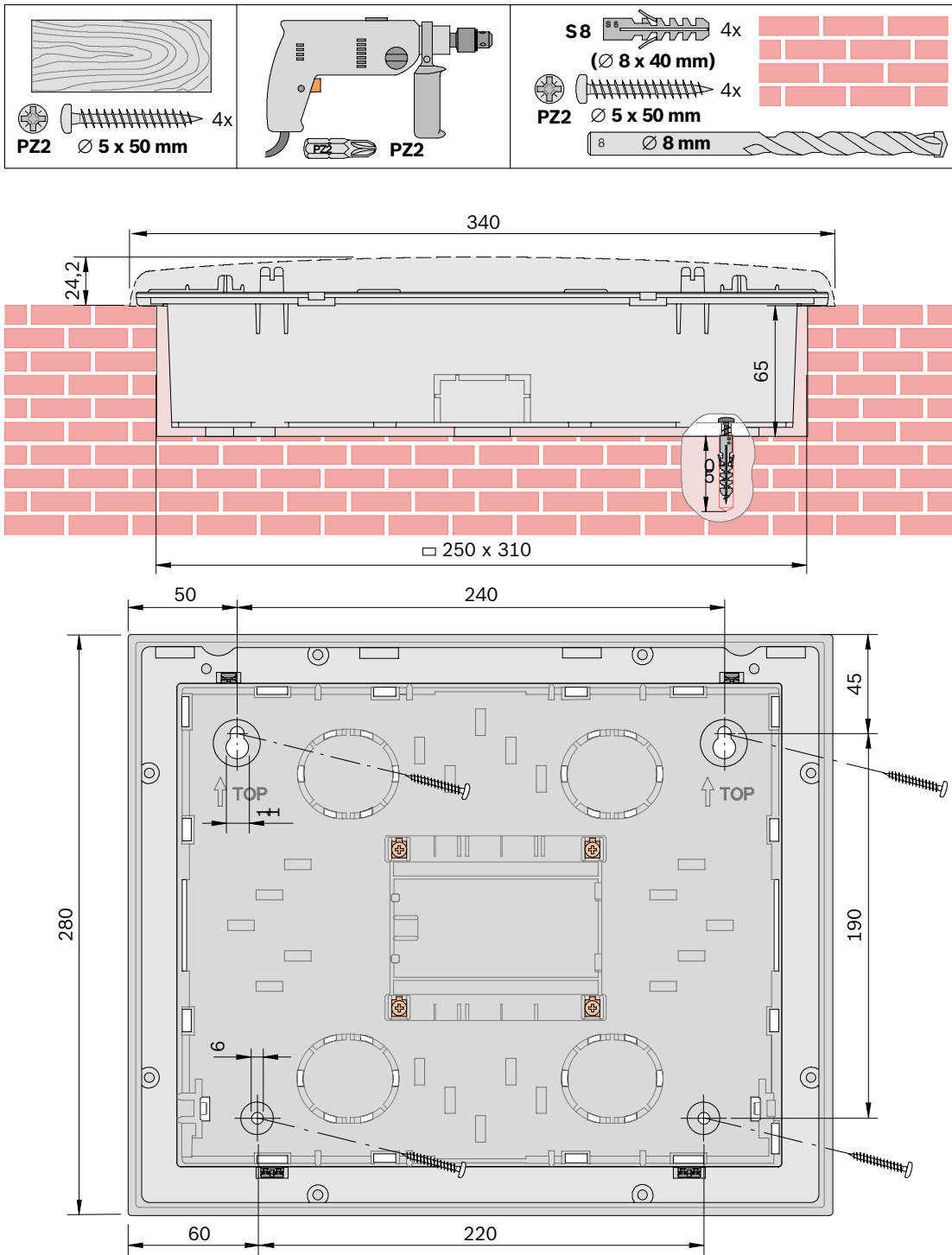

Figure 4.86: Remote Keypad flush mounting; dimensions in mm

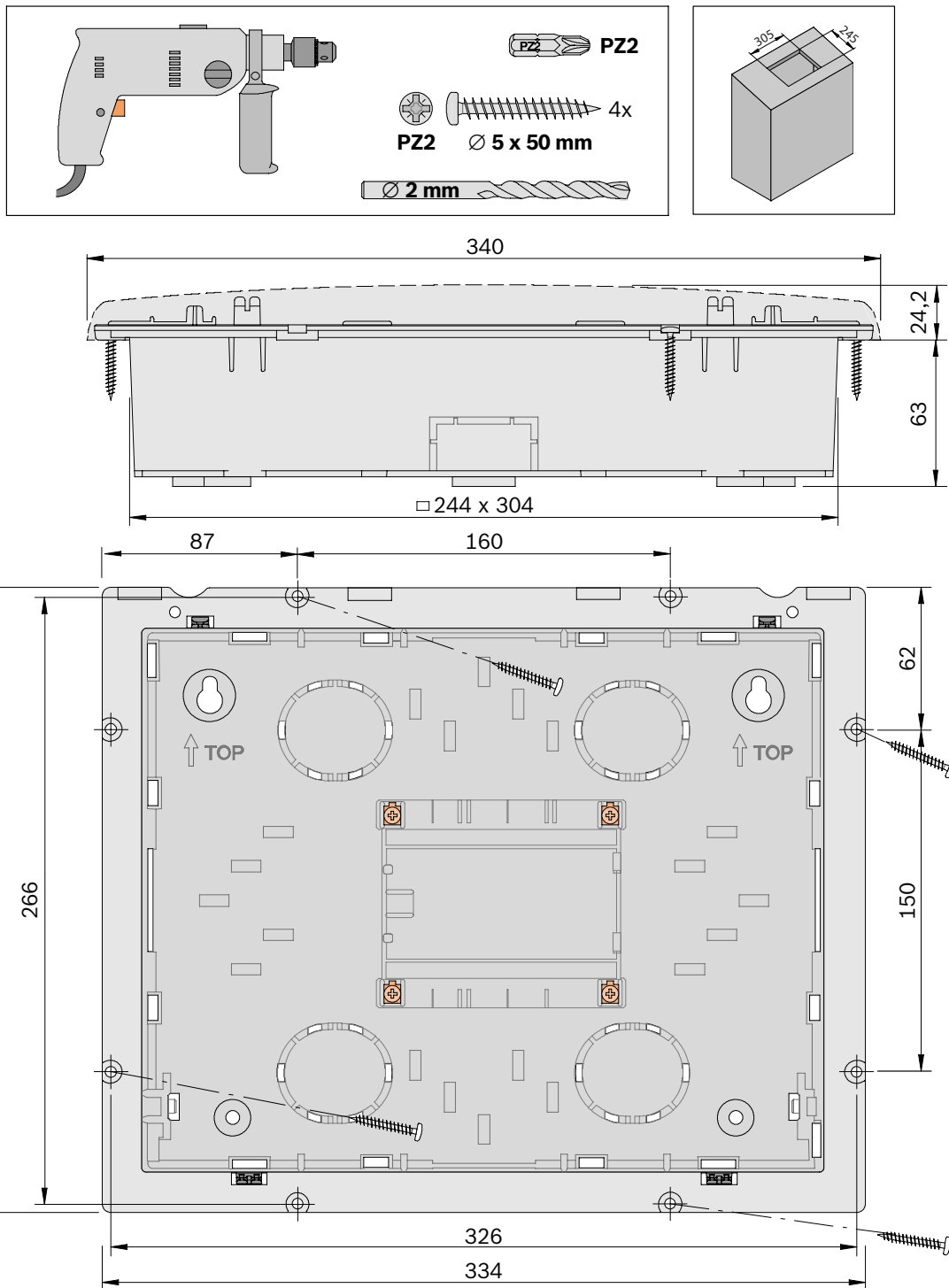

Figure 4.87: Remote Keypad tilting installation; dimensions in mm

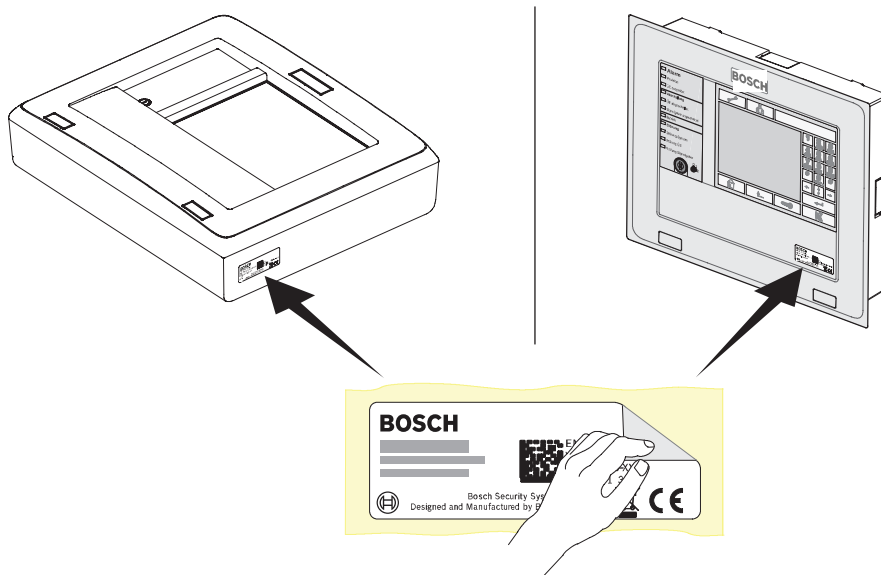

Figure 4.88: Remote Keypad sticker

Wiring

1. Place the shield wire on the support point (step 1)
2. Secure the cable with cable ties (step 1 to 4).

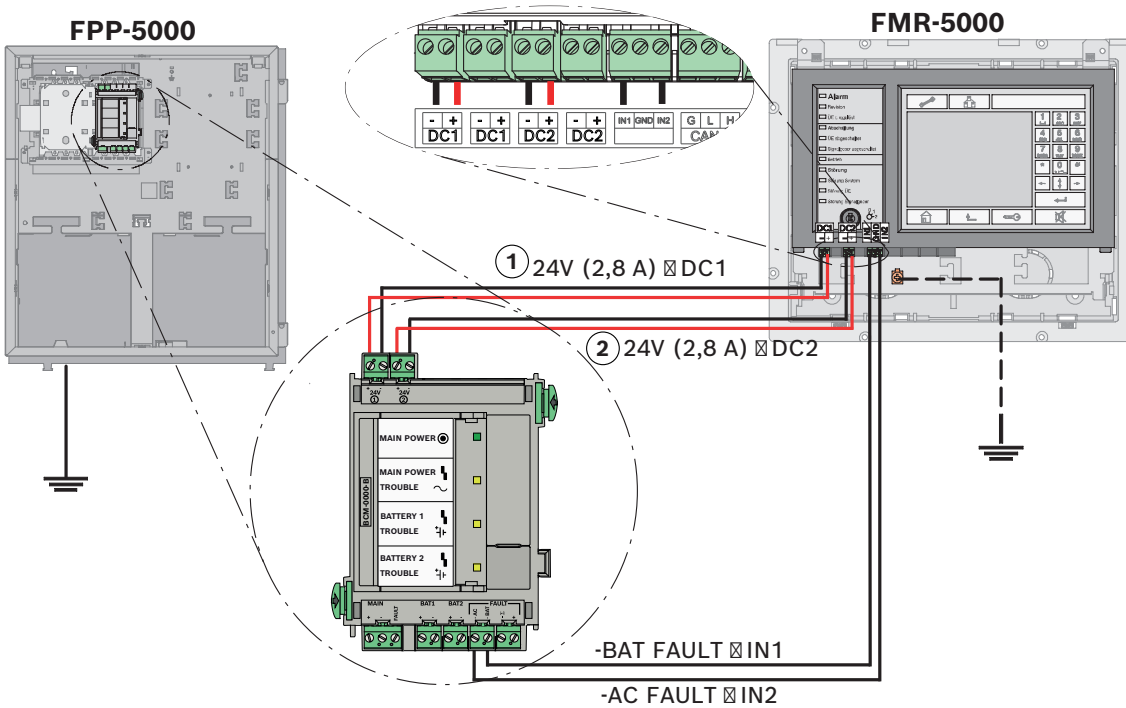
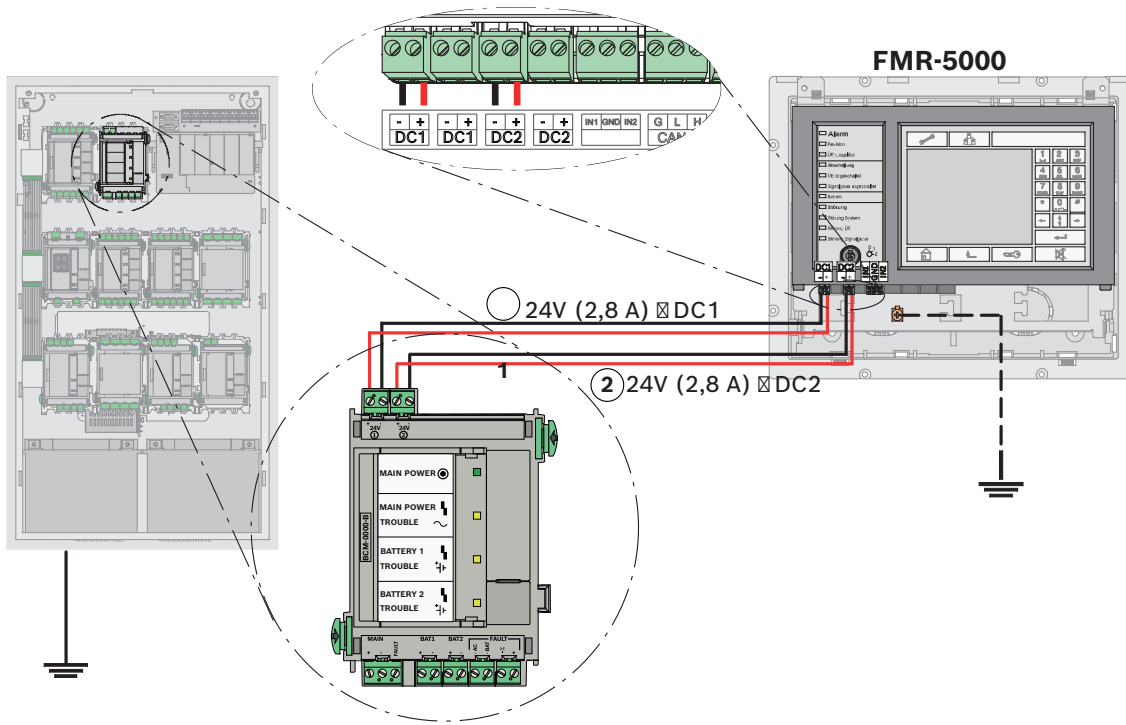

Figure 4.90: Remote Keypad wiring with BCM-0000-B



Notice!

The value 2.8 A must be set in the configuration window of the BCM-0000-B in the panel's programming software.

Addressing and Configuration in the Network

The remote keypads are identified in the network by a unique address. This address is set on the rotary switches and is known as the rotary switch number (RSN) (see the figures in the circle on the circuit diagrams).

Note the address on the sign above the rotary switches (see *Addressing and Configuration of Remote Keypad*, page 140, step 2).

Configure the remote keypad using the DIP switches. Mark the selected setting on the sign below the DIP switches (see *Addressing and Configuration of Remote Keypad*, page 140, step 4).

Addressing and Configuration of Remote Keypad

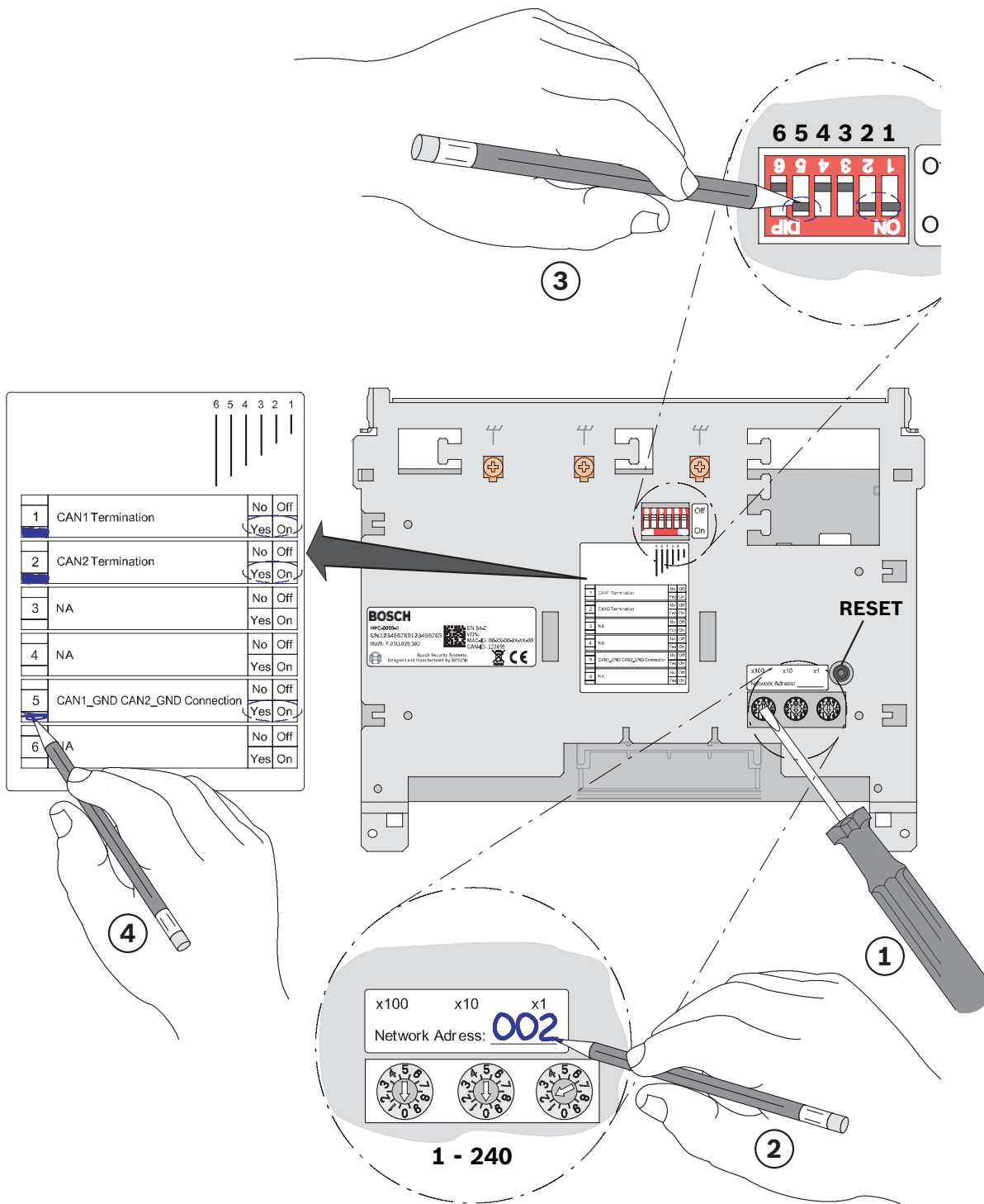

Figure 4.91: Addressing and Configuration

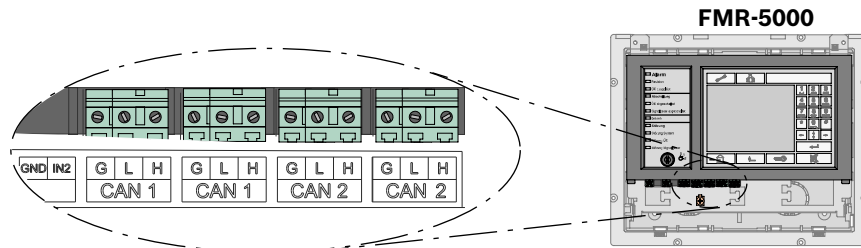

Figure 4.92: Network Connections

5 Commissioning

5.1 Notes

- Commissioning and the functional test may only be carried out by authorized specialist personnel.
- Observe all country-specific testing and acceptance regulations.
- A functional test must be carried out before commissioning.
Bosch recommends at least one functional test and one visual inspection per year.

Refer to

- *Functional Test, page 141*

5.2 Documentation

The panel controller is supplied with a DVD on which you will find the product documentation (installation instructions, system description).

The current and full product documentation can also be found on the Internet at www.boschsecurity.com

The fire panel is configured on a PC using the FSP-5000-RPS programming software. The programming software and the associated documentation can also be found on the DVD supplied with the panel. More recent versions of the software are available on the Internet for those with access rights.

Information about the programming software is also included in the online help.

5.3 Quick Guide for Commissioning

1. Connect the panel to the power supply.
2. Connect the panel controller to the PC (via USB). Make sure that the current version of the FSP-5000-RPS programming software is installed on your PC.
3. Start the auto-configuration. Edit the configuration according to the requirements of the fire detection system.
4. Load the configuration to the panel controller.
5. Start the walktest.
6. Test the power supply (see *Testing the Power Supply, page 142*)
7. Check the conventional and LSN functions (see *Testing the Conventional and LSN Functions, page 142*).
8. Test all detection points and activations as programmed (see *Testing the Addressing/Activation, page 143*).
9. Read out the diagnosis file and save the file as a test log.

5.4 Functional Test

5.4.1 Preparation

All components of the fire alarm system are installed and wired.

1. Turn on the fire panel.
2. Connect the laptop on which the FSP-5000-RPS programming software is installed to the fire panel.
3. Load the configuration.

Now go further with:

- Testing the power supply
- Testing the conventional and LSN functions
- Testing the addressing/activation

Refer to

- *Testing the Power Supply, page 142*
- *Testing the Addressing/Activation, page 143*

5.4.2

Testing the Power Supply

1. Measure the voltage of the batteries.
The target values are 12.0 V to 14.1 V, or 24 V to 28.2 V.
2. Test the power failure function
Remove the fuse and make sure that the failure of the power supply is indicated on the display.
Make sure that the time limit for failure of the power supply is set to around 25min (in the configuration).
3. Restore the power supply.
Once the fire alarm system is reconnected to the power supply, it automatically goes into standby mode, and the power supply failure display disappears.
4. Test the battery failure function:
Remove the cables between the batteries and the BCM-0000-B module.
Make sure that the time limit for failure of the batteries is set to around 25min (in the configuration).
Indication of battery failure can be delayed by up to 15min.
5. Reconnect the cables between the batteries and the BCM-0000-B module.
Once the connection with the batteries has been restored, the battery failure display must be reset manually.

5.4.3

Testing the Conventional and LSN Functions

1. Testing a conventional/LSN loop:
Disconnect the conventional/LSN loop by detaching the cable connection to the corresponding functional module.
Failure of the conventional/LSN loop must be indicated on the display.
Restore the connection between the conventional/LSN loop and the corresponding functional module and reset the error message. Now test all automatic and manual detectors.
2. Testing a conventional/LSN stub:
Disconnect the conventional/LSN stub by detaching the cable connection to the corresponding functional module.
Failure of the conventional/LSN stub must be indicated on the display.
Restore the connection between the conventional/LSN stub and the corresponding functional module and reset the error message. Now test all automatic and manual detectors.

5.4.4 Testing the Addressing/Activation

1. Test the activation of the transmission devices (TD/DACT/TSN/GSM/X25/X31) by triggering the corresponding assigned detector.
2. Test the activation of the transmission devices (TD/DACT/TSN/GSM/X25/X31) by initiating the corresponding fault.
3. Test the activation of extinguishing systems, door controls etc.
4. Test all internal alarm signaling equipment (e.g. audible and visual notification appliances).

6 Maintenance and Service

In Germany, maintenance work and inspection work on security systems are governed by the regulations of DIN VDE 0833. These regulations stipulate reference to the manufacturer's instructions for maintenance intervals.



Notice!

Have maintenance and inspection work carried out regularly by trained, qualified personnel. Bosch recommends a functional and visual inspection at least once a year.



Danger!

The fire panel and devices contain live components. Touching live components can result in electric shock. Disconnect the power supply before all maintenance or installation work.

6.1 Warranty

Defective devices are exchanged free of charge in the case of a claim under the warranty.

6.2 Repair

In the event of any defect, the entire device is exchanged.

6.3 Disposal



Unusable electrical and electronic devices must not be disposed of with normal household waste. They must be disposed of in compliance with the applicable regulations and directives (e.g. WEEE in Europe). See www.boschsecurity.com/xc/en/weee/ for further information.

6.4 Additional Documentation

The installation instructions and operating instructions supplied with the device are available as PDF files at www.boschsecurity.com. Additional documents (including the Wiring guide) are available to those with access rights at the extranet.



Notice!

The hexadecimal error codes can be found at the extranet (access rights required): LSN diagnostic data (F.01U.081.090).

**Notice!**

The description of security item types can be found on the Extranet (access right required): Security item types (F.01U.353.668).

7 Technical Data

7.1 System Limits

Panels/remote keypads/OPC server in the network	Max. number
Ethernet / CAN loop	32
CAN bus	8

LSN elements	Max. number
Stand-alone panel	4096
Per network panel	2048
Total network	32768

NAC groups	Max. number
NAC groups with more than one FNM-420, per loop	6

Praesideo, PAVIRO	Max. number
In CAN network, per panel	1
In total Ethernet network	1
Triggers (each trigger counts as one sounder group)	244

Per fire panel	Max. number
Sets, e.g. bypass group	192
Functional modules	46
Printer	4
Alarm counters (external, internal, testing)	3
Entries in the event database	10000
FSP-5000-RPS configuration interfaces (USB, COM)	2
Maximum number of outputs (sounders, controls, etc.) activated in parallel due to the same event	508

Configuration limits per fire panel (FSP-5000-RPS)	Max. number
Timer channels	20
Time control programs	19
Configuration for a Specific Day	365
Permission levels	4
User profiles	200

Configuration limits per fire panel (FSP-5000-RPS)	Max. number
Sum counters and counters (in total)	60000
Exportable objects including counters in the entire panel cluster (without pre-defined system counters)	2000
Importable objects including counters (without pre-defined system counters)	2000
Automatic connections to remote keypad	3
Blocks of State-Dependent Rules (depending on what kind of activations are possible)	8
Maximum number of rules within a block	254

Number of functional modules	Max. number
ANI 0016 A	32
BCM-0000-B	8
CZM 0004 A	32
ENO 0000 B	8
FPE-5000-UGM	4
IOP 0008 A	32
IOS 0020 A	4
IOS 0232 A	4
LSN 0300 A	32
LSN 1500 A	11
NZM 0002 A	8
RMH 0002 A	32
RML 0008 A	32

7.2 Power loss of components

Component	Power loss
ANI 0016 A	0.62 W (all LEDs lit)
BCM-0000-B	<ul style="list-style-type: none"> - 0.96 W (controller + green LED lit) - 1.44 W (per AUX with 1.06 A load)
CZM 0004 A	<ul style="list-style-type: none"> - 1.65 W (for a line with 100 mA load) - 3.36 W (for 4 lines with 100 mA load each)
ENO 0000 B	<ul style="list-style-type: none"> - 1.44 W (1 relay activated) - 7.80 W (4 relays activated + key deposit heating active)
FMR-5000-C	5.52 W
FPE-5000-UGM	0.17 W

Component	Power loss
IOP 0008 A	0.24 W
IOS 0020 A	0.36 W
IOS 0232 A	0.36 W
LSN 0300 A	- 1.50 W (AUX with 490 mA load) - 2.72 W (LSN)
LSN 1500 A	- 8.00 W (AUX) - 14.70 W (LSN with 750 mA load)
MPC-xxxx-C	5.40 W
NZM 0002 A	0.96 W
PRD 0004 A	0.07 W
PRS-0002-C	0.07 W
RMH 0002 A	1.16 W
RML 0008 A	1.04 W (all relays activated)
UPS 2416 A	28.00 W

7.3

Housing and Accessories

7.3.1

Housings for Frame Installation

Housing material	Sheet steel, painted
Housing color	Slate gray, RAL 7015; front: anthracite gray, RAL 7016

Housing type	Dimensions (H x W x D)	Dimensions including mounting frame	Weight
CPH 0006 A	approx. 638 x 440 x 145 mm	approx. 663 x 455.5 x 236 mm	12.5 kg
MPH 0010 A	approx. 638 x 440 x 145 mm	approx. 663 x 455.5 x 236 mm	12.5 kg
EPH 0012 A	approx. 638 x 440 x 145 mm	approx. 663 x 455.5 x 236 mm	13.2 kg
PMF 0004 A	approx. 502 x 440 x 145 mm	approx. 527 x 455.5 x 236 mm	11.4 kg
PSF 0002 A	approx. 267 x 440 x 145 mm	approx. 292 x 455.5 x 236 mm	6.4 kg
USF 0000 A	approx. 267 x 440 x 145 mm	approx. 292 x 455.5 x 236 mm	6.4 kg

7.3.2

Housings for Wall Mounting

Housing material	Sheet steel, painted
Housing color	Slate gray, RAL 7015; front: anthracite gray, RAL 7016

Housing type	Dimensions (H x W x D)	Weight
HCP 0006 A	approx. 638 x 440 x 149 mm	12.5 kg
HBC 0010 A	approx. 840 x 440 x 149 mm	17.0 kg
HBE 0012 A	approx. 840 x 440 x 149 mm	17.0 kg

Housing type	Dimensions (H x W x D)	Weight
PSB 0004 A	approx. 502 x 440 x 149 mm	11.4 kg
PSS 0002 A	approx. 267 x 440 x 149 mm	6.4 kg
DIB 0000 A	approx. 267 x 440 x 149 mm	6.4 kg

7.3.3 PRS-0002-C Panel Rail Short for 2 Modules

Input voltage	24 V DC (20 V DC to 30 V DC)
Current consumption at 24 V DC	2.8 mA
Maximum input current	8 A at 24 V DC
Permissible operating temperature	-5 °C to 50 °C (23 °F to 122 °F)
Permissible storage temperature	-20 °C to 60 °C (-4 °F to 140 °F)
Material	ABS plastic, Poly lac PA-766 (UL94 V-0)
Color	Satin finish, anthracite, RAL 7016

7.3.4 PRD 0004 A Panel Rail Long for 4 Modules

Input voltage	24 V DC (20 V DC to 30 V DC)
Current consumption at 24 V DC	2.8 mA
Maximum input current	8 A at 24 V DC
Permissible operating temperature	-5 °C to 50 °C
Permissible storage temperature	-20 °C to 60 °C
Material and color	ABS plastic (UL94 V-0), satin finish, anthracite, RAL 7016
Space required (H x W x D)	approx. 146 x 396 x 35 mm
Weight	approx. 280 g

7.3.5 FPO-5000-PSB1/FPO-5000-PSB-CH Power Supply Brackets

Permissible operating temperature	-5 °C to 50 °C
Permissible storage temperature	-20 °C to 60 °C
Weight	
– FPO-5000-PSB1	approx. 550 g
– FPO-5000-PSB-CH	approx. 395 g

Material	PA6 plastic, Grilon BS V0 (UL94 V-0)
Color	satin finish, anthracite, RAL 7016

7.3.6

UPS 2416 A Universal Power Supply 24 V/6 A

Input voltage range	100 V AC to 240 V AC
Input frequency	50 Hz to 60 Hz
Input current	max. 1.95 A
Efficiency	> 85 %
Back-up time	>16 ms at 115 V AC
Output voltage	26 V DC to 29 V DC
Maximum output current	6 A
Maximum power	160 W (permanent)
Cooling	Ventilation without ventilator
Safety standards	IEC 60950/EN 60950
Permissible operating temperature	-5 °C to 50 °C
Permissible storage temperature	-20 °C to 60 °C
Housing material and color	Aluminum, anodized, black satin finish
Space required (H x W x D)	approx. 200 x 100 x 40 mm
Weight	approx. 780 g

7.4

Panel Controller and Remote Keypad

7.4.1

MPC

Display element	TFT touch screen, 320 x 240 pixels, 127.5 mm x 170 mm active area
Operating elements	22 buttons, 1 key switch, 12 LEDs, 1 reboot button
Interfaces	CAN1, CAN2, ETH1, ETH2, USB, RS232
Signal inputs	IN1/IN2
Max. length of CAN cable for system networking	L_{\max} = 1000 m, depending on configuration, cable type and topology
Input voltage	20 V DC to 30 V DC
Maximum current consumption	<ul style="list-style-type: none"> - Standby mode: 136 mA at 24 V DC - In case of alarm: 226 mA at 24 V DC
Permissible operating temp.	-5 °C to 50 °C
Permissible storage temperature	-20 °C to 70 °C
Space required (H x W x D)	190 x 404 x 60 mm
Weight	Approx. 2 kg

7.4.2 Remote Keypad

Display element	TFT touch screen, 320 x 240 pixels, 127.5 mm x 170 mm active area
Operating and display elements	22 buttons, 1 key switch, 12 LEDs, 1 reboot button
Interfaces	CAN1, CAN2, ETH1, ETH2, USB, RS232
Signal inputs	IN1/IN2
Permissible length of CAN cable for system networking	$L_{\max} = 1000$ m, depending on configuration, cable type and topology
Recommended cable type for CAN connection	J-Y-ST/Y2 x 2 x 0.8
Power supply connections	DC1 (power supply), DC2 (redundant power supply)
Input voltage	12 V DC to 30 V DC, from FPA-5000 or FPP-5000
Maximum power supply line resistance	18 Ω
Maximum current consumption	<ul style="list-style-type: none"> - Standby mode: 141 mA at 24 V DC - In case of alarm: 231 mA at 24 V DC
Permissible operating temperature	-5 °C to 50 °C
Permissible storage temperature	-20 °C to 70 °C
Housing material and color	ABS plastic, light gray (similar to RAL 7035)
Space required (H x W x D)	280 x 340 x 87 mm
Weight	approx. 3 kg

7.4.3 FSP-5000-RPS Programming Software

The following minimum system requirements are defined for the FSP-5000-RPS Programming Software:

- Operating system: Windows 7 (32 bit or 64 bit), Windows 10 (32 bit or 64 bit).
- Hard disk: At least 1 GB storage capacity.
- RAM: At least 500 MB.

7.5 Functional Modules

The functional modules have the following technical specifications in common:

Permissible operating temperature	-5 °C to 50 °C
Permissible storage temperature	-20 °C to 60 °C
Relative humidity	Max. 95 % non-condensing
Housing material and color	ABS plastic, satin finish, anthracite, RAL 7016

Safety standards	EN 60950
Protection class	IP 30

Alternative technical data is listed for the individual modules.

7.5.1

ANI 0016 A Annunciator Module

Display elements	16 red LEDs, 16 yellow LEDs
Input voltage	20 V DC to 30 V DC
Maximum current consumption	
– Standby mode (all LEDs off)	6 mA
– In case of alarm (all LEDs on)	26 mA
Space required (H x W x D)	approx. 127 x 96 x 60 mm
Weight	approx. 206 g

7.5.2

BCM-0000-B Battery Controller Module

Input voltage	20.4 V to 30 V
Current consumption at 23 V DC	
– Standby operation	25 mA
– Fault	40 mA
Permissible battery capacities	
– with 2 batteries	24 to 26 Ah, 36 to 45 Ah
– with 4 batteries	48 to 52 Ah, 72 to 90 Ah
Maximum current	
– of the module	Max. 6 A
– to panel rails	Max. 6 A
– for switch outputs	Max. 5.6 A (2 x 2.8 A cannot be connected in parallel)
Maximum load of fault outputs BAT FAULT, AC FAULT and collective fault	0 V/0 - 20 mA
Maximum battery resistance (fault threshold)	430 mΩ
Voltage outputs	
– 2 switchable outputs	+24 V (20.4 - 30 V), 2.8 A, battery buffered (programmable)
Display and operating elements	
– 1 green LED	Mains power on
– 3 yellow LEDs	Mains fault /fault in battery 1/fault in battery 2

– 1 button	LED test, start charging manually, reset switch outputs
Space required (H x W x D)	approx. 127 x 96 x 60 mm
Weight	193 g
Permissible operating temperature	-5 °C to 50 °C
Permissible storage temperature	-25 °C to 85 °C

7.5.3

CZM 0004 A 4 Zone Conventional Module

Input voltage	20 V DC to 30 V DC
Maximum current consumption	
– Standby mode (all 4 zones)	65 mA (at 24 V DC)
– In case of alarm (all 4 zones)	65 mA + 100 mA per zone (at 24 V DC)
Outputs (OUT 1-OUT 4)	
– Maximum output voltage	20 V DC \pm 5%
– Maximum output current	100 mA \pm 10% per zone
– Max. line resistance	2 x 25 Ω per zone
Auxiliary power supply (AUX1-AUX4)	
– Max. output current (total of all 4 outputs)	230 mA
Space required (H x W x D)	approx. 127 x 96 x 60 mm
Weight without packaging	Approx. 135 g
Operating and display elements	8 LEDs (4 x red, alarm/4 x yellow, fault) 4 keys (LED test)

7.5.4

ENO 0000 B Fire Service Interface Module

Operating and display elements	2 LEDs (1 x red, 1 x yellow)/1 button (LED test)
Input voltage	20 V DC to 30 V DC
Current consumption	
– In standby	25 mA
– All relays tripped	60 mA
– Key deposit heating	additional 240 mA
Permissible relay contact load	1 A/30 V
Space required (H x W x D)	approx. 127 x 96 x 60 mm
Weight	approx. 150 g

7.5.5 FPE-5000-UGM Interface Module

Operating and display elements	4 two color LEDs (green = transmission / yellow = fault), 1 button (LED test)
Input voltage	20 V DC to 30 V DC
Maximum cable length	1000 m
Maximum line resistance	70 Ω
Transmission rate	9600 bit/s at 1000 m to 38400 bit/s at 200 m
Maximum current consumption	
– Standby operation	7 mA (at 24 V)
– One transmission path active	10 mA (at 24 V)
– Both transmission paths active	13 mA (at 24 V)
Space required (H x W x D)	approx. 110 x 90 x 60 mm
Weight	approx. 150 g

7.5.6 IOP 0008 A Input/Output Module

Input voltage	20 V DC to 30 V DC
Maximum current consumption	15 mA at 24 V DC
Maximum switch-on current	700 mA (short-circuit protected, $I_{max} = 1.5$ A)
Maximum cable length	3 m
Space required (H x W x D)	approx. 127 x 96 x 60 mm
Weight	approx. 150 g

7.5.7 IOS 0020 A 20 mA Communication Module

Input voltage	20 V DC to 30 V DC
Maximum current consumption	15 mA at 24 V DC
Maximum output current	1.3 A at 24 V DC resistive
Maximum cable lengths	– S1: 1000 m – S20: 1000 m – RS232: 3 m
Space required (H x W x D)	approx. 127 x 96 x 60 mm
Weight	approx. 175 g

7.5.8 IOS 0232 A RS232 Communication Module

Input voltage	20 V DC to 30 V DC
Maximum current consumption	15 mA at 24 V DC
Maximum cable length	3 m per interface

Space required (H x W x D)	approx. 127 x 96 x 60 mm
Weight	approx. 180 g

7.5.9

LSN 0300 A LSN improved Module 300 mA

Operating and display elements	2 LEDs (1 x red, alarm/ 1 x yellow, fault) 1 button (LED test)
Input voltage	20 V DC to 30 V DC
Output voltage	
– LSN standby voltage	30 ± 1.0 V DC
– LSN transmission voltage	30 ± 1.0 V DC + 1.6 ± 0.15 V DC (voltage range)
– Auxiliary supply AUX	28 ± 1.0 V DC
Maximum current consumption	1750 mA at 24 V DC
Nominal current consumption	
– Module	39 mA at 24 V DC
– LSN	1.7 x current consumption of the LSN elements
– AUX	1.2 x auxiliary supply AUX
Cable length	max. 1600 m, depending on configuration and cable type
Number of LSN elements	max. 127 LSN classic elements max. 254 LSN improved elements
LSN line current	max. 300 mA, depending on configuration and cable type
Auxiliary supply AUX (28 V DC)	max. 500 mA for an LSN loop (ERT technology) or 2 x max. 500 mA with 2 stubs
Space required (H x W x D)	approx. 127 x 96 x 60 mm
Weight	approx. 225 g

7.5.10

LSN 1500 A LSN improved Module 1500 mA

Operating and display elements	2 LEDs (1 x red, alarm/1 x yellow, fault) 1 button (LED test)
Input voltage	20 V DC to 30 V DC
Output voltage	
– LSN	30 ± 0.85 V DC
– Auxiliary supply AUX	28 ± 1.0 V DC
Maximum current consumption	4010 mA at 24 V DC
Nominal current consumption	
– Module	260 mA at 24 V DC

– LSN	1.7 x current consumption of the LSN elements
– AUX	1.2 x auxiliary supply AUX
Cable length	max. 3000 m, depending on configuration and cable type
Number of LSN elements	Max. 127 LSN classic elements Max. 254 LSN improved elements
LSN line current	
– Standby	max. 750 mA, depending on configuration and cable type
– Alarm	max. 1500 mA, depending on configuration and cable type max. 300 mA when connecting LSN classic elements
Auxiliary supply AUX (28 V DC)	max. 500 mA for an LSN loop (ERT technology) or 2 x max. 500 mA with 2 stubs
Space required (H x W x D)	approx. 127 x 190 x 60 mm
Weight	approx. 440 g

7.5.11

NZM 0002 A Notification Appliance Zone Module

Operating and display elements	4 LEDs (2 x red, alarm/2 x yellow, fault) 2 buttons (LED test)
Input voltage	20 V DC to 30 V DC
Maximum current consumption	
– Standby mode (both zones)	40 mA
– In case of alarms (both zones)	65 mA + 500 mA per notification appliance
Maximum output voltage	29.5 V DC
Maximum output current	
– For supply via panel rail	500 mA per notification appliance (in case of alarm)
– For external power supply	3 A per notification appliance (in case of alarm)
Space required (H x W x D)	approx. 127 x 96 x 60 mm
Weight	Approx. 135 g

7.5.12

RMH 0002 A Relay Module for mains voltage

Operating and display elements	4 LEDs (2 x red, alarm/2 x yellow, fault) 2 buttons (each on/off)
Fuses	F1 = T 6.3 A, F2 = T 6.3 A
Input voltage	20 V DC to 30 V DC
Feedback current	max. 8.5 mA per feedback output

Feedback voltage	max. 30 V DC
Maximum current consumption	
– Standby operation	10 mA
– Both relays tripped	50 mA
Maximum contact load	5 A at 120 V/230 V AC or 5 A at 30 V DC (resistive)
Maximum line resistance of feedback lines	2 x 25 Ω
Space required (H x W x D)	approx. 127 x 96 x 60 mm
Weight	Approx. 135 g

7.5.13 RML 0008 A Relay Module for Low Voltage

Input voltage	20 V DC to 30 V DC
Maximum current consumption	
– Standby operation	4 mA
– All relays tripped	68 mA
Maximum contact load	1 A at 30 V DC resistive
Space required (H x W x D)	approx. 127 x 96 x 60 mm
Weight	approx. 150 g

7.6 FPP-5000 External Power Supply Unit Kit 24 V/6 A

7.6.1 FPP-5000 Kit

Input voltage range	100 V AC to 240 V AC
Input frequency range	50 Hz to 60 Hz
Efficiency	> 85 %
Back-up time	>100 ms at 230 V AC
Output voltage	
– With mains supply	26 - 29 V DC (depending on temperature), 26.8 V DC nominal (at 40 °C)
– With battery supply	21 - 23 V DC
Maximum output current	6 A
Max. output	160 W (permanent)
Maximum load of fault outputs BAT FAULT, AC FAULT, and collective fault	0 V/0 - 20 mA
2 voltage outputs, switchable	+24 V/2.8 A (20.4 - 30 V), battery buffered
Housing material	Sheet steel, painted
Housing color	Slate gray, RAL 7015

	Front: anthracite gray, RAL 7016
Dimensions, installed (H x W x D)	approx. 527 x 456 x 326 mm
Protection class as per EN 60950	Class I equipment
Permissible operating temperature	-5 °C to 50 °C
Permissible storage temperature	-20 °C to 60 °C
Relative humidity	Max. 95 % non-condensing
Cooling	Ventilation without ventilator

7.6.2 FPP-5000-TI Trouble Interface

Input voltage	15 V DC to 30 V DC
Maximum current consumption	1.15 mA (at 24 V), from LSN
Protection class (IEC 60529)	IP 20
Addressing	using eight DIP switches
Space required (H x W x D)	approx. 127 x 96 x 60 mm

7.6.3 FPP-5000-TI13 Communication Interface

Input voltage	15 V DC to 33 V DC
Current consumption	
– From panel rail at 24 V DC	– 13.2 mA
– From LSN	– 3.25 mA
Protection class (IEC 60529)	IP 20
Space required (H x W x D)	approx. 127 x 96 x 60 mm

8 Appendix

8.1 Options with requirements under EN 54-2:1997/A1:2006

The panel provides the following options with requirements under EN 54-2:1997/A1:2006:

- Output for activation of fire alarm devices
- Activation of fire alarm transmission equipment
 - Output to fire alarm transmission equipment
 - Alarm acknowledgement input from fire alarm transmission equipment
- Output for activation of fire protection equipment
 - Output type A
 - Output type B
 - Output type C
 - Fault monitoring of fire protection equipment
- Transmission delay
- Dependency of fire detection status on more than one alarm signal
 - Type A dependency
 - Type B dependency
 - Type C dependency
- Alarm counter

- Fault signal status
 - Fault signals from detection points
 - Complete failure of power supply
 - Output to fault signaling transmission equipment
- Disabled status
 - Disabling of addressable points
- Test status
- Daymode status

8.2 Component Overview

8.2.1 Frame Installation Housings, Mounting Frames and Installation Kits

Panel Housings for Frame Installation

Designation	Product ID
CPH 0006 A Modular Panel Housing for 6 Modules, Frame Installation	4.998.137.290
MPH 0010 A Modular Panel Housing for 10 Modules, Frame Installation	4.998.137.291

Extension Housings for Frame Installation

Designation	Product ID
EPH 0012 A Modular Extension Housing for 12 Modules	4.998.137.292
PMF 0004 A Power Supply Big, Frame Installation	4.998.137.294
PSF 0002 A Power Supply Small, Frame Installation	4.998.137.293
USF 0000 A Universal Housing Small, Frame Installation	4.998.147.119

Mounting Frames

Designation	Product ID
FBH 0000 A Mounting Frame Large	4.998.137.296
FHS 0000 A Mounting Frame Large with Distributor Rail	4.998.139.490
FMH 0000 A Mounting Frame Medium	4.998.137.297
FSH 0000 A Mounting Frame Small	4.998.137.298

48 cm (19") Installation Kits for Frame Installation Housing

Designation	Product ID
FRB 0019 A Installation kit, large, 15 height units	4.998.139.498
FRM 0019 A Installation kit, medium, 12 height units	4.998.139.499
FRS 0019 A Installation kit, small, 6 height units	4.998.139.500

8.2.2 Wall Mounting Housings and Installation Kits

Panel Housings for Wall Mounting

Designation	Product ID
HBC 0010 A Modular Panel Housing for 10 Modules	4.998.137.286
HCP 0006 A Modular Panel Housing for 6 Modules	4.998.137.285

Extension Housings for Wall Mounting

Designation	Product ID
DIB 0000 A Distribution Box	4.998.139.497
HBE 0012 A Modular Extension Housing for 12 Modules	4.998.137.287
PSB 0004 A Power Supply	4.998.137.289
PSS 0002 A Power Supply Small, Frame Installation	4.998.137.288

48 cm (19") Installation Kit for Wall Mounting Housing

Designation	Product ID
FRK 0019 A Installation kit	F.01U.511.304

8.2.3**Accessories for Housing****Front Doors (Transparent Plastic)**

Designation	Product ID
FDT 0000 A Front Door Transparent, lock right side	4.998.147.120
FDT 0001 A Large Front Door Transparent, lock right side	4.998.153.238
FDT 0002 A Large Front Door Transparent, lock left side	4.998.153.239
FDT 0003 A Front Door Transparent, lock left side	F.01U.508.703

Mounting Plates/Installation Accessories

Designation	Product ID
FPO-5000-EB Earth Bar	F.01U.513.251
HMP 0003 A Mounting Plate for Mounting Frame	F.01U.511.305
RLE 0000 A Junction Board	4.998.153.241

Mounting Kits for Ethernet switch and media converter

Designation	Product ID
FPM-5000-KES Mounting Kit for Ethernet Switch	F.01U.266.844
FPM-5000-KMC Mounting Kit for Media Converter	F.01U.266.845

8.2.4**Panel Rails**

Designation	Product ID
PRD 0004 A Panel Rail Long, for up to 4 Modules	4.998.137.280
PRS-0002-C Panel Rail Short, for up to 2 Modules	F.01U.284.903

8.2.5**Power Supply Units, Power Supply Brackets, Batteries**

Designation	Product ID
FPP-5000 External Power Supply Unit Kit	F.01U.511.307
FPP-5000-TI Trouble Interface for FPP-5000	F.01U.073.324

Designation	Product ID
FPP-5000-TI13 LSN Communication interface for FPP-5000	F.01U.161.679
UPS 2416 A Universal Power Supply 24 V/6 A	F.01U.500.367
FPO-5000-PSB-CH Power Supply Bracket	F.01U.078.860
FPO-5000-PSB1 Power Supply Bracket	F.01U.078.858
Battery 12 V/28 Ah	2.799.502.177
Battery 12 V/45 Ah	2.799.380.000

8.2.6

Panel Controller/Remote Keypad

MPC Panel Controllers

Designation	Product ID
MPC-0000-C Panel Controller DE, Labeling and documentation in German	F.01U.275.048
MPC-1300-C Panel Controller EN, Labeling and documentation in English	F.01U.275.049
MPC-1400-C Panel Controller PT, Labeling and documentation in Portuguese	F.01U.275.050
MPC-1500-C Panel Controller CZ, Labeling and documentation in Czech	F.01U.275.051
MPC-1600-C Panel Controller HU, Labeling and documentation in Hungarian	F.01U.275.052
MPC-1700-C Panel Controller IT/DE, Labeling and documentation in Italian/German	F.01U.275.053
MPC-2000-C Panel Controller ES, Labeling and documentation in Spanish	F.01U.275.054
MPC-3000-C Panel Controller PL, Labeling and documentation in Polish	F.01U.275.055
MPC-5000-C Panel Controller FR/NL, Labeling and documentation in French/Dutch	F.01U.275.056
MPC-6000-C Panel Controller EL, Labeling and documentation in Greek	F.01U.275.057
MPC-7000-C Panel Controller RO/EN, Labeling and documentation in Romanian/English	F.01U.275.058
MPC-8000-C Panel Controller RU, Labeling and documentation in Russian	F.01U.275.059
MPC-9000-C Panel Controller TR, Labeling and documentation in Turkish	F.01U.275.060

Remote Keypads

Designation	Product ID
FMR-5000-C-00 Remote Keypad DE, Labeling and documentation in German	F.01U.275.061
FMR-5000-C-02 Remote Keypad ES, Labeling and documentation in Spanish	F.01U.275.062
FMR-5000-C-03 Remote Keypad PT Labeling and documentation in Portuguese	F.01U.275.063
FMR-5000-C-05 Remote Keypad FR/NL, Labeling and documentation in French/Dutch	F.01U.275.064
FMR-5000-C-06 Remote Keypad EL Labeling and documentation in Greek	F.01U.275.065
FMR-5000-C-07 Remote Keypad RO/EN Labeling and documentation in Romanian/English	F.01U.275.072
FMR-5000-C-08 Remote Keypad RU Labeling and documentation in Russian	F.01U.275.066
FMR-5000-C-09 Remote Keypad TR Labeling and documentation in Turkish	F.01U.275.067
FMR-5000-C-13 Remote Keypad EN Labeling and documentation in English	F.01U.275.068
FMR-5000-C-14 Remote Keypad PT Labeling and documentation in Portuguese	F.01U.275.069
FMR-5000-C-15 Remote Keypad CZ Labeling and documentation in Czech	F.01U.275.070
FMR-5000-C-16 Remote Keypad HU Labeling and documentation in Hungarian	F.01U.275.071
FMR-5000-C-17 Remote Keypad IT/DE Labeling and documentation in Italian/German	F.01U.275.073

FPE-8000-SPC | FPE-8000-PPC panel controllers

Designation	Product ID
FPE-8000-SPC panel controller, standard license	F.01U.327.090
FPE-8000-PPC panel controller, premium license	F.01U.352.441

FPE-8000-FMR Remote keypad

Designation	Product ID
FPE-8000-FMR Remote keypad	F.01U.327.092

8.2.7 Functional Modules

Modules

Designation	Product ID
ANI 0016 A Annunciator Module	4.998.137.262
BCM-0000-B Battery Controller Module	F.01U.081.384
CZM 0004 A 4 Zone Conventional Module	4.998.137.270
ENO 0000 B Fire Service Interface Module	F.01U.063.204
FPE-5000-UGM Interface Module	F.01U.028.289
IOP 0008 A Input/Output Module	4.998.137.269
IOS 0020 A 20 mA Communication Module	4.998.137.266
IOS 0232 A RS232 Communication Module	4.998.137.267
LSN 0300 A LSN improved Module 300 mA	4.998.137.277
LSN 1500 A LSN improved Module 1500 mA	4.998.137.278
NZM 0002 A Notification Appliance Zone Module	4.998.137.275
RMH 0002 A Relay Module (for mains voltage)	4.998.137.274
RML 0008 A Relay Module (for low voltage)	4.998.137.265

Accessories

Designation	Product ID
FDP 0001 A Dummy Cover Plate, for empty module slots	F.01U.500.374
PSK 0001 A Labeling Strips, Wide, for module buttons	F.01U.500.366
PSL 0001 A Labeling Strips, Small, for ANI 0016 A module	F.01U.500.363

8.2.8 Cable Sets

Designation	Product ID
CBB 0000 A Cable Set BCM/Battery	4.998.153.244
CPA 0000 A Cable Set AT 2000	4.998.153.247
CPB 0000 A Cable BCM/UPS	4.998.153.243
CPR 0001 A Printer Cable	F.01U.500.372
CRP 0000 A Redundant MPC cable set	4.998.153.242

8.2.9 Thermal Printer

Designation	Product ID
THP 2020 A Thermal Printer, in frame installation housing	4.998.137.295

8.2.10 ETH/FOC Adapters

Designation	Product ID
EL1141-10B-BH Media Converter RJ45-FOC MM	F.01U.265.641
EL1141-B0B-BH Media Converter RJ45-FOC SM	F.01U.265.643
BPA-ESWEX-RSR20 Ethernet-Switch RJ45 and FOC MM	F.01U.258.203
RSR20-0800S2S2T Ethernet-Switch RJ45 and RJ45-FOC SM	F.01U.267.019

8.3 Additional documentation

8.3.1 Frame installation housings, mounting frames and installation kits

Panel housings for frame installation

Designation	Installation manual ID
CPH 0006 A Modular Panel Housing for 6 Modules, Frame Installation	4998154002
MPH 0010 A Modular Panel Housing for 10 Modules, Frame Installation	4998154002

Extension housings for frame installation

Designation	Installation manual ID
EPH 0012 A Modular Extension Housing for 12 Modules	4998154002
PMF 0004 A Power Supply Big, Frame Installation	F01U003083
PSF 0002 A Power Supply Small, Frame Installation	F01U003083
USF 0000 A Universal Housing Small, Frame Installation	F01U003083

Mounting Frames

Designation	Installation manual ID
FBH 0000 A Mounting Frame Large	4998153998
FHS 0000 A Mounting Frame Large with Distributor Rail	4998154018
FMH 0000 A Mounting Frame Medium	4998153999
FSH 0000 A Mounting Frame Small	4998154000

48 cm (19") Installation Kits for Frame Installation Housing

Designation	Installation manual ID
FRB 0019 A Installation kit, large, 15 height units	4998154015_610
FRM 0019 A Installation kit, medium, 12 height units	4998154017_610
FRS 0019 A Installation kit, small, 6 height units	F01U003352_610

8.3.2 Wall mounting housings and installation kits

Panel Housings for Wall Mounting

Designation	Installation manual ID
HBC 0010 A Modular Panel Housing for 10 Modules	4998153994
HCP 0006 A Modular Panel Housing for 6 Modules	4998153994

Extension Housings for Wall Mounting

Designation	Installation manual ID
DIB 0000 A Distribution Box	F01U003105_610
HBE 0012 A Modular Extension Housing for 12 Modules	4998153994
PSB 0004 A Power Supply	4998154010
PSS 0002 A Power Supply Small, Frame Installation	4998154010

48 cm (19") Installation Kit for Wall Mounting Housing

Designation	Installation manual ID
FRK 0019 A Installation kit	F01U005045

8.3.3 Accessories for housing

Front Doors (Transparent Plastic)

Designation	Installation manual ID
FDT 0000 A Front Door Transparent, lock right side	F01U003101
FDT 0001 A Large Front Door Transparent, lock right side	F01U003100
FDT 0002 A Large Front Door Transparent, lock left side	F01U003104
FDT 0003 A Front Door Transparent, lock left side	F01U003102

Mounting Plates/Installation Accessories

Designation	Installation manual ID
FPO-5000-EB Earth Bar	F01U005061
HMP 0003 A Mounting Plate for Mounting Frame	F01U003791
RLE 0000 A Junction Board	F01U003090_610

Mounting Kits for Ethernet switch and media converter

Designation	Installation manual ID
FPM-5000-KES Mounting Kit for Ethernet Switch	F01U260523
FPM-5000-KMC Mounting Kit for Media Converter	F01U260524

8.3.4 Panel rails

Designation	Installation manual ID
PRD 0004 A Panel Rail Long, for up to 4 Modules	4998153989
PRS-0002-C Panel Rail Short, for up to 2 Modules	F01U284926

8.3.5 Power supply units

Designation	Installation manual ID
FPP-5000 External Power Supply Unit Kit	F01U005065
FPP-5000-TI Trouble Interface for FPP-5000	F01U081396
FPP-5000-TI13 LSN Communication interface for FPP-5000	F01U164562
UPS 2416 A Universal Power Supply 24 V/6 A	F01U003349
FPO-5000-PSB-CH Power Supply Bracket	F01U079870
FPO-5000-PSB1 Power Supply Bracket	F01U079868

8.3.6 Panel controller | Remote keypad

Installation manuals FMR-5000-C and MPC-xxxx-C

Designation	Installation manual ID
FMR-5000-C	F01U258926
MPC-xxxx-C	F01U258925

User manuals FMR-5000-C and MPC-xxxx-C

Designation	User manual ID	Language
FMR-5000-C, MPC-xxxx-C	F01U258927	German
FMR-5000-C, MPC-xxxx-C	F01U258928	Czech
FMR-5000-C, MPC-xxxx-C	F01U258929	English
FMR-5000-C, MPC-xxxx-C	F01U258930	Greek
FMR-5000-C, MPC-xxxx-C	F01U258931	Spanish
FMR-5000-C, MPC-xxxx-C	F01U258932	French
FMR-5000-C, MPC-xxxx-C	F01U258933	Hungarian
FMR-5000-C, MPC-xxxx-C	F01U258934	Italian
FMR-5000-C, MPC-xxxx-C	F01U258935	Dutch
FMR-5000-C, MPC-xxxx-C	F01U258936	Polish
FMR-5000-C, MPC-xxxx-C	F01U258937	Portuguese
FMR-5000-C, MPC-xxxx-C	F01U258938	Russian
FMR-5000-C, MPC-xxxx-C	F01U258939	Turkish

Designation	User manual ID	Language
FMR-5000-C, MPC-xxxx-C	F01U258940	Romanian
FMR-5000-C, MPC-xxxx-C	F01U258941	Bulgarian
FMR-5000-C, MPC-xxxx-C	F01U258942	Latvian

Wiring guide

Designation	Wiring guide ID
MPC-xxxx-C	F01U009201

Installation manuals FPE-8000-FMR and FPE-2000-SPC | FPE-2000-PPC | FPE-8000-SPC | FPE-8000-PPC

Designation	Installation manual ID
FPE-8000-FMR	F01U347558
FPE-2000-SPC panel controller, standard license	F01U347557
FPE-2000-PPC panel controller, premium license	F01U347557
FPE-8000-SPC panel controller, standard license	F01U347557
FPE-8000-PPC panel controller, premium license	F01U347557

User manuals FPE-8000-FMR and FPE-2000-SPC | FPE-2000-PPC | FPE-8000-SPC | FPE-8000-PPC

Designation	User manual ID
FPE-2000-SPC panel controller, standard license	F01U378877
FPE-2000-PPC panel controller, premium license	F01U378877
FPE-8000-SPC panel controller, standard license	F01U378877
FPE-8000-PPC panel controller, premium license	F01U378877
FPE-8000-FMR	F01U378877

8.3.7

Functional modules

Modules

Designation	Installation manual ID
ANI 0016 A Annunciator Module	4998153972_610
BCM-0000-B Battery Controller Module	F01U081382
CZM 0004 A 4 Zone Conventional Module	4998153977
ENO 0000 B Fire Service Interface Module	F01U063946
FPE-5000-UGM Interface Module	F01U028306
IOP 0008 A Input/Output Module	4998153976
IOS 0020 A 20 mA Communication Module	4998153974

Designation	Installation manual ID
IOS 0232 A RS232 Communication Module	4998153975
LSN 0300 A LSN improved Module 300 mA	4998153984
LSN 1500 A LSN improved Module 1500 mA	4998153983
NZM 0002 A Notification Appliance Zone Module	4998153982
RMH 0002 A Relay Module (for mains voltage)	4998153981
RML 0008 A Relay Module (for low voltage)	4998153973

Accessories

Designation	Installation manual ID
FDP 0001 A Dummy Cover Plate, for empty module slots	F01U003084

8.3.8**Cable sets**

Designation	Installation manual ID
CBB 0000 A Cable Set BCM/Battery	F01U003099
CPB 0000 A Cable BCM/UPS	F01U003098
FPE-8000-CRP cable set	F01U357892

8.4 Special Applications

8.4.1 Controlling Extinguishing Systems

The fire panel enables the activation of extinguishing systems via the extinguishing interface described in VDE 0833 Part 2 or by the VdS (standard interface SST in line with VdS Guideline 2496). Connection occurs either at the panel using the RMH 0002 A Relay Module for mains power or in the field via the FLM-420-RLE Interface Module.

For each panel, a maximum of 8 extinguishing panels can be activated in each case via an RMH 0002 A Relay Module for mains power. For each LSN loop, a maximum of 8 extinguishing systems can be activated in each case via an FLM-420-RLE Interface Module.

The requirement is for a maximum of one extinguishing area to fail in the case of a system fault. This means that from the second extinguishing area, there must be a redundant panel controller.

If several FLM-420-RLE Interface Modules are used to control the extinguishing system in each LSN loop, in addition to the redundant panel controller, the associated LSN 0300 A or LSN 1500 A module must also be duplicated.

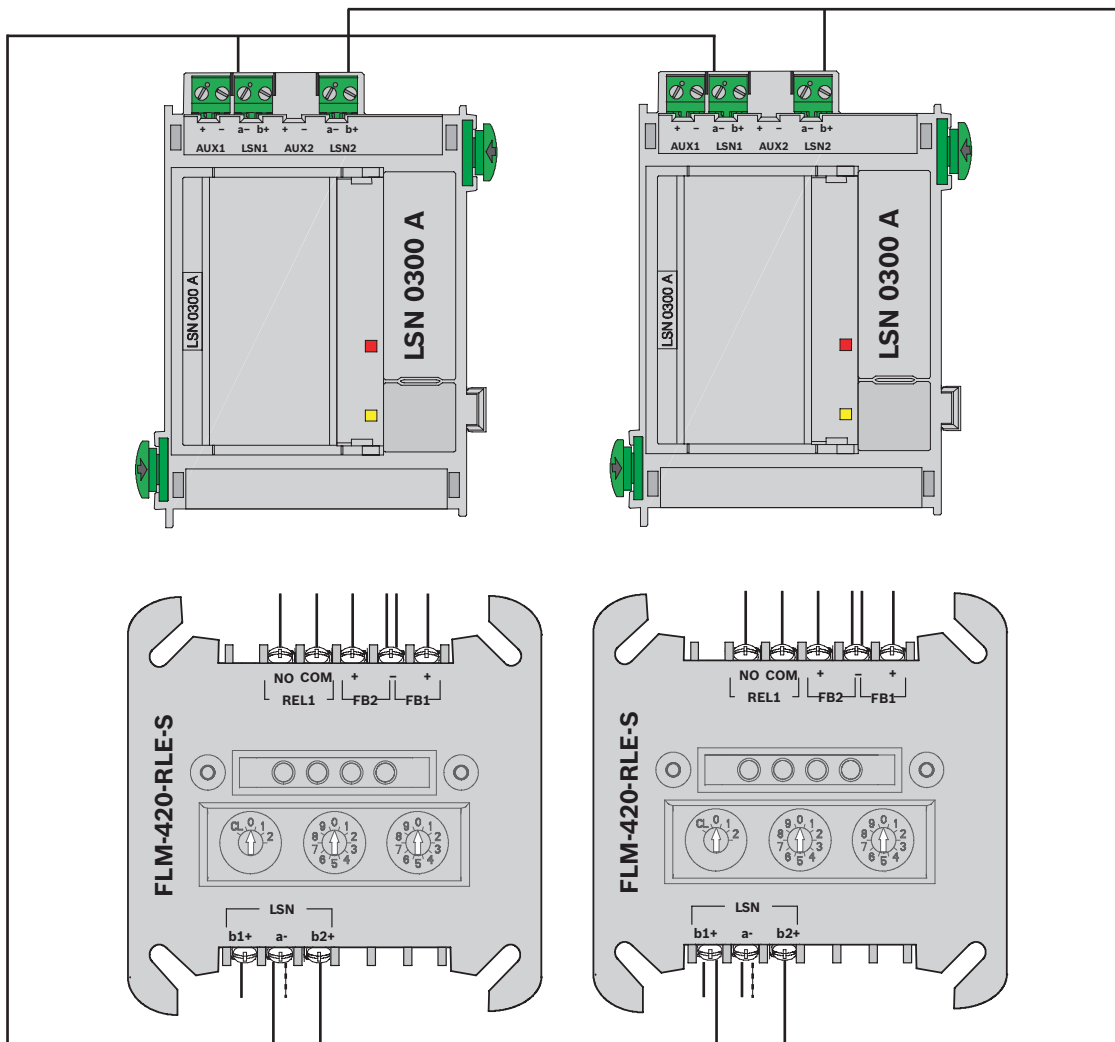

Figure 8.1: Several FLM-420-RLE modules in the LSN loop

Index

Numerics

4 Zone Conventional Module 28

A

Address Setting 30

Manual 30

Addressing 96

Automatic 30

Rotary switch 96

Alarm indication 14

AT 2000 Transmission System 120

AT3000 transmission unit 66

B

Batteries 103

Battery Controller Module BCM

Configuration example 44

BCM Battery Controller Module 43, 101

Plug load 46

Standby current 47

Bracket, power supply 70

Building Management System 7, 27, 48

C

Cable

Bushings 56

Cable length 36, 39

Cable sets 119

CAN interface 7

Commissioning 141

Quick guide 141

Communication 110

20 mA module 110

RS232 module 111

Components 157

Configuration

Example 7, 42

Contact rating 46

Conventional Interface Module 28

Conventional module 23, 106

CZM 0004 A 28

D

Detection point 28, 29

Detector 23

Automatic 24

Manual 25

DIP switches 96

Display 12, 14, 89

Disposal 143

Distributor rail 19, 68

Documentation 48, 141, 143

Door control 27

Dummy cover plate 119

E

Earth bar 70

EN 54-2, Requirements 156

EOL 28

Ethernet interface 7

Extinguishing systems, Activation 167

Extranet 28, 48, 143

F

Fire detector cable 28

Fire service

Connection 107

Devices 26

FLM-420/4-CON 28

Front doors 20, 22

FSP-5000-RPS Programming Software 7, 141

System requirements 149

Functional module 9, 100, 110

Accessories 118

Annunciator module 101

BCM Battery Controller Module 101

Conventional module 106

Interfaces 109

LSN 1500 mA 113

LSN 300 mA 112

Notification appliance zone module 115

Relay module 116, 117

Technical data 149, 150

Functional module: Communication 111

Functional module: Fire service interface 107

Functional module: Interfaces 108

Functional test 141

H

Height unit 64, 157, 162

Housing

frame installation 18

Installation 49

Installation dimensions 146

Installation instructions 50

Installation types 22

Scope of delivery 20

Versions 7

Wall mounting 21

Weight 146, 147

I			
Installation	47		
Documentation	48, 143		
Instructions	47		
MPC	93		
Quick guide	48		
Installation kit, 482.6 mm	20, 64, 157, 158, 162, 163		
Height unit	64, 157, 162		
Interface modules	26		
Interfaces	13		
Module	108		
Introduction	6		
J			
Junction board	66		
K			
Key deposit	26		
L			
Labeling strips	118		
Limits	36, 39, 144		
Local Security Network, LSN	31, 36, 38		
Cable length	36, 38		
LSN module	28, 112, 113		
M			
Maintenance and service	143		
Maximum limits	144		
Mounting frames	18		
Mounting plate	68		
Distributor rail	19, 68		
N			
Networking	7, 12, 14		
Networking guide	28		
Networking: Panel controller	91		
Notification appliance			
Audible	25		
visual	25		
Notification appliances	25		
O			
Overview	22		
P			
Panel controller	11, 13, 89, 148		
Elements	90		
Installation	89		
Networking	91		
Technical data	148		
Panel rail	19		
long	85		
short	83		
PAVIRO	7, 28, 144		
Periphery	23		
Planning	9, 28		
Instructions	28		
Software	9, 10, 11, 28		
Plena Voice Alarm System	7, 28		
Power loss	146		
Power supply			
External	121		
Power supply bracket	70		
frame installation housing	70		
Power supply unit	77		
Praesideo	7, 28, 144		
Product IDs	157		
R			
Redundancy	28, 29, 34		
Addressing	97		
Panel controller	34		
Remote keypad	16		
Addressing	139		
Functional elements	127		
Technical data	149		
Wiring	136		
Rotary switch	96		
Rotary switch number (RSN)	96		
S			
Safety Instructions	6		
Safety Systems Designer	9, 10, 11, 28		
Stickers	82		
System limits	36, 39, 144		
T			
Technical data			
Functional modules	149		
Panel controller	149		
Power loss	146		
Remote keypad	149		
System limits	144		
Temperature sensor	70, 78		
Test			
Addressing/activation	143		
Conventional/LSN functions	142		
Power supply	142		
Thermal printer	9, 122		
Changing the paper roll	125		
Jumpers	123		
Touch screen	15		
Transmission device	26		
Transmission unit	66		
Trouble Interface	121		

U

Universal security system 7

V

Voice alarm system 28, 144

W

Wiring guide 28, 48, 143



Bosch Sicherheitssysteme GmbH

Robert-Bosch-Ring 5
85630 Grasbrunn
Germany

www.boschsecurity.com

© Bosch Sicherheitssysteme GmbH, 2020